

# RADIO-CRAFT

HUGO GERNSBACK, Editor

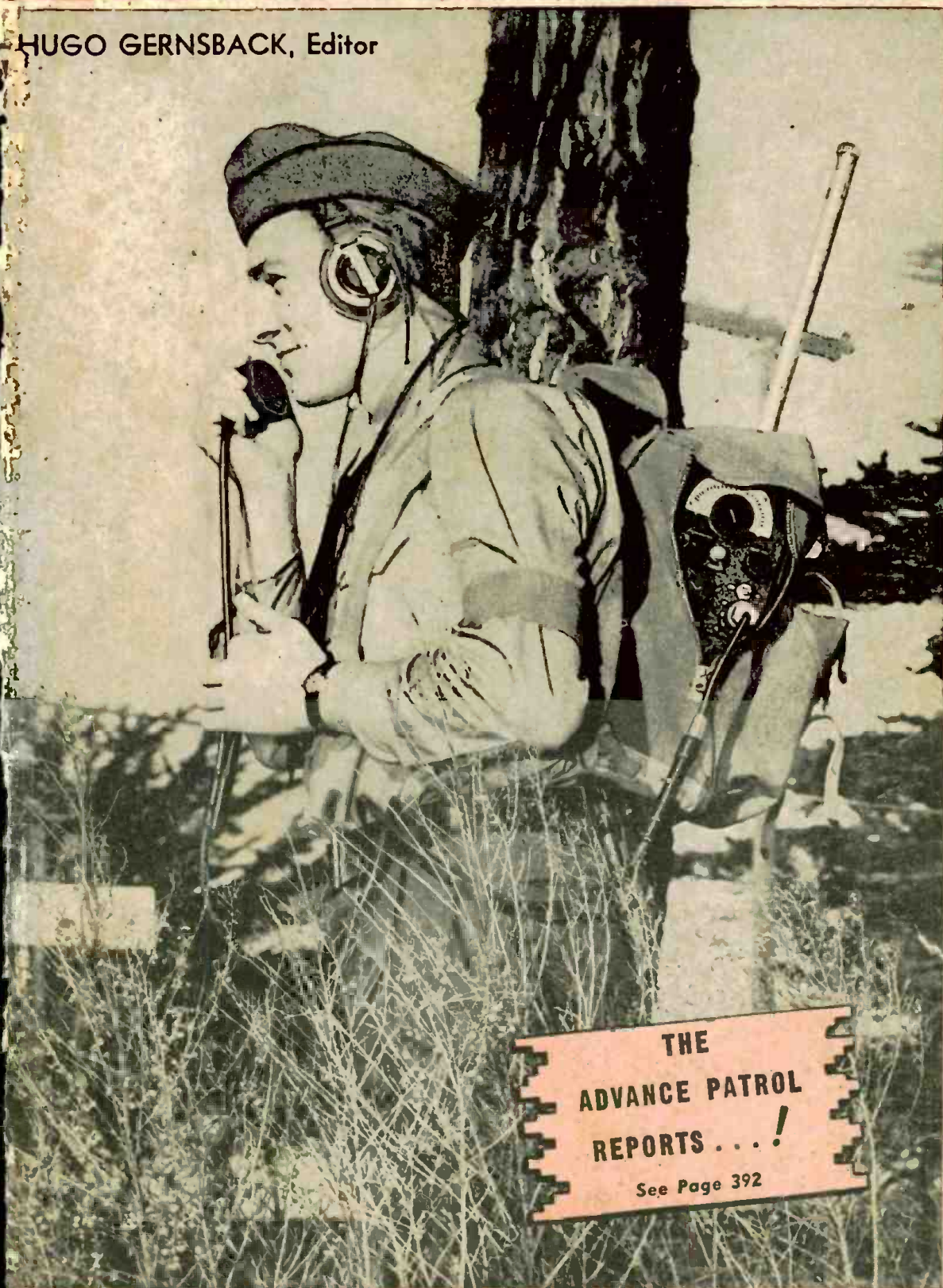

**THE  
ADVANCE PATROL  
REPORTS . . . !**  
See Page 392



**'CHUTE RADIO**

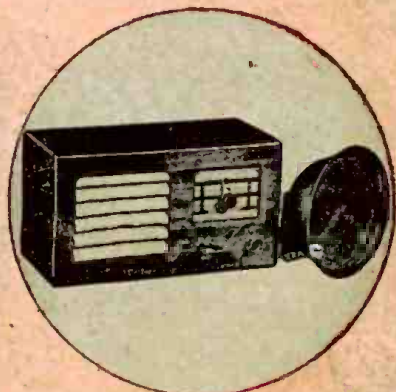

**RADIO-INTERPHONE!**

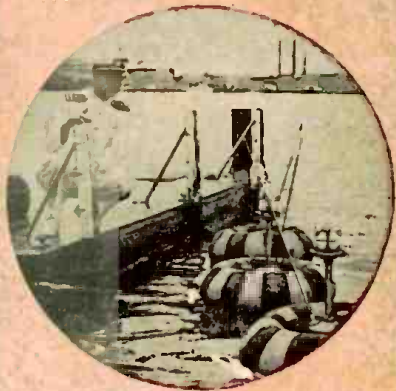

**RADIO LIGHTS**

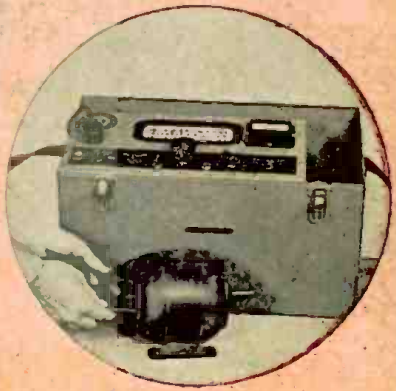

**LOCATING NOISE**

**JAN. RADIO'S GREATEST MAGAZINE**

**25c**  
CANADA 30c

**FM SERVICING POINTERS • DYNAMIC SERVICING WITH 'SCOPE  
VOLTAGE MULTIPLIERS • CONVERTING 2-V. SETS FOR 1.4-V**





# Radio Enlists for National Defense

**T**HE RADIO INDUSTRY has answered the call to national defense with an "all out" acceleration of creative activities. In research, in operation, in production—from blueprint to wavelength—the watchword is Service for the Needs of Uncle Sam!

For radio today has attained front-line rank in the national defense program. Its magic voice keeps our citizens informed, unites our nation as a vast community for free discussion. It links together the 21 republics of our hemisphere in bonds of friendship and mutual interest. It enables us to communicate around the world, to reach out to ships at sea, and to guide our aviators through fog and night.

### *Whole-hearted Response*

As a leader in radio research, as the only company that makes and does everything in radio, the Radio Corporation of America is proud of its call to duty. It eagerly enlists its facilities and personnel in the service of the American people.

The emergency finds RCA fully prepared. Months ago the "must" orders went to every subsidiary of the company, with the result that at the present

moment it is making daily contributions through its great laboratories, ceaselessly active in research—through its manufacturing company, in the production of radio apparatus—through communications, flashing message traffic around the earth—through radiomarine, in all-round communication service at sea—and through the National Broadcasting Company, in nationwide, world-wide broadcasting. To fill the need for men with technical skill, RCA Institutes is training radio operators.

### *Accepting the Challenge*

Using all the resources at its command, the Radio Corporation of America is meeting every demand for service—with expanded facilities, increased production, with smooth functioning speed.

In assuming its vital share in national defense, RCA realizes its opportunity to help preserve the unity and integrity of our national life. Each of its thousands of employees pledges his energies and enthusiasm to producing all needed equipment on schedule, to making America's radio communication system the most efficient on earth.



**RADIO CORPORATION OF AMERICA**

RADIO CITY • NEW YORK

RCA Manufacturing Co., Inc.  
National Broadcasting Company

Radiomarine Corporation of America  
R.C.A. Communications, Inc.

RCA Laboratories  
RCA Institutes, Inc.





*Is this what you want to know?*

# I will answer these questions for you—show you how to become a SUCCESS IN RADIO

If you know all the facts listed above—there is a real future for you as a Radio Technician. But if you do not—whether you've been in Radio for years or are just thinking of getting into this growing field—I can teach them to you at home nights in your spare time—train you to be a Radio Technician.

### Why Many Radio Technicians Make \$30, \$40, \$50 a Week

Relatively few persons can quickly locate and fix the troubles which arise in a modern, complicated home or auto Radio; few can operate or maintain broadcasting, aviation, commercial or experimental Radio stations, loud-speaker systems, commercial electronic devices or handle many of the other jobs which require a Radio Technician's specialized knowledge. That's why so many Radio Technicians enjoy good pay, steady jobs—why there are opportunities for Radio Technicians to hold other jobs and make good money—from \$5 to \$10 a week—in spare time.

### Many Make from \$5 to \$10 a Week in Spare Time While Learning

The N.R.I. Course teaches you the fundamentals of Radio and Television—gives you practical experience building circuits, making experiments with real Radio parts which are furnished. Also, it teaches you many practical Radio jobs that you can cash in on while learning. Many hold their regular jobs and make \$5 to \$10 a week extra in spare time fixing Radios while learning.

### You Get a Professional Servicing Instrument

The N.R.I. ALL-WAVE, ALL-PURPOSE Set Servicing Instrument makes practically any test you will be called upon to make in Radio service work, on both spare time and full time jobs. It can be used on the test bench, or carried along when out on calls. It measures A.C. and D.C. voltages and currents; tests resistances; has a multi-band oscillator for aligning any set, old or new.

### Find Out How We Teach Radio and Television

Act today. Mail coupon now for Sample Lesson and 64-page book. They're FREE. They point out Radio's spare time and full time opportunities and those coming in Television; tell how you can train at home nights in spare time to be a Radio Technician; show more than 100 letters from men successful in Radio who started this way. Mail coupon in an envelope or paste it on a penny postcard NOW.

### I TRAINED THESE MEN AND HUNDREDS MORE

#### Truck Driver Now Owns Business

Before taking the N.R.I. Course I was a truck driver making \$25 a week. Now I have my own Radio service shop and turn out up to \$800 of work a month. I recommend the N.R.I. Course. J. ALAN MOHR, 2047 Fillmore St., San Francisco, Calif.

#### \$10 to \$20 a Week in Spare Time

I repaired some Radio sets when I was on my tenth lesson. I really don't see how you can give so much for such a small amount of money. I made \$600 in a year and a half, and I have made an average of \$10 to \$20 a week—just spare time. JOHN JERRY, 1529 Arapahoe St., Denver, Colorado.

J. E. Smith, President  
National Radio Institute, Dept. 1AX  
Washington, D. C.

1. How to read diagrams and analyze them.
2. How to use test instruments.
3. How to get started in professional Radio.
4. Hints on how to run your service business profitably.
5. How to install P.A. equipment.
6. How to install intercommunicating systems.
7. How to figure charges.
8. What servicing instruments to buy.
9. How to locate parts in a chassis with and without service data.
10. How to know the cause of receiver trouble from observed effects.
11. How to make tests which isolate the defective stage and parts.
12. How to check for defects in a chassis.
13. How to align receivers without reference to service manuals.
14. How to appraise receiver performance from a circuit diagram.
15. How to plan your service bench and shop.
16. How to develop a time-saving servicing technique.
17. Short cuts in servicing midget universal receivers.
18. How modern electronic television receivers operate.
19. How to install and service television receivers.
20. How to practice servicing Radios to gain needed experience.
21. Practical demonstrations that show how basic Radio circuits operate.

*Sample Lesson*  
**FREE**

I want to send you a sample lesson, "Broadcast, All-Wave and Television Superheterodyne Receiver Principles." It covers the basic interferences in superhets and how they are rectified. It brings out the importance of the preselector, mixed first-detector, local oscillator, intermediate frequency I.F. amplifier, tracking, peak and band pass adjustments, band switching and modulation for adapting to television reception. All subjects covered with special emphasis on servicing. You can get this lesson FREE. Just mail the coupon.



**GOOD FOR BOTH** 64 PAGE BOOK **FREE** SAMPLE LESSON

J. E. Smith, President, Dept. 1AX  
National Radio Institute, Washington, D. C.

Mail me FREE, without obligation, Sample Lesson and 64-page book "Rich Rewards in Radio," which tells about Radio's opportunities and explains your 50-50 method of training men at home. (No salesman will call. Write plainly.)

I AM doing Radio work  I am NOT doing Radio work

Name ..... Age .....

Address .....

City ..... State ..... 23FR2



# RADIO-CRAFT

HUGO GERNSBACK, *Editor-in-Chief*

N. H. LESSEM  
*Associate Editor*

THOS. D. PENTZ  
*Art Director*

R. D. WASHBURNE, *Managing Editor*



## Contents JANUARY, 1941 Issue

VOLUME XII -- NUMBER 7

Mailbag .....	387
Editorial: Where Radio Fails.....Hugo Gernsback	391
The Radio Month in Review.....	392

### SERVICING

Visual Dynamic Servicing—Part I.....B. O. Burlingame	394
Britain's Wartime Radio Problems.....M. E. Southall	397
Relative Performance of Loop and Line Antenna Sets.....	398
Getting a Station on the Air.....	399
RADIO SERVICE DATA SHEETS:	
No. 298—General Electric Model JB-508 Phono-Radio Portable .....	400
No. 299—RCA Victor Model U-50 Radio-Phonograph (Chassis No. RC-414C) .....	409
Aligning Superheterodyne Receivers .....	401
Fluorescent Lighting—Latest Sideline for Servicemen.....	402
Converting 2-Volt Sets to 1.4 Volts.....Ken Moore, Jr.	407
New Circuits in Modern Radio Receivers—No. 40 .....	410

### F.M.

F.M. Servicing Pointers.....F. J. Gaffney	412
A New A.F.-Drift Correcting, Signal-Balancing, Direct-Coupled F.M. 24-Watt Audio Amplifier—Part II.....A. C. Shaney	414

### TEST INSTRUMENTS

How to Make a Modern Interference Locator.....Paul O'Connor	418
Recording Pointers.....	424

### SOUND

Sound Engineering—No. 13.....Conducted by A. C. Shaney	428
Why the Superheterodyne?.....Willard Moody	429
Voltage Multipliers and How They Work.....Steve Kusen	430
Build This High-Gain 3-Tube Phono Oscillator .....	434
.....L. M. Dezettel, W9SFW	

### RADIO DEVELOPMENTS

Radio Records "7-Mile" 'Chute Jump.....	436
'Phone Sound-Effects Machine.....F. G. Street, Jr.	436

### DEPARTMENTS, ETC.

Latest Radio Apparatus.....	439
Classified Radio Directory.....	441
Shop Notes—Kinks—Circuits.....	447
Books Reviews.....	448



Published by Radcraft Publications, Inc. Publication office: 29 Worthington Street, Springfield, Mass. Editorial and Advertising Offices: 20 Vesey Street, New York City, Chicago Advertising Office: RADIO-CRAFT, 520 North Michigan Avenue, Chicago, Ill.

RADIO-CRAFT is published monthly, on the first of the month preceding that of date; subscription price is \$2.50 per year in U. S. (In foreign countries, 75c additional per year to cover postage; Canada, 50c additional.) Entered at the post office at Springfield as second-class matter under the act of March 3, 1879.



#### Foreign Agents:

London—Gorrings's American News Agency, 9A Green St., Leicester Square, W. C. 2, England.  
 Paris—Messageries Dawson, 4 Rue Faubourg, Poissonniere, France.  
 Melbourne—McGill's Agency, 179 Elizabeth St., Australia.  
 Dunedin—James Johnston, Ltd., New Zealand.



Text and illustrations of this magazine are copyright and must not be reproduced without permission of the copyright owners.



Copyright 1941 Radcraft Publications, Inc.

**"DABLERS DELIGHT"—EXPERIMENTAL CIRCUITS**

Dear Editor:

I am the proud owner of a huge stack of *Radio-Craft* magazines.

These magazines have proved to be of unbelievable value for reference.

However, something is missing. *Radio-Craft* has published many articles on small 1- and 2-tube receiving sets.

Most radio dabblers (including myself) like to try a great deal of meaningless experiments to pass away the time.

For such, I believe that a great many fellow fans really need an article that deals with the construction and theory of building 1-tube regenerative gridleak detector sets.

These sets are very popular among dabblers and I believe that an article giving the dope for each of us (dabblers) to mathematically figure out his own set circuit with his own pet tube would be much appreciated.

Such an article should give a good basis for "starters" (including myself) and I know that *Radio-Craft* can do it and do a perfect job of it.

DOUGLAS MACDONALD,  
Milford, Maine.

P.S.—I have great need for a chart giving complete data on winding all sizes, including tube base, coil forms.

J. MacD.

*Radio-Craft* will be glad to publish occasional articles for "dabblers"—or any other group—if sufficient interest is shown by readers. However space in "*R.-C.*" is at a premium and unless a substantial proportion of our readers express interest in a given subject it would be unfair for us to use the space except for the type of articles for which the majority of the readers have expressed preference.

**ANOTHER VIEWPOINT**

Dear Editor:

I have been a newsstand reader of *RADIO & TELEVISION* for years, and last month was "talked in" to add *Radio-Craft* to my list of radio mags for monthly consumption.

I thoroughly enjoyed this magazine and in particular the article by H. S. Manney, on the ABC of Db., Vu, Mu, etc. I hope you will grant the discussion of further formulae by the author as I cleared up several puzzling points by studying his article.

In my humble opinion *Radio-Craft* is to the Serviceman what *Electronics* is to the engineer. Best 73.

PETER HURGEN,  
Bronx, N. Y.

Thanks for the bouquets. How about taking part in the preparation of *Radio-Craft*? Send us articles, Kinks, Useful Circuits, Operating Notes, etc. *Radio-Craft* is your magazine. Help keep it that way. Incidentally—we pay for all such published contributions.

**"HAM" INTERFERENCE ON BROADCAST BAND**

Dear Editor:

Having been asked by Servicemen at various times, why amateur transmitters are received on broadcast receivers, I suggested the enclosed tables of frequencies to determine the cause.

I realize the information they contain is not original but do not remember seeing them in the form presented here.

\*Reproduced on following page.

**SAVE with Meissner**

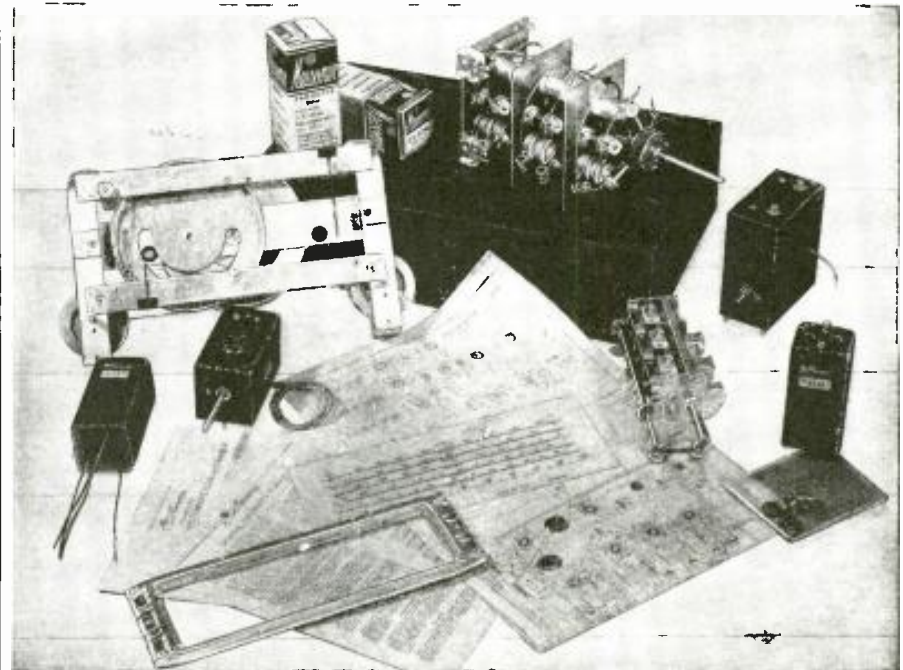

**ESSENTIAL KITS**

**Latest innovation gives you highest quality in home-built radio at lowest possible cost!**

**SAVE TIME**—No need to fuss around with experimental designs; Meissner Kits are fully engineered and supplied with complete instructions and detailed Schematic and Pictorial Wiring Diagrams.

**SAVE MATERIALS**—Use up a lot of spare parts now lying around useless; odds and ends of condensers, resistors, sockets, hook-up wire, etc. are all that are required to make a complete receiver out of one of these Kits!

**SAVE MONEY**—Not only by using up parts that are on hand but by buying the Essential Kit you get these "special" parts at a material saving over the regular Catalog Price.

**Wide Variety of Designs to Fit Any Need!**

With the continued success of Meissner Complete Kits assured by ever-increasing sales, Meissner now offers a means of building one of these fine, fully engineered receivers at even lower cost—by using these new Essential Kits! They contain all of the special Meissner parts such as coils, tuning condenser, dial, I-F transformers, punched chassis, etc. with detailed wiring instructions, same as furnished with the Complete Kit. A complete Parts List is also furnished so that the remaining small parts may be readily obtained from your regular Parts Jobber. Many of these parts, however, will probably be found in your own shop! All of the major designs in the Meissner Kit line are now available in this form, from the 14-tube Traffic-Master down to the 6-tube sets.

**Write for Your Free Copy of the New Meissner General Catalog!**

ADDRESS DEPT. G-1







# RADIO made EASY

LEARN AT HOME IN SPARE TIME!

36 Volumes in 1 Big Book!

1. Broadcasting System
2. Sound, Speech, Music
3. Electron Theory: Electric Current
4. Elec. Units: Ohm's Law, Circuit's Batteries
5. Elec. Circuits: Batteries
6. Magnetism
7. Electromagnetism
8. Electromagnetic Induction
9. Inductance
10. Capacitance: Condensers
11. A.C. Circuits
12. Filters
13. Measuring Instruments
14. Radio Waves
15. Broadcasting
16. Receiving
17. Vacuum Tube Principles
18. V. T. Characteristics
19. Vacuum Tube Construction
20. V. T. Detector and Amplifier Action
21. Radio Frequency Amplification
22. "Superhets"
23. R.F. Amplifiers; Tuning Coils
24. Audio Amplifiers
25. Loudspeakers
26. Battery Receivers
27. Power-Supply Units
28. Elec. Receivers
29. Auto and Aircraft Radio
30. Photo Pick-ups; Sound Systems
31. Short-Waves
32. Photoelectric Cells; Cathode-Ray
33. Television
34. Antennas and Grounds
35. Testing: Servicing
36. Sound Pictures

**Use it 5 Days —OUR RISK!**  
Your money back if not fully satisfied. Don't delay—start now—mail this coupon at once!

972 Pages  
508 Illus.

**\$4**

Only **\$4**

**RUSH COUPON TODAY!**  
Radio & Tech. Publ. Co. Dept. RC-11, 45 Astor Pl., N. Y.

Enclosed find \$4. (\$4.50 foreign) for my copy of "RADIO PHYSICS COURSE" with your 5% Money-Back Guarantee.

Name \_\_\_\_\_  
Address \_\_\_\_\_  
City \_\_\_\_\_ State \_\_\_\_\_  
 Send me free circular.

## Radio as a Career

By JULIUS L. HORNUNG

Tells everything one needs to know about getting into every field of radio work—servicing, engineering, ship operator and studio broadcasting. Full details and helpful advice on training, salaries, advancement. Only \$1.50. Sent postpaid. Satisfaction guaranteed by

**Funk & Wagnalls Company**  
Dept. 132.  
354 FOURTH AVENUE, NEW YORK

## RADIO TECHNOLOGY



RCA Institutes offer an intensive course of high standard embracing all phases of Radio and Television. Practical training with modern equipment at New York and Chicago schools. Also specialized courses in Aviation Communications, Radio Servicing and Commercial Operating. Catalog Dept. RC-41

**RCA INSTITUTES, Inc.**  
A Radio Corporation of America Service  
75 Varick St., New York. 1154 Merchandise Mart, Chicago

## RADIO-TELEVISION

Oldest, largest Radio-Television school in West trains you for good pay job. Complete instruction including Radio Construction and Service, Broadcast Operating, Sound, Talking Pictures, Television, Public Address, etc. Flexible Plan to meet specific needs of those with or without jobs. Transportation allowed to L.A. Earn room and board while learning. Request Free Catalog.

**NATIONAL SCHOOLS** Dept. RC-1  
Los Angeles

## Are You The Man For The Job?

ARE YOU prepared to step into the better radio jobs that are open to men with advanced training? CREI home-study training is the PROVEN WAY to earn more money in radio. 5,000 radio-men can't be wrong—so, find out NOW how we can help you get ahead. WRITE FOR FREE ILLUSTRATED BOOKLET, CAPITOL RADIO ENGINEERING INSTITUTE, Dept. RC-1, 3224-16th St., N.W., Washington, D. C.

**Group No. 1.**—Transmitter is received by the receiver oscillator beating with the transmitter frequency and producing an I.F. of 460 kc.

**Group No. 2.**—Transmitter is received by the 2nd-harmonic of the receiver oscillator beating with the transmitter and producing a beat of 460 kc., the I.F. of the receiver.

**Group No. 3.**—Transmitter is received by the 2nd-harmonic of the oscillator beating with the transmitter frequency and producing a beat of 460 kc., the I.F. of the receiver. The usual trap circuits are of course used to eliminate the transmitter frequency.

**GROUP NO. 1—160-METER PHONE**  
All I.F.'s—460 kc.

TRANS. FREQ. IN Kc.	RECEIVER	RECEIVER OSC.
1,800	880 Kc.	1,340 Kc.
10	90	50
20	900	60
30	10	70
40	20	80
50	30	90
60	40	1,400
70	50	10
80	60	20
90	70	30
1,900	80	40
10	90	50
20	1,000	60
30	10	70
40	20	80
50	30	90
60	40	1,500
70	50	10
80	60	20
90	70	30
2,000	80	40

**GROUP NO. 2—160-METER PHONE BAND**  
2nd-Harmonic of Receiver Beats with Transmitter

Beat difference of 460 Kc. All I.F.'s—460 Kc.

TRANS. FREQ. IN Kc.	REC.	REC. OSC.	REC. OSC.	2ND-HARMONIC
1,800	670 Kc.	1,130 Kc.	2,260 Kc.	
10	75	35	70	
20	80	40	80	
30	85	45	90	
40	90	50	2,300	
50	95	55	10	
60	700	60	20	
70	05	65	30	
80	10	70	40	
90	15	75	50	
1,900	20	80	60	
10	25	85	70	
20	30	90	80	
30	35	95	90	
40	40	1,200	2,400	
50	45	05	10	
60	50	10	20	
70	55	15	30	
80	60	20	40	
90	65	25	50	
2,000	70	30	60	

**GROUP NO. 3—80-METER PHONE**  
All I.F.'s—460 Kc.

TRANS. FREQ. IN Kc.	REC.	REC. OSC.	2ND-HARMONIC	REC. OSC.
3,900	1,260 Kc.	1,720 Kc.	3,440 Kc.	
10	65	25	50	
20	70	30	60	
30	75	35	70	
40	80	40	80	
50	85	45	90	
60	90	50	3,500	
70	95	55	10	
80	1,300	60	20	
90	05	65	30	
4,000	10	70	40	

HARRY E. WESSEL,  
West Radio Service,  
Baltimore, Md.

**A BUSINESS-GETTING BUSINESS CARD**

\*Enclosed please find sample of my calling card—a genuine business getter. I think every radio Serviceman should have a similar card—good business.

MICHAEL PLATKO, JR.,  
Toronto, Ohio

\*Reproduced below.

**WANTS MORE OF THE SAME**

Dear Editor:  
I wholeheartedly agree with Mr. Moody in the Nov. "Mailbag."

How about some more dope on regulated power supplies—something with some specifications (core and wire sizes, and such) to be guided by?

Yours for more and better "R.-C.'s," and more articles by Messrs. Shaney and Sprayberry.

JEROME GUGGENO,  
Birchwood, Wis.

**RADIO-CRAFT VS. THOS. F. SHAMBACH, JR.**

Dear Editor:  
In reading my Sept. issue of *Radio-Craft* I was amused by one illustration which I think should be called to your attention.

On page 136 Mr. C. F. Kettering is shown seated before a Telly Camera holding a French Phone in his LEFT hand. According to your caption, Mr. Kettering's image is picked up by the spot on the Front Cover. Horrors!—you will now notice that Mr. Kettering is somewhat of a magician, for in this cover photo he is facing in the opposite direction and holding the Phone in his RIGHT hand. Now at first I thought it was the terrific heat wave we have been having here, but I am now convinced that my eyes have not deceived me, and as I am not under the influence of alcoholic beverages, may I suggest that someone please replace the

## RADIO SERVICEMAN

Shop Now Located

--at--



MIKE PLATKO, Jr.

The business-getting business card of Mike Platko, Jr. Why not have some handy data for the radio listener printed on the back? For example the call letters, frequencies and wavelengths of the major stations received best in a given locality.

defective camera or receiving tube or perhaps straighten the KINK in the coaxial cable, as those wires might be crossed.

THOS. F. SHAMBAK, JR.,  
Middleburg, Pa.

We object (Hi!)! Anyway, Mr. Kettering may have tired of holding the Phone in one hand, in the interim of taking the 2 photographs, and may have switched-over to the other hand. A French Phone is, we believe, usable in either hand. How about it, Junior?

"MR. MONROE M. FREEDMAN  
c/o RADIO-CRAFT"

Dear Sir:

I am writing you in regard to your Signal Tracer, a circuit of which appeared in the Sept., 1940, issue of *Radio-Craft*.

I have constructed this Signal Tracer, but I don't seem to get the results I should. I cannot get the tuning eye to close by touching the escillator grid with the test probe.

The test probe cable is, as you recommended, a coaxial cable, but I am not getting the proper results from the high-frequency buzzer by touching the test probe to the antenna or the R.F. stages. The buzzer signal goes through the set under test OK, up to the loudspeaker, but I cannot get the buzzer signal through the speaker (on the set under test).

I would appreciate it very much if you could give me a few pointers on where my trouble may be.

JOHN H. MORRIS,  
Raceland, Ky.

We pass on to *Radio-Craft* readers the following reply, from Mr. Freedman, which was sent to Mr. Morris.

In all probability the 6E5 is wired incorrectly. To check may I suggest you set the Selector Switch to the No. 4 or A.V.C. position. In this position your 6E5 grid is connected directly to the test probe. Apply the probe along the A.V.C. circuit in the receiver, then tune variable condenser and note the action of the 6E5. If it acts satisfactorily, as a tuning indicator should, it is wired OK and will work properly; if not, it is wired incorrectly. I would suggest you check the connection between the control-grid of the 6E5 and the detector load resistor.

With reference to the high-frequency buzzer, apply its output at plates and grids of tubes (working back from speaker to antenna). Is a condenser in series with the output from the buzzer? Is the buzzer wired up properly? Has the buzzer enough output to send a signal through the output transformer and into the speaker? A buzzer with sufficient output can be heard with ease.

**BOUQUET—NEW ZEALAND  
STYLE**

Dear Editor:

I wish to congratulate you on your new streamlined issues. I wish other mags would take a hint from your mag. I have read with much care A. C. Shaney on "Power Amplifier Load Matching," and H. S. Manney on "Speaker Matching Technique."

I congratulate Chas. R. Leutz ("Serving Orphans and Private Brand Sets"). We have a good many private brands here to meet and manufacturers won't send a diagram of sets. I like to know when new types of valves (tubes) will stop. Some



**IT'S TIME you learned about this  
"Success Combination"**

WITH THESE 2 INDISPENSABLE Ghirardi BOOKS  
YOUR RADIO SERVICE WORK IS MADE Easy

**1. THEORY**

**MODERN RADIO Servicing**  
Here your practical training for radio service work complete in this 148-page 1200-page Ghirardi home-study course.

**WHAT TO DO—HOW TO DO IT**  
It teaches you everything you need to know about modern testing and repairing—all the basic theory, all the practical short-cut shop methods. A big 420-page section explains all types of servicing test instruments—how they work, how constructed, how to build them, how to use them. Another fat section on trouble-shooting and repairing—with newest short-cuts for tracking down all types of receiver troubles.

**LEARN HOW TO REPAIR  
RADIOS EXPERTLY**

You'll get 184 pages describing advanced "Factory Methods" for Super-het Alignment; Interference Elimination; Repairing all sets, etc.; with another 427 pages on Auto-Radio Servicing and Installation; Servicing All-Wave Sets and High-Fidelity Sets; AVC and QVC Circuits; Selling and Advertising; and other special problems. All the essentials of present-day radio servicing work are condensed here in 1 convenient source-book—40 Give you the solid background you have to have today and to bring your servicing methods, right up to the minute. A "must" book for every wide-awake service man! 1200 pages, 708 illus., 720 review questions. 766 topics. \$4.

**2. PRACTICAL JOB DATA**

**RADIO Trouble-Shooter's HANDBOOK**

If you are a serviceman, stop costly time-wasting... speed up your service work with Ghirardi's big data manual—the greatest servicing shop aid on the market.

**Tabulated Data Speeds Service Work**  
Here—at a flash—you get practical job data for every-day job use. No more guesswork! No more tip-flees! It's all here—ready for handy, instant reference. The only book of its kind! You get:

**3,313 CASE HISTORIES**  
The Greatest collection of serv-

icemen's case histories in the world—trouble symptoms and remedies for 3,313 common receivers. Then 1-7 Points—over 15,000 listings. For auto radio you get quick-use data on installations, ignition systems, interference elimination, wiring, etc. Plenty of other data, too—Trouble-Shooting Charts; Servicing Inter-communicators and Sound Recorders; RMA Codes; Trade Directories; Wire, Tube, Resistor and Condenser Charts; etc. What a load of data for the price! You can't get along without it! 518 pages, 124 illus., 8 1/2" x 11" size (8 1/2" x 11"), FabriKoid-bound. \$3.



TRY THEM 5 DAYS  
-AT MY RISK!

**RUSH  
COUPON  
TODAY!**

**RADIO & TECHNICAL PUBL. CO.,**  
Dept. RC-11, 45 Astor Pl., New York

Enclosed find payment for:  
 MODERN RADIO SERVICING  
 RADIO TROUBLE-SHOOTER'S HANDBOOK  
 BOTH BOOKS at \$6.50 Special Money-Saving Combination Price.

NAME .....  
ADDRESS .....  
CITY ..... STATE .....  
 Please send FREE circulars.

are worthwhile but others duplicate other types.

Congrats to your mags and "73"

L. A. PEEVERS,  
Otekaike,  
Sect. 8, K.R.B.  
Iamani, New Zealand.

Thank you, Mr. ("Away Down Under") Peevers, for your kind remarks. We note from your letterhead that you're a member of the N. Z. Radio Hobbies Club. Maybe some of our hobbyists elsewhere throughout the world would like to swap experiences with you and the members of your club. We'll be glad to forward correspondence.

**SASK. TO SASK. VIA "R.-C."**

Dear Editor:

I, too, agree with Mr. A. Clayson of Verlo, Sask. (June *Radio-Craft*, pg. 707). There is no A.C. here, not even in my town. I have often wondered what the percentage of battery radio receivers was to electric. By the way the battery "radios" and battery-operated testers are dealt with in the magazines, would indicate that there are mighty few, yet I think there must at least be many battery-operated radio sets, although most of the Servicemen would have access to electric lines.

Another thing, I do not care for your Xmitter articles. I think that the ham and Serviceman are two distinct classes and should have individual magazines.

EMIL EPP,  
Box 40, Canot River, Sask.

**HIGH-POWER P.A. SYSTEM!**

Police Commissioner Valentine of New York City rightly guessed a Communist rally in Union Sq. would not draw the expected crowd of 15,000 to 20,000 persons, and hence, would not need a loudspeaker system. So what happened? So 4 orators spoke simultaneously from the platform to 4 different sections of the crowd of 5,000!

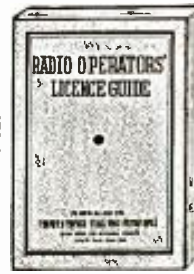

**RADIO OPERATORS'  
LICENSE GUIDE**

SECOND EDITION  
Containing over twelve hundred and fifty acceptable answers to the new "Six Element" radio operator license examination questions as embodied in the Federal Communications Commission Study Guide.

**YOU NEED THIS GUIDE  
TO PASS  
YOUR EXAMINATION**

\$3.00 Postpaid, refunded if not satisfactory.

Wayne Miller, Suite 200  
Engineering Building  
Chicago, Illinois



**Be a RADIO SERVICE EXPERT  
LEARN AT HOME IN SPARE TIME**

Clear, simple, fascinating lessons—practical work with experimental kits—make training easy and fast. Up to date R.T.A. methods, under personal guidance of prominent engineer and educator, highly endorsed by leaders in radio industry. Spare-time profits soon pay for training.

**START NOW**—have your own business or fit yourself for well paid work with radio dealers, in factories, police, marine or television fields. **DON'T DELAY!** Send **AT ONCE** for complete information and **BOOK FREE!**

**RADIO TRAINING ASS'N. OF AMERICA**  
1559 Devon Ave. Dept. RC-11 Chicago, Ill.

**RADIO COURSES**  
Mid-Term Classes Now Starting  
RADIO OPERATING—BROADCASTING  
RADIO SERVICING—a practical course  
RADIO AMATEUR CODE ● TELEVISION  
ELECTRONICS—1 yr. day course 2 yrs. eve. Day and Evening Classes. Booklet Upon Request.  
**New York Y.M.C.A. Schools**  
4 W. 64th Street New York City

Correspondence Courses in  
**RADIO and ELECTRICAL ENGINEERING**  
**ELECTRICAL ENGINEERING** Get good grasp of wide electrical field. Prepare yourself at Low Cost for secure future. Modern, simplified. You can understand quickly.  
**RADIO ENGINEERING** Extra fine course in radio, publication address, etc. for secure future.  
Trains you to be super-service man, real vacuum tube technician. Expert kits furnished. Diploma on completion.  
Tuition, \$25. either course. Deferred payment plan.  
**FREE** Get copies of school catalogs, student magazines, complete details. **SEND NOW!**  
**LINCOLN ENGINEERING SCHOOL, Box 931-C25, LINCOLN, NEBR.**



Order your copy NOW—the only  
**P. A. HANDBOOK**

1st Edition  
 Almost Gone!  
**ORDER TODAY**

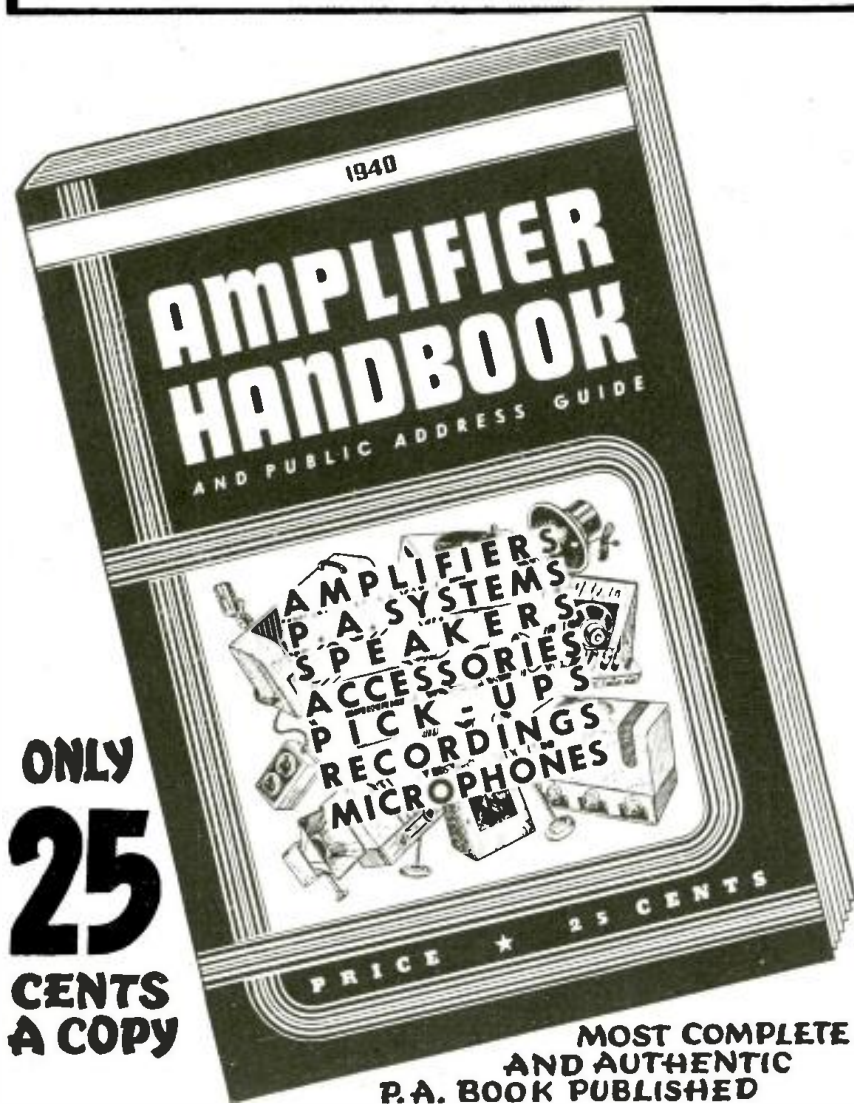

ONLY  
**25**  
 CENTS  
 A COPY

**MOST COMPLETE  
 AND AUTHENTIC  
 P. A. BOOK PUBLISHED**

THAT no book has yet been published which covers amplifiers and sound systems (also kindred systems), in one complete, authentic volume is almost unbelievable. Yet, it is a fact, there is no book in print which covers Public Address from A to Z. To bridge this wide-spread gap, RADIO-CRAFT will publish a complete, magnificent volume on Public Address of such magnitude—so complete and authoritative—that every man engaged in radio can have both a theoretical and practical knowledge of the function and operation of sound systems. The complete with illustrations that the volume fully justifies its title of 1940 AMPLIFIER HANDBOOK AND PUBLIC ADDRESS GUIDE. This great HANDBOOK on Public Address should be read and studied by those who consistently build, service and sell sound equipment.

**A MATCHLESS VOLUME**  
 As complete as you would expect to find any engineering handbook—this is how the radio or P. A. man finds the AMPLIFIER HANDBOOK AND PUBLIC ADDRESS GUIDE. With essential technical data compiled from an exceptionally large number of sources, the volume covers nearly a hundred different subjects coordinating every conceivable branch or sub-division of Public Address.

**THE CONTENTS**  
 To actually show the scope and magnitude of the AMPLIFIER HANDBOOK AND PUBLIC ADDRESS GUIDE, an analysis of the contents is found at the right, showing the breakdown of the material featured within each particular section. A thorough reading of the contents shows the completeness of this book.

**A Resume of the Contents of the  
 AMPLIFIER HANDBOOK  
 AND PUBLIC ADDRESS GUIDE**

**FOREWORD**

**INTRODUCTION**

Definitions—decibels, frequency, input, output, impedance, etc.

**SECTION I—SOURCE**

- Carbon microphones (single-button and double-button)
- Condenser microphones
- Velocity (ribbon) microphones
- Dynamic microphones
- Crystal microphones (sound-cell types, crystal diaphragm types)
- Cardioid microphones
- Contact microphones
- Phonograph pickups (magnetic types, crystal types)

**SECTION II—AMPLIFIERS**

- Voltage Amplification**
  - Design of resistance-coupled voltage amplifiers
  - Commercial voltage amplifier
- The Power Stage**
  - Class A amplifiers
  - Class AB amplifiers
  - Class AB<sub>2</sub> amplifiers
  - Class AB<sub>3</sub> amplifiers
  - Class B amplifiers
  - When to apply class A, AB, and B amplification
- Power Supplies**
  - Half-wave rectification
  - Full-wave rectification
  - Voltage doublers
- Filter Circuits**
  - Power supply regulation, etc.
- Practical Hints on Amplifier Construction**
  - Microphonism
  - Placement of components
  - Tone compensation
  - Inverse feedback
  - Remote control methods

**SECTION III—DISTRIBUTION**

- The Loudspeaker**
  - Dynamic speakers
  - Speaker performance (frequency response, efficiency)
  - High-fidelity speakers
- Speaker Baffles and Housings**
  - Outdoor speaker installations
  - Power cone speakers
  - Radial (360° distribution) speaker baffles

**SECTION IV—COORDINATION**

- Input impedance matching
- Matching speakers to P.A. installations
- Phasing speakers
- Effect of mismatching speakers to amplifier output
- A typical P.A. installation (in a skating rink)

**SECTION V—USEFUL PUBLIC ADDRESS DATA AND INFORMATION**

- Speaker matching technique
- The ABC of Db., VU, Mu, Gm and Sm
- Charts and formulas useful to the practical P.A. sound man
- Handy index to important articles on public address and sound

**RADCRAFT PUBLICATIONS ■ 20 VESEY STREET ■ NEW YORK, N. Y.**

RADCRAFT PUBLICATIONS, INC. ★ 20 VESEY STREET ★ NEW YORK, N. Y. RC-141  
 Gentlemen: Enclosed find my remittance of 25c for which send me POSTPAID, one copy of your NEW—  
 1940 AMPLIFIER HANDBOOK AND PUBLIC ADDRESS GUIDE.

Send me ..... others, for friends, also POSTPAID @ 25c each.

Name ..... Address .....

City ..... State .....

Remit by check or money order; register letter if you send cash or unused U.S. Postage Stamps.

**Order Your Copy NOW—**

*Clip Coupon and  
 Mail Today!*



# RADIO-CRAFT

"RADIO'S GREATEST MAGAZINE"

## WHERE RADIO FAILS

By the Editor — HUGO GERNSBACK

... printed radio programs,  
distributed free, could be  
a profitable enterprise

**W**HEN the telephone first started out, it was not the huge universal necessity that it is today. When you wanted to call up a friend in those early days, you just told the Operator that you wanted to talk to Dick Jones on Main Street and the connection was made in due time. It took several years before such a thing as a printed telephone directory was even thought of and more years till a regular telephone directory was printed and distributed free to subscribers.

Possibly the telephone companies even today could get along without phone books, because you can always get a subscriber through the medium of "Information." But, inasmuch as the continuous use of "Information" would tax the telephone lines unduly and make for handicaps for the public, the telephone directory no doubt is more than a convenience today. The telephone companies found that in the long run the huge expense of printing their directories saved money.

In radio, we have a somewhat analogous condition in that the radio broadcasters disseminate a large variety of programs which can be received through the medium of a radio receiver. Yet, the well-known visitor from Mars would no doubt scratch his head thoughtfully on his first visit to Earth when he noted the obstacles that are put in the way of a listener to find out what programs there are on the air and when they are about to begin or end.

The visitor from Mars would reason that inasmuch as it was profitable for the telephone companies to supply free directories to their subscribers, that, no doubt, the combined radio interests—represented on the one side by the radio broadcasters, and on the other side by the radio set manufacturers—would find it equally profitable to supply listeners with daily or weekly programs.

Nothing like this, of course, is done at the present time and we behold Radio Broadcast, long out of its swaddling clothes and grown to young manhood, in a position where the public is kept much in the dark as to radio programs.

You will say that radio programs are printed in the daily press. This, however, is true only in a measure. The daily press today considers radio as a formidable competitor and is not well inclined to give radio free program publicity. So, whatever programs are printed, are printed grudgingly, usually in skeleton form, and practically never (with few exceptions) is the real intent of the program given. Worse than this, as a rule, only the larger stations are featured. The *New York Sunday Tribune*, for instance, lists only 4 stations! There are few newspapers giving the full program listings, particularly when there is any commercial tie-up with a particular program. Yes, there are a number of program weeklies, which, however, you must buy. In the case of the weeklies a large part of the program usually is inaccurate, due to last-minute changes for any number of reasons, such as cancellations of programs due to special events and many other reasons.

It might be countered that the radio broadcasters themselves announce the daily program over their own station. They do so (if at all), at certain hours of the day when possibly most people are not listening. It would be impractical for the station to announce the program for the rest of the day every half-hour as it would be too time consuming.

That is, however, only one part of the story because there are such things as radio habits of the populace. It is surprising for instance, to find how many people in this country turn on their radio set day after day without ever going to the trouble to tune-in a different station. While the younger people are more radio program conscious, the older people who have less time to spare, very frequently "stay with one station." They have become used to certain programs at certain hours of the day and by force of habit seldom, if ever, change to another station. And inasmuch as one station naturally does not announce the program for another station and as most people do not consult the poor programs printed in newspapers unless for special events, it so happens that a truly tremendous percentage of radio listeners are totally ignorant of many good programs that are on the air day in and day out. If you do not believe this, write down a dozen different good programs which are features on the various stations and ask your friends how many of these they listen to. You will be astonished at the result.

You might wonder, with our friend from Mars, why, if all this is true, that the radio stations and the radio set manufacturers

have not gotten together and supplied free printed radio programs every day, or twice a week. And it *would* be necessary to issue a program this frequently if it is to have any value at all.

As for ourselves, we were never fully convinced that supplying free printed programs to radio set owners was ruinous because advertisers could, and would, be glad to share the cost of distribution if a good printed program was supplied radio listeners. Advertisers now bear the huge burden of a sponsored radio program and the chances are that these advertisers—or others—could no doubt be found, to sponsor the printed radio program in one form or other, as well.

What stands in the way probably is the fact that it has been found most difficult to provide a handy type of program. The printed flat page is not the ideal way for program presentation. It is difficult to read; often bewildering, and about as much fun as reading a dictionary. We can, however, imagine different specialized gadgets which could be attached to a radio receiver making the reading of the radio program not only easy, but enjoyable. Without devoting many days of thought to the subject, we can immediately think of several forms of program presentation. The simplest way would be a program printed on a long strip of paper. This is placed in a holder and by means of a knob you rotate a drum; then in an opening you will get the time of the day and the program from the different stations. If you wish to go fancy, you can illuminate the program from the rear, or from the front. There are a number of variations of this idea which can easily be engineered into a compact appliance, always provided somebody will supply the physical printed roll or strip of paper on which the program is printed. Then, when Tom Jones suddenly decides that he wishes to listen to the latest news report, he does not have to wade through a number of newspapers to see on which station is the news program and at what time, only to find out in the end that some station has a commercial news program which the newspaper did not list at all, and which Jones accidentally discovers by fiddling with his tuning dial.

I maintain that it would pay someone in conjunction with radio broadcasters and radio set manufacturers to supply radio listeners with such printed physical programs and I also believe that it could be made to pay, just as radio advertisers today find that it pays them to advertise over the air. It all depends on *how it is done*. Just pure advertising on the printed program would, of course, not do. Something much better and more dramatic must be thought up. Cut-outs for the children, coupons, special educational pictures for the young element and a host of other ideas could be tried out, successfully in conjunction with a printed program of this type. If the presentation is right, if the material is right, such advertising can be made to pay for itself.

There remains the printed program supplied directly by radio through the radio station facilities and the radio set itself.

While it may be some years before this dream is realized, we are getting closer to it all the time. Facsimile radio is, of course, the answer to this. Even today there are in this country approximately 16 stations which supply facsimile radio as well as radio programs over the air every day. In due time, when radio set manufacturers finally wake up and see the light, the final word about radio programs will be written. It will, however, be necessary for some budding genius to provide a very low-cost facsimile unit that can be built for \$1 or \$2, or less, into every radio set. Each set will then have a similar gadget to the one I described above and the broadcasters themselves will print the program over your radio set while you are asleep. The program will be printed in the early morning hours right on a paper roll giving you the day's program of *all* the stations. By that time, of course, the various radio stations will have arranged matters in such a manner that a *united radio program* will be sent over the air every night and in this program all stations will be represented. If now some clock manufacturer will get up a cheap movement, the program roll of paper can then be rotated automatically so that at any time during the day you can glance at your radio set and find the correct printed program at the right time and for the next few hours, exposed to your view. This will be the ultimate, in the sane dissemination of radio programs.

A fantastic pipe dream? Not at all! It can be done even today and I know it will be done in the not-too-distant future.

The "radio news" paper for busy radio men. An illustrated digest of the important happenings of the month in every branch of the radio field.

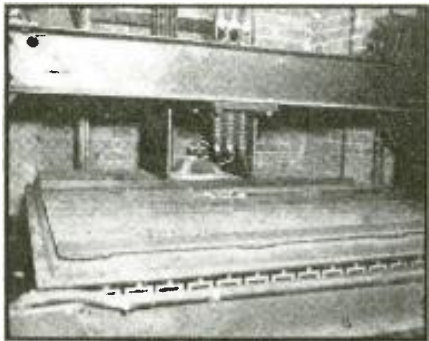

"AT LAST! ELEVATOR RADIO!"

Philco announces radio for elevators. The receiver is located at the top of the shaft (to eliminate radio interference), and is operated by means of wired remote control from a pushbutton panel located in the elevator car within easy reach of the operator. Standard elevator cable is used for the wired remote control. Two reversible motors in the receiver provide for tone and volume control, the latter also being ganged with the "on-off" switch. The receiver is an 11-tube console (Philco Model 295), complete with a loop antenna. The cost of installation increases with the height of the building. In the top photo is shown the pushbutton control installation, located directly above the elevator control switches. The photo in the center shows the speaker (its case removed) installed on the roof of the elevator. The lower photo shows the speaker installation as viewed from inside the elevator.

## PREPAREDNESS

"IN connection with national defense training, the Civilian Conservation Corps contemplates establishing radio courses to make commercial operators at possibly 1,000 camps, and desires preliminary data on the availability of about 1,000 instructors if the program is undertaken," S.R.C. *Ham News* advised its readers last month.

National Union Radio Corp. has contributed in its own way, toward helping the general preparedness program, by agreeing to extend the Equipment Contract of any Service Dealer conscripted for military service.

RCA, in order to expand its research and production facilities to be able to handle large national defense orders, has borrowed \$15,000,000.

## SOUND

PATENT No. 2,216,970, granted to William T. Walker, last month, and assigned to RCA, describes how a slight amount—about 1 to 3%—of "carbon black," added to the conventional recording wax, not only improves the cutting of the stylus but, more important, eliminates "tick" sounds due to static electricity generated when a sapphire cutting-stylus is used.

The house of Bell & Howell, well-known for its line of 16-mm. motion picture cameras, last month ventured to invade the sound field by announcing a combination disc recorder and record player, the latter for connection to any standard radio set.

Philco last month introduced 2 new metal-base sound-recording blanks having an exceptionally fine grain which minimizes needle scratch.

"Dr. and Mrs. Clifton Wemple, newlyweds of Susanville, Calif., unwittingly were

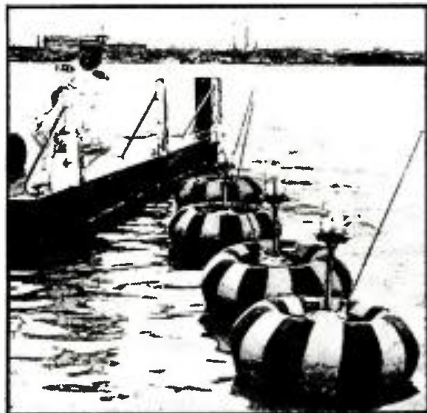

RADIO LIGHTS

Harbors, lakes and rivers may be turned into seadromes by stringing radio-controlled lights out in landing lanes. The fluorescent lights, operated by batteries, have radio receivers in the bases of mountings supported by inflated rubber floats. The lights may be turned on and off by shortwave radio from shore stations 6 miles distant. Red and green lights are employed to indicate wind direction. Westinghouse engineers worked out the radio equipment; and Firestone Tire & Rubber Company worked out the doughnut-shaped rubber floats.



"THE ADVANCE PATROL REPORTS . . . !"  
(Cover Feature)

The U.S. Army is equipping its Advance Patrol Units with three "Walkie-Talkie" transceivers to facilitate contact with headquarters and with operating units. Here Private Fred Kohler, of the U.S. Army Signal Corps, is shown with a portable shortwave radio, being used in the recent war games of the Army and Navy on the Northern California Coast. The equipment has a 5-mile range.

the cause of the most revolutionary innovation to the wedding ceremony since the advent of marriage certificates and tin-type photographs," is the way Philco's publicity dept. modestly introduces a description of a home-recorded wedding. The bride-to-be's brother and an enterprising home-appliance dealer conspired to conceal the microphone, and its leads to the sound-recorder, before the ceremony. The result: a treasured gift, to bride and groom, of the "Do you . . ." 's of the Reverend, and the "I do" 's of the newlyweds.

Obtained somewhat less dramatically, but equally treasured, were the recordings made last month at the wedding of Juanita Burdge and Harold B. Rosenberger of Kenton, Ohio, reported A.P.

Wired music may soon spring a surprise. According to Henry Lee, writing in the *World-Telegram* last month, Muzak has been experimenting with sending music over power lines in the county of Queens (New York City), as a less expensive means of bringing wired music right into homes. However, Muzak now is nursing the idea of using Frequency Modulation as a means of feeding its advertising-free music to the big home market.

At the "voice clinic" conducted by the New York Telephone Company for those who handle calls at switchboards in private offices and other places of business, sound recordings help correct voice defects. In the classwork, 2 of the 10 "students" in the group carry on a conversation, one taking the part of a calling customer and the other the part of an attendant at a P.B.X. switchboard. This conversation is recorded on magnetic tape—a sort of "voice mirror"—and is then played back so that all of the members of the class, listening with earphones, can hear. The recorded speech is then analyzed by the voice instructor and the pupil, and ways to improve it are discussed and tried. When it is recalled that there are more than 35,000 private branch exchanges in New York State alone, the practicality of this newest application of sound recording becomes apparent.



**TECHNICAL**

**T**HE Radio Traffic Control on the George Washington Bridge (See "550 on your Dial!", *Radio-Craft*, Nov. '40) between New York City and Fort Lee, N. J., has been discontinued. Engineers have concluded that at the present time the possibilities of this system are limited. For instance, the regular travelers across this span during the Winter months do not require guidance. And besides, one newspaper concludes, "most of the cars which cross the bridge are not equipped with radios."

Alnico, when it made its debut to most technicians, was treated like an ugly duckling. It wasn't long, however, before its use in permanent-magnet loudspeakers almost wiped the field-coil loudspeakers off the market. Therefore, perhaps we should eliminate the ugly duckling stage in connection with "Vicalloy", the newest magnetic alloy to come from the almost magical laboratories of the Bell Telephone Co.

Vicalloy (v=vanadium, i=iron, and c=cobalt), unlike other magnetic materials, can be drawn or rolled into shapes for many uses. For example, it has been rolled into tape only 1/500-in. thick and 1/20-in. wide. Several thousand feet of such tape have been used for sound-recording. The weather-announcing systems, for instance, use this tape. It holds more magnetism than does any other alloy.

On its toes, Emerson is the first set maker to catch a patriotic motif in its receiver styling. The new "Patriot" model superhet. is available in basic blue with white and red trimming; and in the remaining combinations with basic white or red. The set serves also to commemorate the 25th Anniversary of Emerson Radio Co. which last month completed its 4-millionth radio set.

"Acoustivanes" have been incorporated in the new C.B.S. Studio Building. Like the sound-deflecting, movable panels used in German broadcast stations several years ago (as described in *Radio-Craft*), they may be adjusted to any desired degree of tilt in order to afford complete control of the acoustical characteristics of the studio.

A recent news release from *Tide* magazine states that the U. S. Army is buying standard makes of the new, highly sensitive pee-wee portable radio sets because their highly-directive loop aerials make them fine stop-gap direction finders for troop training.

A fine time was had by all when Mr. Hugh L. Rusch, Vice-President of A. C. Nielson Co., last month, delivered a lecture before the I.R.E. in Chicago on the "Audiometer." Attached to any radio receiver, it indicates (a) the time the set is in operation, (b) the exact length of time of listening to each station, and (c) when the station was tuned in and out; all of which makes possible a statistical picture of the listening habits of entire groups of the radio audience.

Newest in circuit breakers is the "Quick-lag" model developed by Westinghouse. It successfully combines for the first time in a single unit a cooperative magnetic and a thermal trip.

The combination of the bimetal thermal and the magnetic trip actions permits instantaneous trip on short-circuits and time-delay for momentary overloads such as

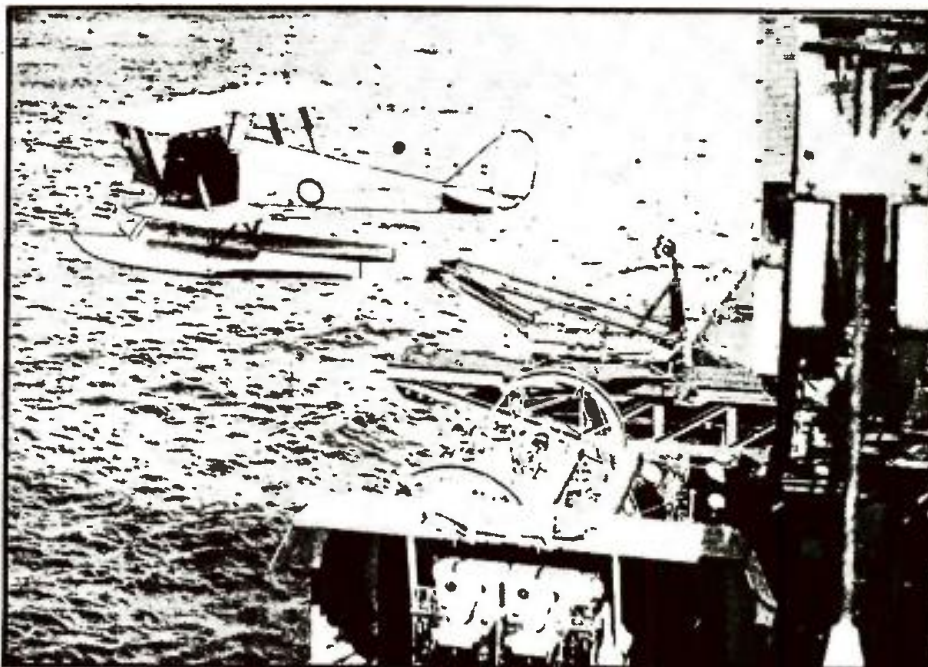

**RADIO CONTROLLED AIRPLANE** Photo—The Indian Listener  
The "Queen Bee", a radio-controlled target aircraft, is shown being catapulted from the deck of a British cruiser. The plane is capable of executing all aerial maneuvers via radio remote control. Robot planes of this type have been used in anti-aircraft training services since 1935.

those caused by a lamp, appliance, or motor inrush currents.

A new corona-resistant wire developed by Belden is suitable for the high-voltages carried in cathode-ray tube television circuits. A special rubber compound, high-heat-resisting Pyro-Glaze seal and braid of Fiberglas (pure glass) protect this wire against corona and heat. The diameter of this (white) wire is 0.2-in.

The U. S. Coast & Geodetic Survey's Mr. H. G. Dorsey last month described to members of the Acoustical Society of America, in convention at Washington, D. C., a new and so-called "safety buoy." It is equipped with a delicate mechanism that is actuated by the explosion of a tiny TNT bomb from a ship approaching, and instantly starts to send out radio signals that may be used for direction finding.

By irradiating with "black light" several fluorescent materials, airbrushed on white cloth to form an American Flag, Dr. J. W. Marden of Westinghouse Lamp Labs., last month, made the latest contribution of electronic science to patriotism. An ultraviolet lamp produced colors as follows:

Red, cadmium borate; blue, calcium tungstate; white, magnesium tungstate; green (staff), zinc silicate; yellowish-white (staff-knob), zinc beryllium silicate.

New stamps of Slovakia carry the portrait of the Rev. Josef Murgas. Radio towers shown on the stamps, are symbolic of the interest of Father Murgas in radio, who conducted radio and laboratory experiments for a museum.

The featured speaker at a joint meeting of the I.R.E. and the A.I.E.E. last month, was Sylvania's Dr. Ellefson. His topic: "Fluorescent Lighting."

Have you a little shortwave set in your home operating on the "160-meter" band? New F.C.C. regulations effective Nov. 1 shifted this channel from its old Nov. of 1,715 to 2,000 kc., to a wider range of 1,750 to 2,050 kc.

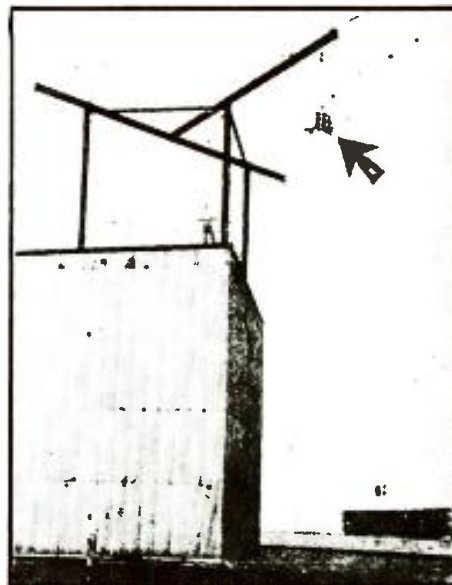

**WORLD'S LARGEST SOUNDROOM**  
This new "free-space" soundroom, nearly 10 times larger than the next largest similar structure, will permit a more accurate determination of the response and directional characteristics of loudspeakers at low frequencies and will greatly facilitate precision acoustical measurements. As shown in the photo, rigging is also provided for outdoor measurements of speakers such as the Jensen 60-cell type "K" Horns (arrow), which are equipped with 2 permanent-magnet driver units.

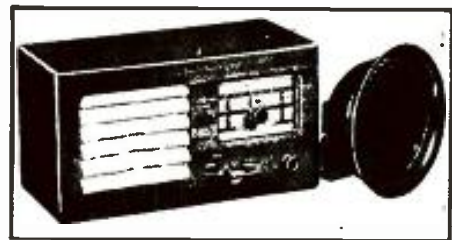

**"RADIO-INTERPHONE"**  
A simple finger control instantly converts this instrument from a radio set to an interphone system. It is designed especially for use by housewives to answer inquiries at their front doors without actually having to open the door. However, it has its uses in industry as a standard interphone system. This Satchell Carlson unit's novelty is its built-in radio set. (Diagram on pg. 437.)  
\*Also see "How to Make the Radio-Craft DeLuxe Carrier Interphone," *Radio-Craft*, May and June, 1937.

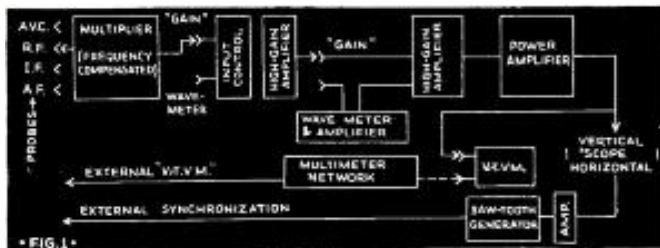

In the following discussions the author explains the applications of the oscilloscope as a radio servicing instrument.

◀ Fig. 1. Block diagram of a typical dynamic analyzer using the cathode-ray tube.

# VISUAL DYNAMIC SERVICING



Model 560 "Vedolyzer" Visual Dynamic Tester.

In order to take up the typical circuits used in the modern radio receivers it will be necessary to divide into several sections the following article on the use of the cathode-ray oscilloscope in servicing. Theory will be omitted in order that we can make this treatise provide, for present and future owners of oscilloscopic equipment, information which will be of practical value.

## TYPES OF C.-R. SCOPES

There are a number of commercial oscilloscopes on the market, each having its limitations, depending upon its design. In order to have facilities for complete dynamic analysis, other sections must be added to the conventional type of oscilloscope. Such sections are shown in the block diagram in Fig. 1 which consists of high-gain, wide-range amplifiers, frequency or wave meters, and usually a sensitive vacuum-tube voltmeter for making static measurements such as volts, ohms, etc.

The instrument illustrated in Fig. 1 is such a dynamic analyzer, having the necessary facilities for checking the hum, distortion, etc., as well as signal tracing and amplitude indications. This instrument is essentially a super-voltmeter with provisions for analyzing radio or electronic apparatus under actual operating conditions. To accomplish this, the voltmeter must have multimeter functions, input control, linear frequency response, extremely high amplification, provisions for frequency determination, and facilities for observing the quality and quantity of the voltage or signal under test.

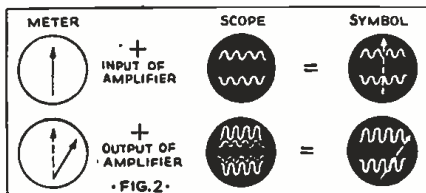

Fig. 2. Explanation (preliminary sketch) of oscillograms and meter deflections discussed in this article.

## B. O. BURLINGAME

## PART I

Since this type instrument is expected to locate defects in the passage of a signal through the various stages of a radio receiver a source of signal supply should be used which will produce an exciting voltage of good waveform and sufficient amplitude. This is necessary in order that the operator will have a standard by which to compare the quantity and quality of the voltage at the various points.

The generator or generators which should be used in conjunction with a cathode-ray type of dynamic analyzer should have:

- (1) Sine-wave output (A.F. and R.F.)
- (2) Variable A.F. and amplitude modulation.
- (3) Metered output level.
- (4) Frequency-modulated output.

In order for a radio receiver to convert the electrostatic and electromagnetic radiations into sound, the various amplifiers, detectors, etc., must have some definite operating characteristics. Thus, an instrument which is to aid in locating any type of a defect must have multimeter functions.

The multimeter section of the dynamic analyzer is used for testing operating voltages and making resistance measurements. Its controls are conventional for any type of vacuum-tube voltmeter, consisting of zero adjustments, and range and function selectors.

The oscilloscope section of the instrument has the usual number of controls for adjusting the brilliance, amplitude and sweep frequency, and also includes a meter for use as signal tracing apparatus. When both the quality and quantity of the signal are viewed simultaneously on the meter and oscilloscope respectively, the instrument may be referred to as a dynamic analyzer.

## SIGNAL TRACING SECTION

As mentioned previously, the cathode-ray oscilloscope is a voltmeter capable of indicating in 2 dimensions the results of voltage impulses in an electrical circuit. In other words, the vertical amplitude on the scope and the meter deflection is one dimension; and the time factor (horizontal deflection) which makes possible the analysis of the signal (that is, to actually see the waveform) is the other dimension. The amplitude may be called the quantity while the waveform as viewed on the scope may be called the quality.

Since the cathode-ray dynamic analyzer has 2 systems of indication and both are of equal importance in locating a defective component of a radio receiver, it will be necessary to show the results on the meter and the scope simultaneously. In order to

save space and minimize confusion, the symbols shown in Fig. 2 will be used throughout this discussion.

For example, suppose that we place the probe on the input of an amplifier which is being supplied with a modulated R.F. signal. The meter will indicate a deflection which is dependent upon the amplitude of the signal at the amplifier input. The quality or general condition of the signal will be indicated by the pattern on the screen of the cathode-ray tube. The upper circles in Fig. 2, illustrate typical results of the meter and scope, reading from left to right. If these 2 circles are superimposed upon each other, the symbol shown to the extreme right will indicate the combined results.

In order to clarify this notation a little further, let us place the probe on the output of the amplifier. The meter will show an increase if the stage is amplifying which is represented by the deflection in the lower drawings. The dotted line represents the former position of the needle which would result if no amplification was present in the stage. To the right of this figure, we have the oscillogram with the input waveform shown by the dotted line. The combined oscillogram and meter deflection is shown in the lower-right-hand corner which should be compared with the circle or symbol directly above it.

Frequently it is necessary to show D.C. voltages instead of the A.C. components on the meter. When such cases arise a notation will be made directly below the symbol such as "Meter symbol = D.C."

Referring to the block diagram of Fig. 3, we have a typical superheterodyne receiver with auxiliary sections such as power supply, automatic frequency control, automatic volume control, etc. The dynamic analyzer is set up for signal tracing by using a probe with the proper isolation resistance and switching-in the high-gain amplifiers and wavemeter. With the signal generator set to produce a 400-cycle 30% amplitude-modulated signal and connected to the antenna and ground post of the receiver, a connector should be placed from the chassis to the ground of the signal analyzer.

During this testing procedure it should be noted that it is possible to use a single probe from antenna to speaker. The reason for this unusual procedure of dynamic testing is due to the overall frequency response of the wide-range amplifier. However, to make gain measurements on the audio frequency section, we will change to the audio probe to continue the procedure.



A point-by-point description of this routine will indicate some of the variations which cannot be effectively illustrated in the diagram.

(A, B, C)—With the exception of the tubes, the power supply is a common source of trouble and it is wise to see that it is producing the proper voltages before checking the signal circuits. As to whether A, B, or C should come first depends upon the conditions of the receiver. If the receiver has excessive hum or low volume, point "A" will indicate the output and general condition of the power supply. More details will be given later concerning the various results to be expected with different rectifier and filter systems. It should also be remembered that a complete dynamic analyzer contains a multimeter for measurement of the A.C. or D.C. potentials in the power supply. For confirmation of short- or open-circuits, the ohmmeter is at the operator's disposal.

(D)—With the antenna of the receiver connected to the output of the signal generator, adjust the signal supply to about 1/4-in. deflection on the cathode-ray tube screen. This establishes a reference voltage and also shows the condition of the supply signal. This is also illustrated by point (1) of Fig. 4.

(E)—As we progress to point E, the amplification of the R.F. stage should show an increase on the meter of the instrument as well as the scope which indicates a gain. This should be checked at a frequency near the low end of the broadcast bands as open or shorted R.F. coils will indicate a decided loss if such a condition exists. See points 2, 3, and 4, Fig. 4; the darker area at point 4 represents the combined oscillator and signal frequencies.

(F)—Proceeding to the input of the 1st I.F. amplifier, we should obtain an oscillogram which shows the presence of 2 signals. Tune-in the signal with the wavemeter and see if the I.F. can be determined. For example, if we think that it is possibly a 456 kc. signal at this point, set the function selector to "B" and tune the dial in the vicinity of 456. If a peak is received, which confirms the frequency of the I.F. signal, proceed to point "G".

(G, H)—If the I.F. signal does not seem to be present, check back on the oscillator at point F-F. This may be done in either the Gain or Wavemeter position and the variable condenser of the receiver should be varied to observe the amplitude of the oscillator voltage over the entire band. If the signal is present and in good condition at G, check for amplification at point H. Figure 4, points 7-8, illustrate this part of the procedure, also.

(I)—At this point, there is quite a contrast in the results obtained with channel-type instruments since the cathode-ray type of dynamic analyzer does not rectify the R.F. voltage. The results of the rectifier or detector in the receiver show the presence of the R.F. signal, a common cause of distortion if it is not properly filtered out at J. (Points 9-10 of Fig. 4 show 2 points to be checked to observe demodulation and filtering action).

(K)—If the filtering action was effective in the output of the detector, a clean audio signal will result at this point. If the filtering was not satisfactory, a modified form of the wave-form at point 10 of Fig. 4 will result.

(L)—The voltage at the voice coil should be similar to that of the preceding stage with the exception of the amplitude, which

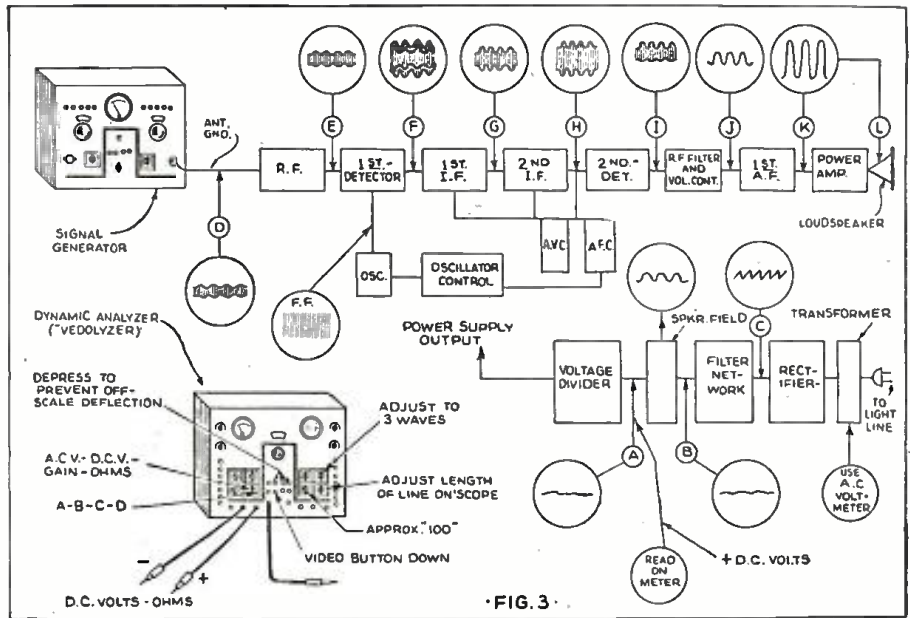

Tracing the signal through a typical superheterodyne receiver.

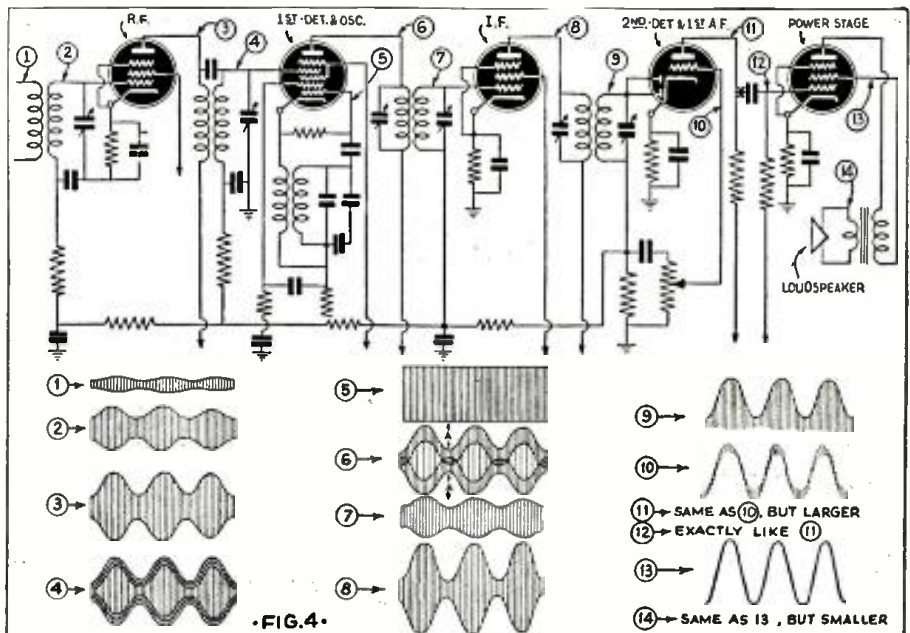

Principal points to be checked in routine signal tracing.

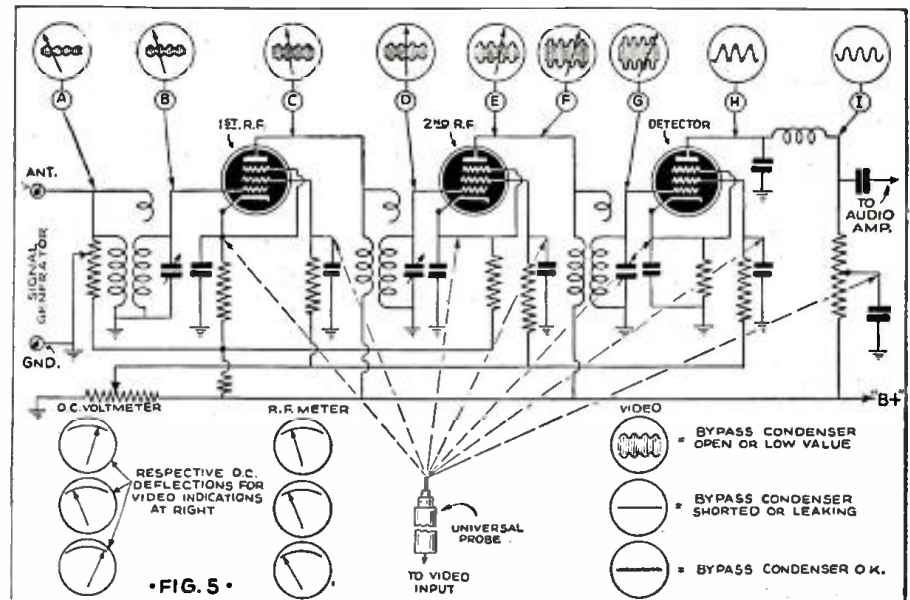

Tracing signal through a typical T.R.F. receiver; and, typical testing of bypass condensers.

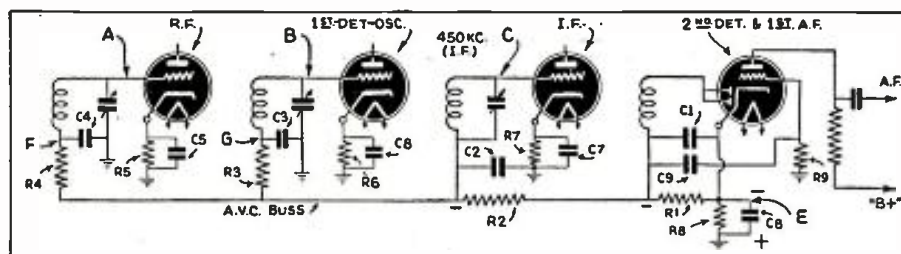

Fig. 6. Automatic volume control voltage distribution system in typical superheterodyne.

is usually somewhat lower due to the step-down turns ratio of the output transformer.

## THE T.R.F. AMPLIFIER

In the previous routine we analyzed a superheterodyne which was assumed to be operating properly. This procedure is general and may be applied to any system which represents sections of the superheterodyne. The R.F. and I.F. stages in a superheterodyne are somewhat like the stages of a tuned radio frequency (T.R.F.) receiver, and consequently, there will be a similarity in the general testing procedure.

To locate a defective part in a radio receiver, the usual method is to determine the faulty stage by the general routine and then check the individual components for the cause.

Figure 5 shows the tuning and detector sections of a typical T.R.F. circuit. The generator is connected to the antenna post, the ground to the chassis and the testing starts with the input of the receiver. The dynamic analyzer is set up as a signal tracer (see Fig. 2) and points A, B and C checked in order with the R.F. probe only. The function selector may be used in either the Gain position or Wavemeter ("A, B, C and D") with the dial set to the frequency of the signal generator. (The ground wire of the dynamic analyzer should be connected to the chassis of the receiver.)

The following steps indicate some of the possible effects:

### Point A—

- No signal: Generator producing signal?
- Continuity from antenna to Point A?
- Position of volume Control?

Low Signal: Shorted Volume Control?

### Point B—(Meter-scope should indicate gain)

- No Signal or loss of gain:
- Circuit in tune with generator frequency?
- Shorted condenser plates?

Low Signal or loss in gain:

- Circuit in tune?
- Shorted condenser plates or coil terminals?
- Open coil?
- Shorted grid in tube?

Point C—(Meter-scope should show large increase)

- No Signal: Plate, screen-grid and control-grid voltage normal?
- Bypass condenser shorted or open?
- Tube filaments? (Measure voltage at socket contacts.)
- Tube emission? (Check on tube tester or substitute tube.)

Low Signal: Operating voltage?

- Type?
- Shorted turns in coil?
- Leaking or low-value bypass condensers?

Points D, E, F and G same as points A, B and C.

Point H—(Should indicate rectified signal.)

No Detection: Check as in Point C.

Point I—(Should be almost pure sine-wave.)

- Distortion and lower than Point H:
- Open choke coil.
- Distortion and approximately same amplitude as H:
- Check for open condenser.
- Check bias voltage on tube.

## THE SUPERHET. RECEIVER

The block diagram of Fig. 4 gives the general checking procedure for the common type of superheterodyne circuit. This section will be devoted to separate parts of a superheterodyne receiver and variations which require individual tests. This will include A.V.C., Detectors, Oscillators, A.F.C., Visual Alignment and Intermittents.

Heretofore, we have used the dynamic analyzer only as a signal tracer with the

universal probe. Since some of the above-mentioned sections will require some changes in the probes and controls, it will be proper to examine the functions of the dynamic analyzer with respect to the application.

## MEASUREMENT OF A.V.C. VOLTAGE

To measure the A.V.C. voltage, the regular test leads should be used in the multi-meter pin-jacks. In order to prevent the probe capacity from detuning the circuit, a resistor should be placed in series with one of the leads. The measurement may be made by placing the negative probe on the A.V.C. buss or tube grid. By tuning the signal in and then out, the effect of the A.V.C. action will be observed. The voltages should be checked at the points indicated in Fig. 6 which is a schematic diagram of a typical superheterodyne with automatic volume control on R.F. and I.F. amplifiers.

## CHECKING RECEIVER POWER SUPPLY

The power supply is common to all of the circuits of a receiver which use the vacuum tube and, as a rule, many causes for radio failure originate in this particular section. The type of power supply depends upon the location in which the receiver is used and also the quality of the instrument. In sections where electric power is available, the A.C. and A.C.-D.C. sets will be found in the majority. In the rural sections which do not have electrification, the battery type of receiver will predominate in number. The variation in quality is represented by the small A.C.-D.C. compacts using an inexpensive half-wave system and the better grade of receivers using the full-wave system with a transformer. These small inexpensive receivers are found in large numbers due to the cost and portability. Some localities have a direct current supply, thus making a market for the D.C. receivers. The sets which are built for use in the D.C. districts will usually be of standard quality and the filter system is designed to remove most of the commutator ripple caused by the D.C. generator. Since there are several popular types of power supplies, it will be necessary to discuss each one separately in order to illustrate the defects as indicated on the dynamic analyzer.

Part II, in the February issue, will conclude this series of articles.

This article has been prepared from data supplied by courtesy of Supreme Instruments Corporation.

## JOE BIER REMINISCES AFTER 19 YEARS IN RADIO

Veteran WOR announcer Joe Bier, who celebrated his first decade at WOR on September 15, in a nostalgic mood started to reminisce about the old days of radio. Joe faced his first microphone 'way back in the days of 1921. He remembers when:

A good pair of headphones cost \$15.

Crystal sets were replaced by 1-tube receivers, price \$55.

The control engineer was in the same room as the announcer.

Graham MacNamee and Phillips Carlin handled the first World Series ever broadcast.

Announcers identified themselves over the air with initials.

All stations shared time on the same wavelength, 360 meters.

Major Andrew White broadcast prize fights.

The Eveready Hour was the first 60-minute commercial show.

Vaughn de Leath was the original "Radio Girl" over WDT, Manhattan.

Everyone listened to Roxy and His Gang, —Yascha Bunchuk, Marie Gambarelli, Wee Willie Robyn.

"The Silver Masked Tenor," Joe White, was a top singer of the day.

Paul Oliver and Olive Palmer sang for a soap sponsor.

"Amos and Andy" were Sam and Henry. Henry Burbig was the Number One radio comedian.

Everyone listened to the "Happiness Boys."

Wendell Hall was "The Red Headed Music Maker."

WOR guided the lost Shenandoah back to Lakehurst in a storm.

Getting distance—KDKA, Pittsburgh—was a big thrill.

(Aside to Editors: You and your readers can probably add a lot more Remember Whens to this list.)

(Aside to WOR's press dept.: Maybe we will —another time, but right now we'd like to give our readers first try.)

## A "SOUND" ARGUMENT

Scrutiny of the script of Johns-Manville's air program, "Sound and Sound Control," broadcast recently from this company's model radio studio at the New York World's Fair revealed the following item which sound specialists may find of interest.

"The New York Noise Abatement Commission has reported that sudden loud noises produce a rise in the brain pressure and in the rate of respiration, and an increase in blood pressure. An eminent authority has also stated that nervous indigestion may be a result of loud noises which cause a decrease in the flow of saliva and gastric juices. For this reason without knowing it, most people prefer to dine in restaurants where there is quiet, and energy does not have to be expended to raise voices over the din of dishes, kitchen equipment, cash registers, and so forth."

Next time you need an additional argument to sell a customer a job of acoustic treatment of a restaurant, etc., to improve the performance of the sound system, you might try the one given above.



# BRITAIN'S WARTIME RADIO PROBLEMS

*The author describes how the exigencies of the war in Europe are affecting the design of broadcast radio receivers in England. Economies are being made in many directions.*

M. E. SOUTHALL  
A London Service Engineer

THE effect of the great struggle in which Britain is engaged practically single handed has evolved itself into a war of metals. The great armament and munitions efforts together with the enormous air force expansion scheme has forced the Government Services to take all the various kinds of metals it requires at the expense of the manufacturers of domestic equipment.

We are concerned here only with the problem as it affects the radio market and in this sphere practically all metals are concerned, together with an additional problem due to the shortage of timber due to the closing of the Scandinavian importations.

## USE OF BAKELITE

Bakelite cabinets have enjoyed a certain amount of popularity in the cheaper radio receiver trade but in the medium and higher priced markets the demand has always been for a well-designed, solid cabinet of unpretentious appearance.

The timber shortage, however, has proved such a major problem that at least one well-known manufacturer noted for his fine cabinet work in the past has brought out bakelite cabinets for sale on the home market. For export purposes most of the larger manufacturers are still able to obtain their requirements under Government permits both with regard to wood and to other materials which are withheld from home market production.

Manufacturers who have prided themselves in the quality of their receivers' reproduction have, at first, found it rather difficult to keep up their high standard with bakelite cabinets not only because of the different acoustic properties of the new material but also because, generally speaking, the bakelite cabinet is smaller for reasons of economy and construction and this allows only a small loudspeaker baffle area.

After the wood problem the next difficulty to be overcome concerns metal supplies and in this direction bakelite chassis are being experimented with. These, generally, are not molded but are made up of rectangular pieces, one large piece forming the deck of the chassis with strips about 2 inches wide fixed to the edges of the deck with metal angle pieces. (See photos.) When such a construction is properly braced it is very strong and will easily carry without stress all the normal components that go to make up a radio receiver.

An interesting point in connection with

## ... 'Midst England's Air Raids

Dear Editor:

There is an article from me on its way to you (I hope!) dealing with the effect of the war on British receiver design which you may feel like putting into the January, 1941, issue of your journal. It was posted on September 24th and should not be so long getting to you as was your last letter to me. I am writing you more fully in a few days when the article is completed.

My district is having its quota of air raids but they do not stop us getting on with our job. I am a voluntary member of the A.R.P. (Air Raids Precaution organization) and between the beginning and ending of drafting this letter have careered up the road to help extinguish a load of incendiary bombs that fell around us. Our boys were right on the job and all fires were put right out before the official fire brigades came on the scene. Of course, all the householders cooperate with us and buckets of water and sand are to be found outside most people's front door for use by anyone wanting them.

The German plane overhead flew round and round waiting for a nice red, glowing target to appear but must have been sorely put out as he dropped a load of H.E. bombs that fell harmlessly in a field hundreds of yards away.

I'll have to write a non-technical article for one of your American journals one of these days (or nights) on the adventures of an A.R.P. warden. Do you think any editors would be interested?

Well, the old flag is flying high and we are all glad to know that most of you over there are with us in your thoughts and practical help.

M. E. SOUTHALL,  
Middlesex,  
England.

the use of bakelite chassis is that in many cases where the more popular 4- or 5-valve superhet. circuits are concerned very little trouble is experienced from instability, despite the absence of the screening effect of a metal chassis. Sensitivity is just as good, whereas on first consideration it would be expected that lack of screening would promote instability which in turn would have to be dealt with by the introduction of damping in various forms which would decrease the gain of the receiver.

The mains (*see Footnote*) transformer is the heaviest component part of a receiver and several makers will overcome the difficulty of its inclusion on a bakelite chassis at the same time as they will economize in the materials required for its construction by making only A.C./D.C. receivers which, of course, require no mains transformer.

A smoothing choke is generally necessary in A.C./D.C. receivers but they are of very simple construction compared with mains transformers and a considerable saving in money and materials is effected by doing away with the transformer.

Footnote—The English spelling of the author's words has been retained, in this article, and the English technical terms it contains are self-explanatory.

## A.C./D.C. SETS

Of course, A.C./D.C. models do not generally have abnormal sensitivity or output powers due to the limitations imposed by the voltage from the mains supply which prevents the employment of high potentials on the H.T. (high-tension or -voltage) circuits. Many designers have produced receivers with bakelite chassis with no screening cans round the I.F. transformer and using the new type of electrolytic smoothing and decoupling condensers which use a cardboard container instead of the familiar aluminum can.

Other circuit arrangements which will be used in preference to accepted patterns due to war conditions will be an endeavor to use series-capacity L.F. coupling wherever possible to save the intervalve transformer; and where pickup terminals are provided on A.C./D.C. chassis the usual isolation transformer will be supplanted by a condenser in each of the pickup input connections.

The use of a small bakelite cabinet and A.C./D.C. circuits raises another problem for designers—the dissipation of heat from the voltage dropping resistance or ballast tube. Although the use of line cords is quite common in America the employment of them in British-made receivers has not found favour. It is probable, however, that necessity will now force them upon the attention of receiver designers as their use is obviously a way out of the difficulty.

With regard to the radio-gramophones these will probably suffer a partial eclipse due to the comparatively large amount of timber required for their construction and this may be met by encouraging the market for record players which require far less wood in their construction and could, no doubt, be made from bakelite.

Turntable motors have become smaller

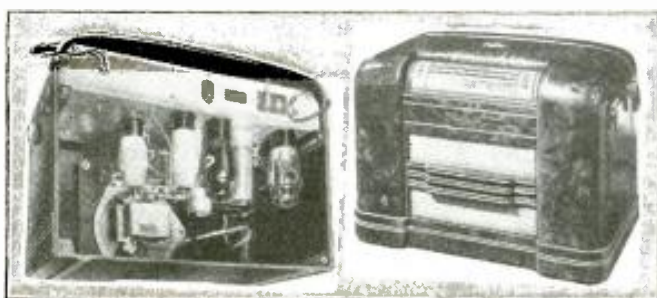

Not an upside-down view, but the interior (left) and exterior of the British war-time Marconi-phone model 911 receiver; and their first bakelite-cabinet and last metal-chassis job. This design permits use of an abbreviated chassis having no sides or front.

and smaller during the last few years and quite likely still smaller examples will be tried out employing units of high r.p.m. and geared down to give the required speed and playing torque. Tuning motors have been used quite successfully.

The coming winter may see difficulties in the supply of pilot lamps due to the demand for hand-torch bulbs. In districts where the mains voltage is high and where pilot lamps give an unsatisfactory life demanding frequent replacements it will be the duty of every dealer and Serviceman to prevent wasteful replacements of pilot lamps. The trouble is most generally met in sets in which the pilot lamps are fed directly from the heater circuit of the now widely used 6.3-V. valves. Although pilot lamps may be rated to operate on 6 V. or more they are not really happy when constantly run at this voltage and if a resistance of about 9 ohms is fitted in series with the pilot lamp the voltage applied to the lamp will be reduced to about 4 V. and its life will be considerably lengthened. The reduction in scale illumination is by no means serious.

Some manufacturers have already taken care of this point by feeding the pilot lamps from a separate 4 V. tap on the heater wiring of the mains transformer, while others are fitting series resistances of the spaghetti type. It would be advisable also, as far as possible to reduce the number of pilot lamps in the receiver so that only 1 or 2 are used, which will be sufficient to indicate whether or not the set is switched on. Many makers are doing this in new models and dealers can advise customers to take out the bulbs that are not essential in their existing receivers and to keep them as spares.

## BATTERY RECEIVERS

Last winter there was a tremendous demand for torch batteries due to the fact that very few of the 40-odd-million inhabitants had ever possessed a hand-torch and those that did have them did not use them extensively and required only infrequent battery replacements. Consequently when our first blackout winter descended upon us there was such a demand for torch batteries that most H.T. battery manufacturers found it imperative to curtail their H.T. battery programme and to concentrate on the making of torch batteries. Even so, large numbers of radio dealers were unable to get supplies for their torch battery sideline trade and resorted to the practice—which was, by the way, quite a profitable one—of breaking up H.T. batteries into 2-cell units and selling these for use in torches.

This winter the situation should be a little easier but the rationing of the ingredients necessary for the manufacture of drycells will add its problem to the existing ones. The net result of all this is that owners of battery receivers must make their batteries last as long as possible and the method by which this can be accomplished may be of interest to readers who one day may be faced with the same problem.

## BATTERY ECONOMY

Firstly, of course, the receiver should be used as little as possible such as for news bulletins and star programmes, etc., instead of being left on for most part of the day as a background to normal domestic activities. This form of economizing is, of course, voluntary and is somewhat out of the control of the actual owner of the receiver who may be away from home on business for the greater part of the day. A certain amount of forced battery consumption must be resorted to, therefore, and one method which

The electrolyte escaping from a faulty cell in a battery will creep over the bottom of the battery and make a short-circuit path.

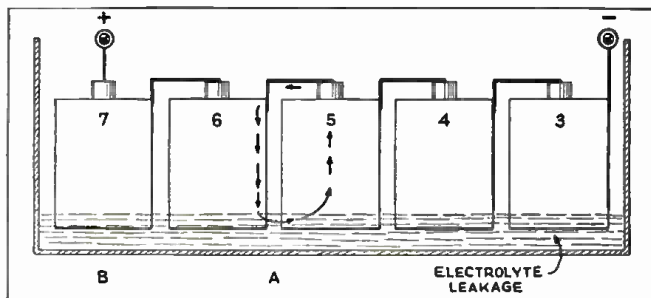

is popular is to reduce the output of the last stage which is the greatest consumer of H.T. current by reducing the H.T. voltage applied to it or by increasing the bias voltage. This means that distortion will be evident at a lower volume of reproduction but as we are all requested by the authorities to keep our radio reproduction at a low level so as not to interfere with the daytime sleep of the night-shift factory workers this curtailment of quality reproduction is not serious.

Many battery receivers are designed with what are termed "battery economizer switches" which when operated by the user, bring into circuit a comparatively high resistance in the main H.T. positive feed to all valve circuits and so reduces the total consumption of the receiver.

Another slight gain which, nevertheless, is effective over a long period is the improvement in the efficiency of the aerial and earth systems. By putting up a really good, high aerial instead of using a piece of wire round the picture rail and by installing a proper earth connection a much bigger signal is passed to the receiver. This means that the A.V.C. circuits come into action by applying more bias to the early valves in the receiver, reduce their anode currents and thus cut down the total current taken from the H.T. battery. Up to 1.5 ma. can be saved in this way.

## "LEGITIMATE" LIFE CLAIMS

Many people who have never previously owned a battery receiver have bought them as standby sets in case of a major failure in the electricity supply service which will prevent them using their radios and hearing important announcements from official sources. These people have often used their new receivers as a second instrument in the house and are rather surprised at the life of the H.T. battery. Being used to operating a mains model most of the day they are inclined to use the battery receiver in a similar way and so find that a replacement battery is soon required. Their first thought, naturally, is that the battery must be faulty and when they take it back to the shop they generally considerably under-estimate the number of hours per day during which they have used the receiver when discussing the matter with the dealer. These people have to be educated in the limitations of battery receivers.

Of course an H.T. battery can be run down after only a very short life due to leakage from a faulty cell. The electrolyte escaping from the cell will creep over the bottom of the battery and make a short-circuit path for all the cells except the last one which is generally referred to as the positive cell.

This cell can never be discharged by internal short-circuits whereas all the others can as will be appreciated by a glance at the accompanying drawing. At A, cell 5 is shown discharging through the zinc of the cell and the electrolyte which has "crept" over all the bottom of the battery. At B,

cell 7 (the positive cell) has no connection from its positive cell terminal and therefore cannot discharge itself. By testing this cell, therefore, by means of a sharp prod which will penetrate the cardboard container of the battery and make contact with the zinc can of the positive cell, and using this connection to take a quick voltage test across a 10-ohm load it can be ascertained whether the battery has been run down by internal or external conditions.

If the voltage of the cell is about 1.4 V. then this indicates a faulty battery but if the cell shows a much lower voltage then it is proved that the whole battery of cells including the positive cell has been run down due to current being taken from the battery and upon the results of the test a firm attitude may be taken up with either the customer or battery manufacturer.

It may, at first sight, appear that many of the modifications now being made under pressure of war conditions will be retained even when supplies are more plentiful but this does not necessarily follow. For example, a bakelite chassis has to be bolted together to separate angle pieces, braces, etc., and special earthing facilities provided, all of which take time and labor, whereas a metal chassis can be shaped and all the necessary holes and earthing lugs pierced in one operation thus making the process extremely economical even for small receivers. Nevertheless there are sure to be many features now seeing the light of day for the first time in British war-time receivers which will remain with us and remind us of our endeavors to keep the public in contact with one of the most essential National Services of these perilous days.

Radio-Craft readers who are following these interesting first-hand reports of radio conditions in war-torn Europe will recall Mr. Southall's article "Television Servicing Problems" in the November, 1940, issue. His comments in the current article, above, may be of interest to manufacturers who are cooperating in America's Defense Program.—Editor

## RELATIVE PERFORMANCE OF LOOP AND LINE ANTENNA SETS

IN an effort to simplify radio reception as much as possible by eliminating outside aerials, radio manufacturers have developed a number of special built-in antenna systems. The 2 most important of these are (1) the built-in line antenna and (2) the loop antenna (both of which are used by Stewart-Warner).

It is not possible to state that either one is definitely superior to the other in all cases. Both have their advantages and disadvantages. Since the dealer sells both types, it is important that he know under which conditions they provide their best performance.

A set having a built-in line antenna uses one side of the power line as the antenna and the other side as ground. In rural locations, where the wiring may be open, and not in steel conduit, a line antenna provides very good signal pick-up and will almost invariably prove vastly superior to the loop. In a city home, which uses en-



closed conduit wiring, there may not be very much difference in pick-up between the line antenna and the loop. If there is some exposed wiring such as extension cords, pick-up with the line antenna may be quite good even if most of the house wiring is in conduit. On a dealer's floor, where all the wiring is shielded, and a number of sets use the same wiring circuit, the line antenna will probably work very poorly.

A very important characteristic of the loop antenna is that it is directional and that either the set or aerial must be rotated so as to point to the station. This will prove an inconvenience, particularly in the case of non-portable sets, so that usually the radio owner won't do it, to the detriment of certain stations that are in the direction of minimum pick-up. On the other hand, the directional feature may be of advantage in reducing interference in some cases.

If more than one set is used on the same line, and at least one of the sets is not of the line-antenna type, the line-antenna set will usually show up very poorly, since many sets make use of a buffer condenser across the line, which acts as a short-circuit for the line-antenna set and prevents any signal from getting through to it.

Although the relative pick-up of the loop and line antennas will depend very considerably on such local conditions as described above, the situation is entirely different when an outside aerial is used. *A line-antenna set, when used with an outside aerial, is definitely superior to a loop-antenna set of equal sensitivity when used with the same outside aerial.*

M. J. SCHINKE,  
Service Department,  
Stewart-Warner.

### GETTING A STATION ON THE AIR

THOSE up-with-the-sun listeners who hear the various metropolitan stations sign on the air every day with a cheery "Good Morning" probably think that the start of another day's broadcasting is easy as throwing a switch.

It isn't. The night shift of engineers who prepare the big 50,000-watt transmitter of WOR for another day's work must go through 44 separate moves requiring over three-quarters of an hour before you hear that early morning announcer say "Good morning."

It's scientific, painstaking work, marked by a progression of check and recheck steps that must be accurate to the Nth degree if the radio listener is to have 100% reception for 20 hours each day.

The process of placing WOR on the air—and WOR last year operated 8,221 hours without a second's loss of time—begins before 5:15 A.M. First the tube filaments are turned on and allowed to heat while the crew of engineers go over the "innards" of the transmitter, checking every circuit, cleaning out specks of dust and continually testing. Other engineers check the antenna feedline to the transmitter. Finally, when all is considered shipshape, the station is placed on the air for 2 minutes with low power—just long enough to take readings of meters required by the government. After the power goes off, the engineers give the transmitter another check.

Then 5 minutes are spent giving the giant tubes a general examination as 17,000 volts are applied to their plates. Two more engineers test the wire lines between the transmitter at Carteret, N. J., and the WOR studios in New York, which are 20 miles apart. These wire lines must convey the

radio programs all day long without a flaw or failure.

Every single one of the 44 different steps is accompanied by extensive measurements that are jotted down in big logs for future reference. Shortly after 6 o'clock the carrier wave itself is switched on. This is the same as if the station were transmitting, but without "modulation" or voices and music. Once again all meters, wire lines, power input and output, antenna and switches are checked. Then at 5:59½—after all 44 steps have been taken—the first chimes flash over the wire line from New York. The engineer at the control desk in Carteret taps back an "OK" in code via the Morse telegraph line that parallels the program line. The time "peep" at 6 A.M. goes over the air. All is well—WOR is on the air with the full force of its 50,000 watts for another day.

Seven log books are needed to keep track of all operations—a starting log, master operating log, Federal Communications Commission log, day and night maintenance list, work to be done and special maintenance logs, plus tube records. It also takes a lot of pencils.

### DOES CODE BEAT 'PHONE?

"Rear Admiral Hooper spoke at a recent Washington Radio Club Annual Dinner. He lauded A.R.R.L., and especially our 'Key Men,' 'Knights of the Brass.' As he expressed it, our c.w. men, operators, are one of the United States' greatest reserve assets. He said 'phone was of limited use in time of war, easily intercepted, and impractical for cipher, coded orders, and uses not meant for spot execution and action."—From QST magazine.



## Type D UNIVERSAL Controls



### STOP WASTING TIME ON VOLUME CONTROL REPLACEMENTS



**FREE!**

The 18 Type D Controls, 6 switches and 5 extra Tap-in Shafts, factory-packed in this IRC Master Radiotrician's Cabinet, handle from 60% to 75% of all control replacements. You pay only \$14.97 net—the standard price of the controls, switches and shafts. The Cabinet (of dust-proof, all-metal construction) is included at no extra cost. Ask your IRC jobber to show it to you or write for folder. It's a time-saving, money-saving development no serviceman will want to miss!

Stop wasting time by ordering a volume control every time you need one for a job! Stop wasting time puzzling how to fit a control with shaft attached into a crowded chassis without removing other parts! Stop wasting time waiting for a more costly "special" replacement, when a standard IRC Type D Universal Volume Control with a special Tap-in Shaft will turn the trick!

In short, use IRC Type D Controls with Tap-in Shafts *universally*. Learn how a stock of only 18 of these controls equips you for prompt service on *about two-thirds of all types of replacements*. Study the construction of these sturdy little controls and see how amazingly superior Type D's are to ordinary midgets—fully equal in quality to the larger Type C Controls and with all the same features *plus* the added convenience of Tap-in Shafts which make them far more universal in use and much easier to install in a crowded receiver. Catalog free.



**Tap-in Shafts Stay Put!  
Don't pull loose.  
Don't vibrate loose.**

INTERNATIONAL RESISTANCE CO. 401 N. BROAD ST., PHILADELPHIA, PA.

GENERAL ELECTRIC MODEL JB-508 PHONO - RADIO PORTABLE

5-Tube Superhet.; 3-Way Portable (110-V. A.C./D.C. and Self-contained Batteries); Power Selector Switch; Built-In "Beam-a-Scope" (loop antenna); Spring-wound Phono Motor; P.M. Dynamic Speaker; A.V.C.; 6-V. "A" Source; 90-V. "B" Source.

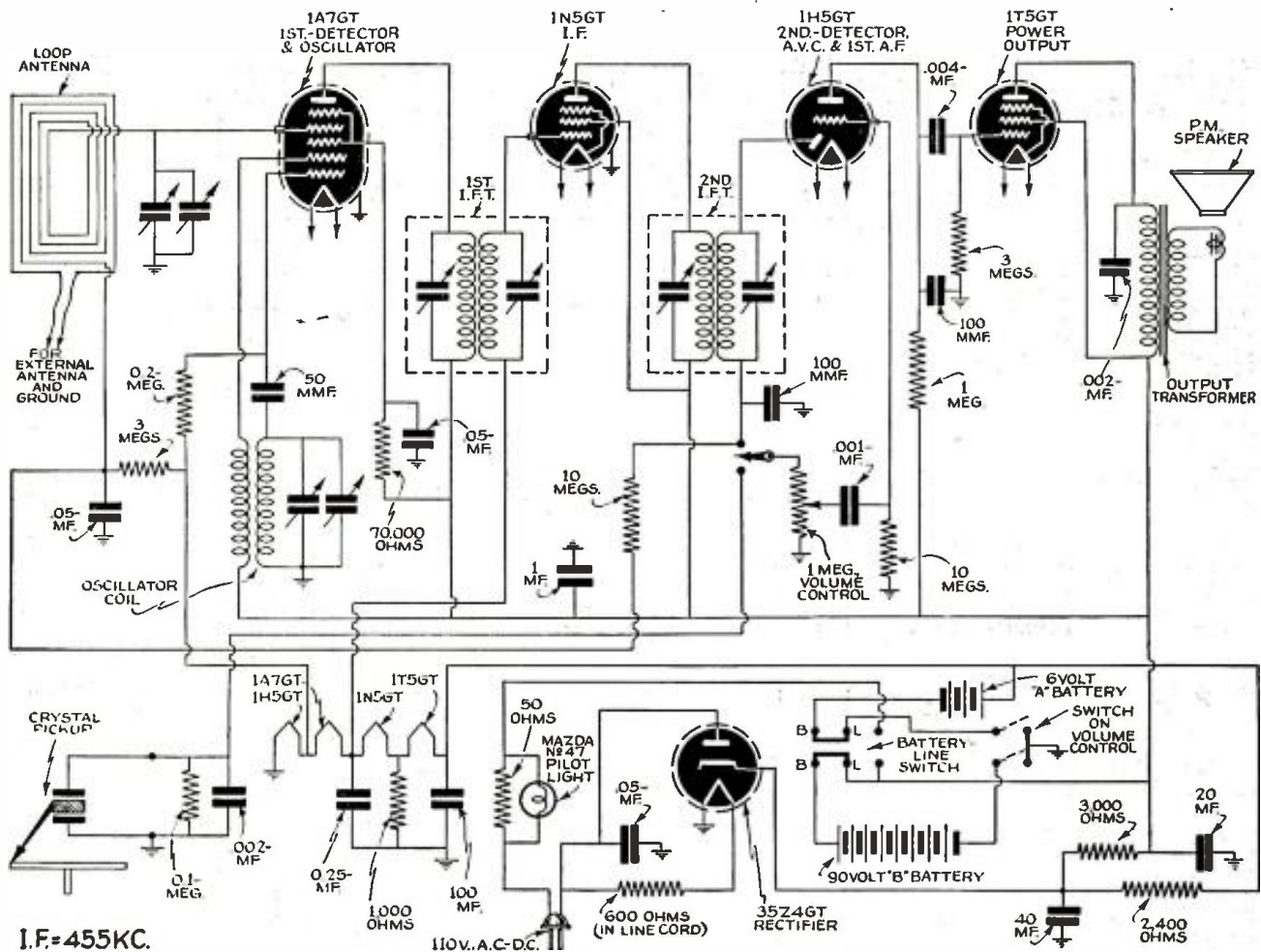

ALIGNMENT PROCEDURE

Alignment Frequencies

I.F. .... 455 kc. Broadcast—1,700 and 1,500 kc.

General Alignment Notes

This receiver must be removed from the carrying case in order to perform the alignment. Special care must be exercised to place the batteries, Beam-a-Scope (loop antenna) and chassis in the same relative positions with respect to one another as those components occupied in the case; otherwise, alignment will not be satisfactory. When aligning model JB-508 the radio-phono switch must be on "Radio."

I.F. Alignment

With batteries, Beam-a-Scope and chassis in position for alignment as mentioned above, connect an output meter across the voice coil. Rotate the volume control to maximum. Set test oscillator to 455 kc. Attach the test oscillator output leads to the 2 flexible leads of the Beam-a-Scope antenna. Keep the test oscillator output as low as a readable meter reading will permit. Adjust all I.F. trimmers for maximum output.

R.F. Alignment

Connect the signal generator output leads to the 2 flexible leads on the receiver Beam-a-Scope. Adjust the signal generator to 1,700 kc. and set the tuning condenser to minimum

capacity. Turn the trimmer screw of the cut section of the tuning condenser (oscillator) until the signal is tuned-in on the receiver. Change the signal to 1,500 kc., retune the tuning condenser to this frequency and adjust the trimmer screw of the antenna section for maximum output.

VOLTAGE CHART  
(Receiver connected to 120-V. A.C. line)

Tubes	Plate to Gnd. Volts	Screen grid to Gnd. Volts	Filament to Gnd. Volts	Filament Volts
1A7GT	92	38	3.2	1.6
1N5GT	92	92	4.8	1.6
1H5GT	10		1.6	1.6
1T5GT	88	92	6.4	1.6
35Z4GT	120 A.C.		125 Cathode to Gnd.	30

Line—120 V., A.C.

Maximum volume; gang closed; no signal input.

All voltages measured to chassis ground.

Installing Batteries

To install or replace batteries remove the 5 wood-screws which hold the motorboard in place, and raise the panel. (Note—The motor crank must be removed from the crank socket before the panel can be raised.) The panel can be freed if the 2 plug connectors are



G.E. model JB-508 phono-radio portable.

pulled out of the socket terminals in the chassis apron.

Access to the battery compartment having been made, loosen the battery block held by the wing nuts. Place the 2 "B" batteries in the bottom sections, terminals inward, and insert the two 3-prong plug connectors. The "A" cell is placed on top of the "B" batteries with terminal toward the removable block and the 2-prong plug connector attached. Replace the battery block and tighten the wing nuts.



SEND FOR THESE FREE CATALOGS  
AND SAVE TRANSPORTATION COSTS  
ON ALL YOUR RADIO EQUIPMENT

Check This Map—and See How You Save  
You Pay Shipping Charges Only From  
Your Nearest Sears Mail Order House



**Free!**

Send for these FREE books Today!  
If you want the Public Address  
Equipment book, write for F732RC-1  
... or the Radio Equipment and  
Supplies book, write for F717RC-1.

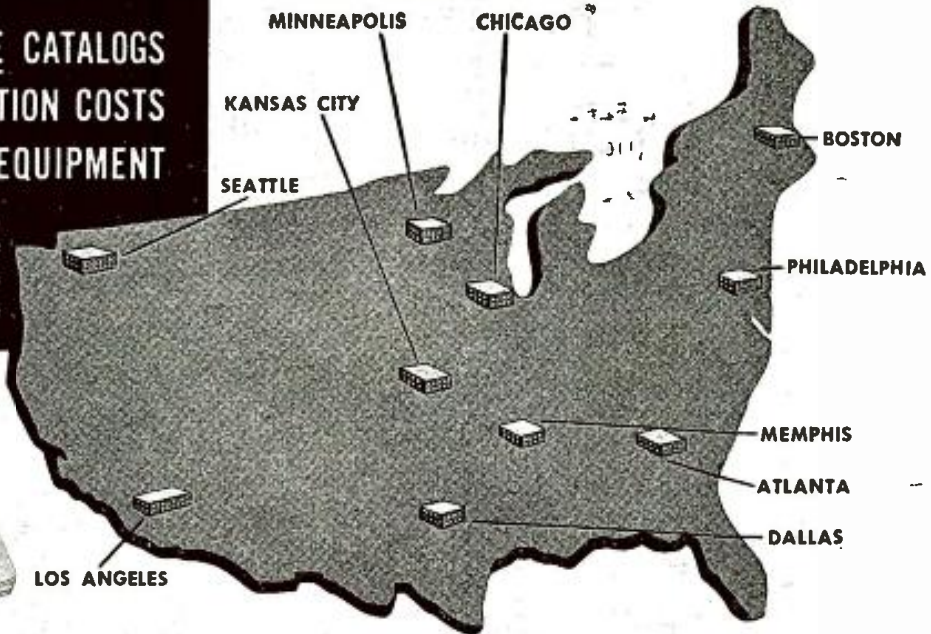

Chances are you're a Service Man or "Ham" who's "sweet" on good Radio Equipment but don't much care for high prices.

If you are, then you're in for a treat when you get your new Public Address or Radio Equipment book from Sears.

You'll see the most complete and up-to-date assortment that anyone could ask for —top-quality Equipment at those low prices

Sears are famous for. What's more, you can buy it all on Sears Easy Payment Plan!

And don't forget—when you buy from Sears, you pay shipping charges *only from your nearest Sears Mail Order House!* You'll save Time—you'll save Money—and you'll be Satisfied! Sears-Roebuck's famous Money-Back Guarantee absolutely protects you.

**SEARS, ROEBUCK AND CO.**

Chicago, Philadelphia, Boston, Kansas City, Minneapolis, Atlanta, Memphis, Dallas, Seattle, Los Angeles

**ALIGNING SUPERHETERODYNE RECEIVERS**

WE have found, from experience, the average radio set can be aligned more accurately by ear than with the use of such instruments as the oscillator, oscilloscope, etc.

After aligning a number of receivers with recognized aligning equipment we have found that the I.F.s were off as much as 3%. Of course, Servicemen who are accustomed to tolerances of 15 and 20% will say that a deviation of 3% is darn near perfect. While we feel that 3% deviation in the I.F.s is far from being perfect, we will not attempt to prove our point with a lot of technical terms and figures, but will try to describe our system of alignment without an oscillator; and why it is better in most cases.

An ordinary super. with pentagrid converter, and no R.F. stage, is designed and built by the factory and labeled 456 I.F. Due to the wiring, coupling, deviation in parts, etc., and/or production methods, no two-sets will peak exactly the same nor will the parts in any one receiver work in orderly fashion. There will be a little whistle here, a little flutter there and so-on. When alignment is attempted with an oscillator there is no impedance matching, the signal strength is not like that of a broadcast station and the oscillator is certainly not like the radio's own antenna. When the average Serviceman gets a set to align, he glances at the schematics labeled 456 kc., or whatever I.F. is used, turns on his oscillator and Heigh-O-Silver. Without taking the accuracy of his oscillator or the possible deviation in the receiver parts into consideration, he peaks the resultant signal for all it's worth.

We feel that the proper way to align a radio receiver of the above description, is to take the superheterodyne principle into consideration and align it accordingly, with its own antenna. With no R.F. stage there will be images present, provided that in the locality there are strong stations on the high-frequency end of the broadcast band. If there are no images, due to a low I.F. or an absence of strong local stations, there will always be beat notes or whistling on certain parts of the dial. Here in Detroit we have a station, WJBK, operating on 1,500 kc., and we find that if a superhet. of 456 kc. I.F. is tuned to 588 kc. on the dial, the oscillator will be oscillating at 588 kc. + 456 kc. or 1,044 kc. Since there is no station at or near 588 kc., the image 1,044 kc. + 456 kc., or 1,500 kc. (or station WJBK), will come in nicely. that is if we tune it in on the I.F. trimmers with a bakelite tuning stick by ear. It is also necessary to vary the 600-kc. padder, if any, at this time.

**SETS WITH PREAMPLIFIERS**

It is possible only after some practice to tune the I.F.s of receivers with I.F.s below 262 kc. or receivers using R.F. preselection. Receivers with R.F. preselection or I.F.s below 262 kc. will have no images below 700 kc. on the dial, and so therefore, it is necessary to tune-in the weakest station below 700 kc. Never tune the I.F.s by ear on any signal above 700 kc. Always tune-in the weakest signal on the low end of all bands with the I.F. trimmers using a non-metallic screwdriver.

We have used a 456 kc. I.F. for illustration; if it is found that the receiver has some I.F. other than 456 kc., the same principle can be used. And if a clear image cannot be had, figure out one of the beat notes present and tune it in, below 700 kc. on the dial of course.

As for the high-frequency end of the dial, no attention should be paid until after the I.F.s have been tuned. After the image has been tuned-in, pick out a weak station between 1,300 kc. and 1,500 kc. and tune it in by ear; using the oscillator trimmer.

Offset the oscillator trimmer until the signal is barely audible and tune the R.F. trimmer for maximum volume, then peak the oscillator trimmer. With the oscillator trimmer peaked it is impossible to note any changes made by adjusting the R.F. trimmer. Remember the above for tuning pushbuttons. If the high end is peaked on some signal at 1,300 kc., and it is found that a 1,500 kc. station will come in somewhere above 1,500 kc., the high end has then been tuned to the wrong signal. Tune it over, using a signal above 1,300 kc., say 1,350 kc. Never tune the high end of the dial on any signal below 1,300 kc.

Another tip that may help is that in our locality we have a police transmitter on 2,417 kc. and with a set with an I.F. above 400 kc. we can pull them in on the broadcast band. For instance, a good many motorists have sets with an I.F. of 456 kc. and when they tune to 1,505 kc. the oscillator will be generating a frequency of 1,505 kc. + 456 kc. or 1,961 kc., and since the difference between 1,961 kc. and 2,417 kc. is the I.F. of 456 kc. they can tune-in the police any time they choose at 1,505 kc. Of course there is some sort of law against motorists having a receiver that will pull-in the local police, I believe, but if the police don't like it I guess they'll have to move. We were here first.

HOMER C. BUCK,  
Serviceman for Alhambra Radio Co., Detroit, Mich.

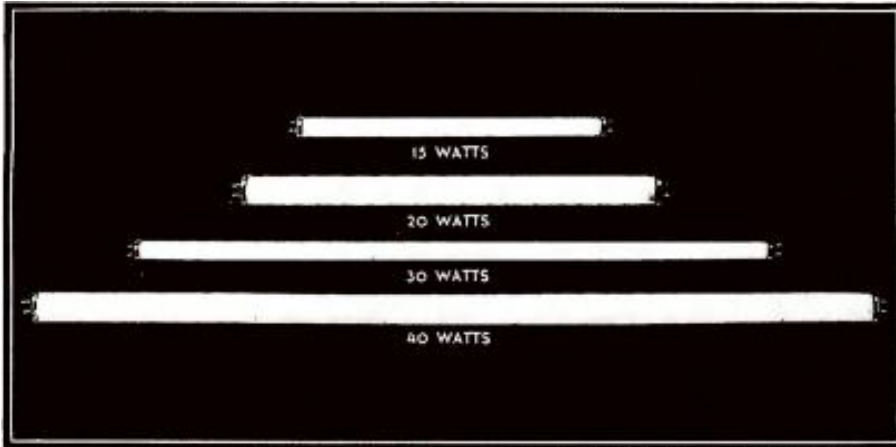

Fig. A. A representative group of fluorescent lamps.

The growing importance of fluorescent lighting, and the fact that many Servicemen are being called upon to install or service this equipment, has made it necessary that Radio-Craft here present the entire technical background of this field. The following article also discusses the problem of radio interference due to such units.



Fig. D. Fluorescent lamp starter and lampholder with starter socket attached.

## FLUORESCENT LIGHTING

### Latest Sideline for Servicemen

THE fluorescent lamp, tubular in shape, contains at each end an electrode in the form of a small coil of wire (see Fig. 1). These electrodes are coated with a material which has the property of freely emitting electrons when heated. Electrons are necessary to carry the arc current which passes through vaporized mercury. Since mercury is a liquid at normal temperatures, a slight amount of argon gas is used to facilitate starting. A base is sealed to each end of the lamp.

and which can be handled effectively during manufacture. The efficiency of fluorescent lamps varies widely between different colors because the various phosphors used do not reach their peak sensitivity at the same point and consequently do not convert equal amounts of ultraviolet energy into visible light. Among the phosphors used at present are:

PHOSPHOR USED	CHARACTERISTIC COLOR OF LIGHT.
Zinc Silicate	Green
Calcium Tungstate	Blue
Cadmium Borate	Pink
Zinc Beryllium Silicate	Bluish White
Magnesium Tungstate	Yellowish White

#### COLORS

Fluorescent powders, called *phosphors*, are coated on the inside of the bulb by a liquid washing process followed by a heat treatment. It is important that a smooth, permanent coating be obtained. This must be even, yet thin, so that the appearance and color of the lamp are satisfactory and there is no excessive absorption of light.

It is necessary to select compounds which remain stable during the life of the lamp

All of the above materials are white when not exposed to ultraviolet radiations. Thus, the unlighted appearance of most fluorescent lamps is identical. Exceptions are the gold and red lamps in which it is necessary to coat the bulb with an appropriate pigment and then add a second or inner coat of fluorescent powder (zinc beryllium silicate and cadmium borate, respectively). The pigmented coat absorbs the radiations which are not desired in the spectrum of the finished lamp.

At the present time, 4 standard sizes of Mazda F lamps are available. These are illustrated in Fig. A.

It is characteristic of all arc lamps that some method must be provided for limiting the current drawn by the discharge. Without a limiting device, the current would rise to a value that would destroy the lamp. This requirement for fluorescent lamps can best be met by a device or auxiliary not incorporated in the lamp itself. The necessity for an auxiliary permits using that device to gain definite advantages in lamp design and performance.

Auxiliary equipment for the present design of fluorescent lamps serves 3 important functions. In order, the equipment:

- (1) Preheats the electrodes to make available a large supply of free electrons.
- (2) Provides a surge of relatively high potential to start the arc between the electrodes.
- (3) Prevents the arc current from increasing beyond the limit set for each size of lamp.

Each of these requirements has several ramifications. In general, many electrical circuits and various types of equipment may



Fig. E. Fluorescent single-lamp ballast.

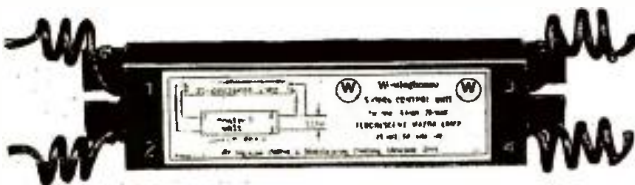

Fig. B. Fluorescent thermal switch control.

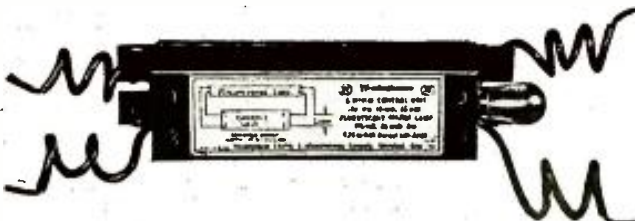

Fig. C. Fluorescent glow switch control.



Fig. F. Bryant fluorescent lampholders. (1) Straight push type; (2) twist-turn type; (3) shallow twist-turn type.



be used to obtain the necessary results. Two broadly accepted types of equipment are in use—*thermal switch* and *glow switch* equipment. The basic difference between the two is in the method of starting the lamp.

For 15- and 20-watt lamps, an open-circuit voltage of at least 100 is required; for 30- and 40-watt lamps, the required open-circuit voltage is about 190. At these voltages or higher levels, ordinary reactances (chokes) or resistances will provide the necessary current limitations. For distribution systems in the 110-125 volt range, a transformer must be part of the auxiliary equipment for 30- and 40-watt lamps. Usually this transformer and the required reactance for current limitation are combined in one unit.

**THERMAL SWITCH CONTROLS**

The usual thermal switch control incorporates in one unit a reactor or high reactance transformer, a thermal switch, and a condenser. One type is illustrated in Fig. 3B, with the circuit used shown in Fig. 2. All parts are enclosed in a metal container which is filled with transformer compound. The purpose of the condenser is to suppress the radio interference that might be caused by opening and closing the switch. It also aids in producing the high-potential surge for starting.

Before starting, the thermal switch illustrated is in a closed position. When voltage is applied, the switch completes a series circuit through the lamp's 2 electrodes and the resulting flow of current heats these electrodes. The switch, however, is made of bimetallic elements and separates upon heating to break the circuit. By this time, from 1 to 2 seconds after voltage is applied, the lamp electrodes have made available an abundance of free electrons. When the switch opens, a high voltage is induced in the reactor. This induced voltage aided by the condenser, is applied across the lamp to start the arc discharge.

The switch is held open by the continuous flow of current through the heater coil. Since the heat is confined, especially if the control is enclosed in a wiring channel or *luminaire*, the thermal switch may remain open an appreciable time if the circuit is interrupted. Thus, instantaneous restarting is not always possible.

**GLOW SWITCH EQUIPMENT**

A later development in starting switches is based on the *negative glow discharge* principle used in neon indicator lamps. At first, this glow switch merely replaced the thermal switch although it was placed externally on the control case rather than within it. Its development, however, suggested certain other changes so that equipment now widely adopted is designed to separate the various requirements of lamp operation.

The switch is enclosed in a small glass bulb and consists of 2 electrodes, one of which is made from a bimetallic strip (Fig. 3). These are separated under normal conditions and form part of a series circuit through the lamp electrodes and the reactance. When voltage is applied, no current flows except as a result of the glow discharge between 2 electrodes of the switch. A heating results which, by the expansion of the bimetallic element, causes the electrodes to touch. This short-circuiting of the switch, which takes 1 or 2 seconds to be completed, allows a substantial flow of current to preheat the lamp electrodes. There is enough residual heat in the switch to keep it closed for a short period of time for the preheating. With the opening of the switch, the resultant high-voltage surge starts

normal lamp operation. If the lamp arc fails to strike, the cycle is repeated.

The switch does not again glow (if the lamp arc is established) since it is so designed that the remaining available electrical potential is insufficient to cause a breakdown between its electrodes. Thus, it consumes no power and if the lamp is turned out, is available for immediate restarting.

**GLOW RELAY CONTROLS**

The first application of the glow switch was in the Glow Relay Control which consists of a reactance and a condenser enclosed in a case with an externally mounted switch. This is pictured in Fig. C, with the circuit used shown in Fig. 4.

**BALLASTS AND STARTERS**

The latest application of the glow switch is designed to separate the switch and condenser from the reactance. The latter is described as a Fluorescent Lamp Ballast (Fig. E) while the switch and condenser are combined in a Fluorescent Lamp Starter. (See Fig. 5.) The Starter consists of a glow switch and condenser which are enclosed in a small aluminum container with contacts which may be easily inserted in a bayonet-type adapter socket, Fig. D. This socket may be an integral part of the standard lampholder attached to it by a single screw or merely connected to it electrically. Usually the Starter is so placed that it projects through a hole in the lamp reflector and becomes as readily replaceable as the lamp itself. The switch provides the lamp electrode preheating and the starting surge; the condenser suppresses radio interference. Two Starters are available for standard fluorescent lamps. The first is used with the 15- and 20-watt lamps. The second is used with the 30- and 40-watt lamps. Since the switch is designed to operate between critical voltage limits, the proper starter must be used for each particular lamp to insure satisfactory starting.

The Ballast is a current-limiting device consisting of a reactor or high reactance transformer enclosed in a metal case. Since the switch has been separated from it, Ballasts are considerably smaller than complete control units.

**2 LAMP BALLASTS**

Figure 6 shows a schematic diagram of a 2-lamp ballast. Certain practical advantages result from the choice of an electrical circuit which combines under one cover the equipment for the control of 2 lamps. Chief among the advantages are improved power factor, decreased stroboscopic effect and reduced auxiliary losses. Simplified and therefore cheaper wiring is another advantage. Each lamp is operated through separate reactors. These reactors are supplied from a common autotransformer for 30- and 40-watt lamps on 118-volt circuits, but no transformer is required for 15- and 20-watt lamps on 118-volt circuits or 30- and 40-watt lamps on 208- or 236-volt circuits. A condenser is connected in series with one lamp and its reactor to give "leading" current. The leading and lagging currents will combine with a resulting line power factor of 95-99%. The currents in the 2 lamps will be approximately 115 degrees out-of-phase. Therefore, the maximum dip in cyclic flicker will occur at different intervals on the cycle and the flicker from the combined light output on the 2 lamps will be minimized.

**STARTING COMPENSATORS**

A starting compensator should be used with all 30- and 40-watt 2-lamp ballasts. One compensator is required for each 2-lamp

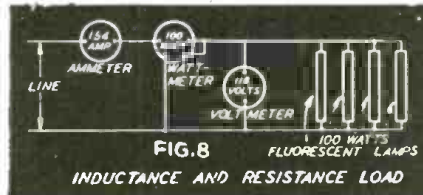
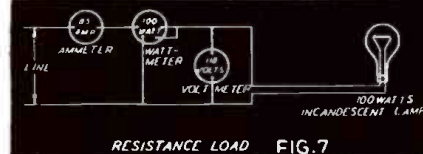
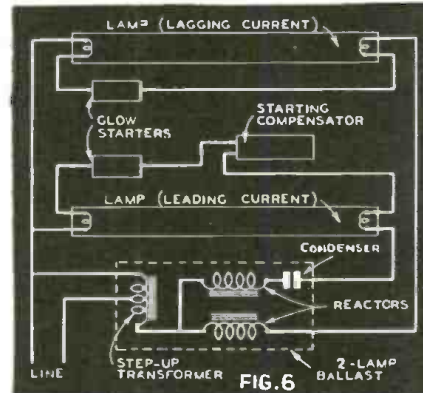
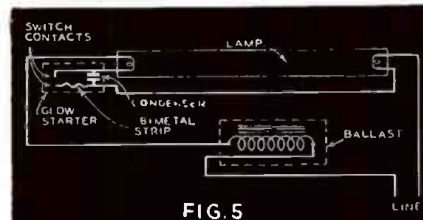
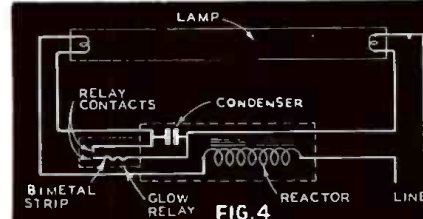
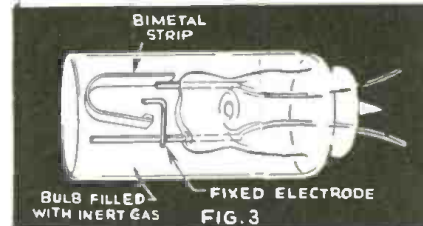
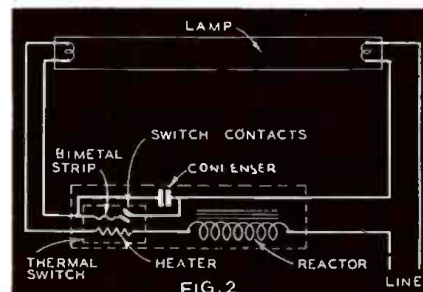
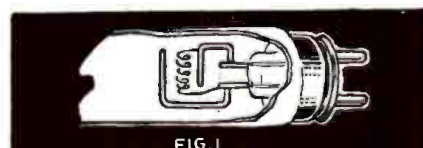

## More Than 25 Proved Sales Promotion Services Help You Sell



**W**HEN you stock Sylvania Radio Tubes, you get the most comprehensive and effective merchandising service that ever helped a dealer to bigger profits.

Look over the partial list below. Many are free. Others are available at satisfying savings. All help you sell.

Write Hygrade Sylvania Corp., Dept. RC11, Emporium, Pa., for samples of these selling aids and full information about the Sylvania way to bigger profits.

### Sylvania Helps . . . That Help You Sell

- |                              |  |
|------------------------------|--|
| 1. Big store displays        | 18. Technical manual                         |
| 2. Window displays           | 19. Tube base charts                         |
| 3. Counter displays          | 20. Price cards                              |
| 4. Electric Clock signs      | 21. Sylvania News Sheets                     |
| 5. Electric Window signs     | 22. Characteristics charts                   |
| 6. Outdoor metal signs       | 23. Interchangeable tube charts              |
| 7. Window cards              | 24. Tube complement books                    |
| 8. Counter cards             | 25. Folding stock hox cabinets               |
| 9. Personalized postal cards | 26. Floor model cabinet                      |
| 10. Imprinted match books    | 27. Large and small service carrying kits    |
| 11. Imprinted tube stickers  | 28. Customer card index files                |
| 12. Business cards           | 29. Shop coats                               |
| 13. Door Knob Hangers        | 30. 3-in-1 business forms                    |
| 14. Newspaper mats           | 31. Job record cards (with customer receipt) |
| 15. Store stationery         |  |
| 16. Bill heads               |  |
| 17. Service hints booklets   |  |

# SYLVANIA

## SET-TESTED RADIO TUBES

Also makers of Hygrade Lamp Bulbs and Miralume Fluorescent Light Fixtures

ballast and it is connected in the starting circuit of the lead lamp, Fig. 6. The compensator functions only while the lamp is starting and is disconnected from the circuit when the glow starter opens. If a compensator is not used, the lead lamp electrodes will be insufficiently heated for starting . . . delaying starting or reducing lamp life.

### LAMP AND CONTROL FAILURES

Under normal operating conditions, the life of switches should be long. For the glow switch, tests have indicated that many years of service may be expected. Reactances and transformers are even more permanent—within practical limits, an almost indefinite life may be expected. Lamps, of course, burn out periodically—in most cases, because of the gradual loss of emissive material from the electrode which accompanies each start of the lamp and, to a lesser extent, each hour of burning.

Occasionally a lamp may fail in such a way that it becomes a "rectifier" and current flows in one direction only. Thus, the reactance will not function properly as a current limiting device. The result may be a burned-out auxiliary, and in the case of thermal controls, the heater coil in the switch usually fails first. Glow switch failures caused by rectified lamps are almost impossible.

### LAMP HOLDERS

Lamp holders are made in several varieties; the most common are shown in Fig. F. The 1st has a "J" shaped slot into which the pins slip and lock. The lamp is released by a sideward pressure. The 2nd is a "twist-turn" type, where the lamp is locked or released by a 90° turn. The 3rd is a shallow twist-turn lampholder, designed for the mounting of 1-in.-dia. lamps where space is at a premium.

### OPERATING CHARACTERISTICS OF FLUORESCENT LAMPS AND AUXILIARIES

Inherently, the fluorescent lamp is different from the incandescent and hence, it is necessary to understand certain characteristics to best judge those fields in which it may be applicable. Obviously, the incandescent lamp has become a basic standard of artificial lighting during the 60 years it has been available and any other light source can best be explained by comparison with it.

The operating characteristics are described in the order listed below:

- |                         |                         |
|-------------------------|-------------------------|
| (1) Voltage             | (9) Lamp Life           |
| (2) Frequency           | (10) Lumen Maintenance  |
| (3) Power Factor        | (11) Temperature        |
| (4) D.C. Operation      | (12) Radio Interference |
| (5) Stroboscopic Effect | (13) Noise              |
| (6) Brightness          | (14) Vibration          |
| (7) Coolness            |                         |
| (8) Color               |                         |

#### (1) VOLTAGE

As with incandescent lamps, variations in supply voltage produce variations in light output. Within reasonable ranges, it may be assumed that a 1% voltage drop decreases the light output 2% while a 1% rise increases it by 2%. Auxiliaries are designed for 3 standard voltages—118, 208 and 236.

In general, best lamp performance is obtained when line voltage is kept within the rating limits of the auxiliaries. At either under- or overvoltage conditions, the lamp electrodes do not operate at their greatest effectiveness. At lower voltage, electrodes do not reach high temperatures and they are overworked, while overvoltage causes excessive heating that quickens the loss of the

emissive material. The result in either case is shortened life accompanied or preceded by excessive blackening. Also, high voltage may overheat the auxiliary while under-voltage may cause uncertain starting.

Occasionally, even though available line voltage is satisfactory, low voltages occur due to momentary overloading of the line, or other emergencies. For most fluorescent lamps, a drop of more than 25 per cent will extinguish the lamp; its period of restarting upon return of voltage will depend on the type of switch in the control circuit. *Fluorescent lamps are, therefore, not satisfactory for "dimmer" service.*

#### (2) FREQUENCY

The current-limiting characteristics of the reactor or high-reactance transformer depend directly upon the power supply frequency for which units are designed. With lower frequencies, the reactance is reduced, and higher current will flow through lamp. Shorter lamp life and overheated auxiliaries will result. With higher frequencies, less current will flow with similar adverse effects on the lamp life and its lumen output.

Auxiliaries must, therefore, be designed specifically for particular frequencies. Equipment designed for 60 cycles should not be used on 50 cycles, nor is the reverse satisfactory. Operation at frequencies less than 50 cycles, seriously increases the problem of stroboscopic effect and, therefore, standard equipment is not available.

#### (3) POWER FACTOR

On alternating current circuits, the statement that volts multiplied by amperes equals watts, holds true only when the voltage and current are "in-phase." Phase differences reduce the *power factor* which equals watts divided by volts times amperes. If watts equal volts times amperes, power factor is 1.0 or 100%.

However, 100% power factor only occurs when the energy consuming device is a pure resistance type (for example, an incandescent lamp) or if a number of different devices neutralize each other. For example, Fig. 7 gives the electrical values in a circuit with an incandescent lamp load. Note that current is 0.85-ampere and power factor is 100%.

However, the reactor or high-reactance transformer used with fluorescent lamps produces a definite "out-of-phase" relation between voltage and current which results in a power factor of about 55%. Fig. 8 shows a 100-watt fluorescent lamp load. Note that current has increased to 1.54 amperes and a power factor of 55%. At a power factor of 55%, current is increased 81% over that for a similar load with 100% power factor.

To the Contractor, the Public Utility and the operator of large installations, power factor is particularly important.

The Contractor finds it necessary to plan the wiring and equipment in excess of what is normally expected by the customer for a specified load, thus creating a barrier to sales. The Public Utility, while it charges for watts registered by a meter, in reality supplies current through a fixed voltage distribution system. Therefore, from generating plant to service entrances, its equipment must be based on uneconomical values when power factors are low. To the owner or operator of a large installation, who pays for the wiring from service switch to outlet, this extra cost and the size of equipment are duplicated.

Since low power factor in fluorescent lamps is primarily a result of the reactance, it may be raised by the addition of a condenser to the circuit. Figure 9 illustrates the



result of adding a condenser to the fluorescent lamp circuit shown in Fig. 8. Note that the current is reduced to 0.94-ampere and the power factor corrected to 90%. The exact rating of the condenser depends on the degree of correction desired and the size and number of lamps to be balanced. Tables are available from manufacturers listing the standard available equipment for small groups of lamps. Other tables are available showing the correct condensers to use to improve power factor of one or more lamps. While a condenser may be placed anywhere in a circuit to improve power factor, its effectiveness in reducing current is only from the point of application to the source of power. Therefore, it should be placed near the lamp. With condensers available which are designed to fit in wireways or in the lighting unit itself, no particular difficulty should be encountered in doing this. Occasionally, other considerations suggest the use of one large condenser for a complete installation but, in this case, all branch circuits and branch circuit equipment must be designed for the larger current accompanying the lower power factor.

The single lamp ballasts with power factor correction and the 2-lamp auxiliary already described are particularly effective since power factor correction is an integral part of each unit. Wiring connections to be made by fixture manufacturers or Electrical Contractors are at a minimum, while, at the same time, the over-all efficiency of the light source is increased through the reduction of electrical losses.

It should be remembered that power factor is only a characteristic of alternating current circuits and does not apply to fluorescent lamps on direct current.

**(4) D.C. OPERATION**

The fluorescent lamp is basically an A.C. lamp and while adaptable to D.C. cannot be expected to give equal performance. All published ratings are based on A.C. operation.

By adding suitable resistances to thermal switch control circuits and to certain other types of circuits, 15- and 20-watt lamps may be operated with reasonable satisfaction, al-

though their life, over-all efficiency and lumen maintenance are adversely affected. With 30- and 40-watt lamps, specific trouble with starting and non-uniform output may be experienced, and their use on D.C. is not recommended.

This trouble is due to the bombardment of electrons in one direction only, which among other things, pushes the heavy mercury molecules to one end of the tube. Sufficient argon may remain around the anode to start the lamp and maintain operation, but the first foot or so of the bulb will remain a dull red indicating the absence of short-wave ultraviolet. Occasionally the available voltage, the bulb temperature, and the angle at which the lamp is burned may combine to eliminate this condition but no assurances can be given.

The glow switch is not suitable for D.C. operation even with a resistance. Usually no harm occurs if this is tried, but the lamp generally will not start. Occasionally the lamp may operate but this is unusual and depends on minor variations of the switch which occur within manufacturing tolerances.

The method of connecting the resistor in circuit is shown in Fig. 10.

**TABLE I**  
**D.C. DATA FOR FLUORESCENT LAMP CONTROLS**

D.C. Lamp Current (Amperes)	External Resistor Required (Ohms*)	D.C. Loss Per Lamp Auxiliary Plus Resistor (Watts)		
		110V.	120V.	110V. 120V.
18"-T8	.30	165	198	18 21
24"-T12	.31	112	144	14 17

\*Based on 32 ohms internal resistance of S#1119200 D.C. Control. Resistors must be used which will handle the lamp current without exceeding the auxiliary temperature.

**(5) STROBOSCOPIC EFFECT**

It is characteristic of all A.C. light sources that there is some variation in light output dependent on the cyclic variations of the current. With incandescent lamps, this is negligible since the filament retains enough heat to compensate for the variation of the current throughout each cycle. With fluorescent lamps, the carry-over of light is dependent wholly on the phosphorescent qualities of the coating. This characteristic of the phosphors varies considerably. The phosphor used in the green lamp has the brightest carry-over, while the phosphor for the blue has the least.

The relative stroboscopic effect of certain lamps and combinations of lamps is given in Table II and indicated on the accompanying oscillograms (Fig. 11). The standard (Westinghouse) 2-lamp ballasts reduce the stroboscopic effect to a point where in ordinary applications it is negligible. Where still further reduction is necessary 3-phase operation of 3 adjacent lamps may be used. The minimizing of stroboscopic effect is an important consideration where moving objects are viewed or where the eye itself is moving rapidly.

**TABLE II**  
**COMPARATIVE STROBOSCOPIC EFFECT OF VARIOUS LAMPS**

LAMP AND METHOD OF OPERATION	RELATIVE STROBOSCOPIC EFFECT*
1. 200-Watt Mazda Incandescent	1
2. 40-Watt Incandescent Lamp	7
3. Green Mazda F—Single Lamp	11
4. White Mazda F—Single Lamp	19

\*Based on ratio of light output during cycle above mean average to total output at mean average.  
NOTE—"Mazda F" are fluorescent lamps.

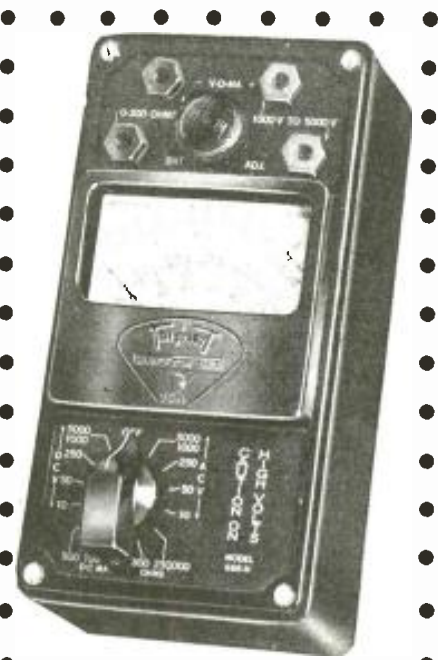
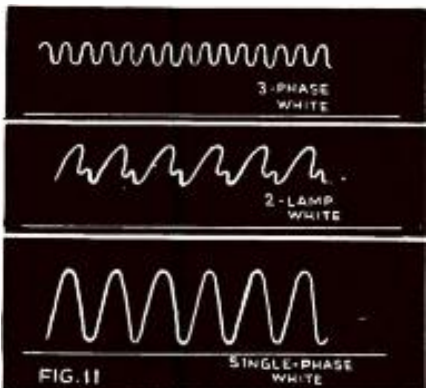
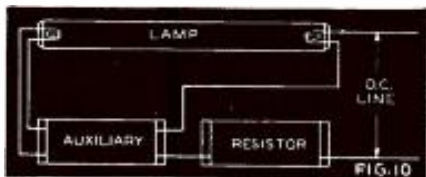
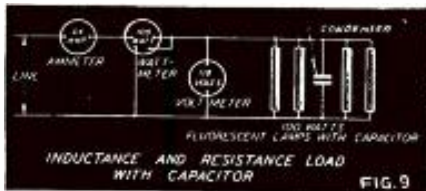

*Pocket Size*  
**TRIPLET**

**AC-DC Volt-Ohm-Milliammeter**  
5000 Volts (Self-Contained)

**MODEL 666-H \$14.50**  
Size: 3-1/16" x 5 7/8" x 2 1/4" Net Price

Model 666-H Volt-Ohm-Milliammeter is a complete pocket-size tester with AC and DC Voltage Ranges to 5000 Volts (self-contained). AC-DC Voltage at 1000 ohms per volt, 0-10-50-250-1000-5000; DC Milliamperes 0-10-100-500; Resistance 0-300 ohms, shunt type circuit; 10 ohms reading at center scale; 0-250,000 ohms, series type circuit; 3700 ohms at center scale. Higher resistance measurements available by using external batteries. Selector switch for all instrument readings. The ideal Pocket Volt-Ohm-Milliammeter for amateurs, radio technicians, industrial engineers, research. Black molded case and panel, completely insulated... with RED\*DOT Lifetime Guaranteed Measuring Instrument... Dealer Net price \$14.50

Model 666... Same as above, but with voltage ranges to 1000 volts... Dealer Net Price \$14.00

**MODEL 1213**

Sockets to test all present day tubes including Bantam Jr., High voltage Series tubes including 117Z6G and 1.4-volt Miniatures. Ballast Tube Continuity Test... Foldex Tube Chart... RED\*DOT Lifetime Guaranteed Instrument... Dealer Net Price... \$22.00



For full cooperation with the National Defense Program, Triplet engineering and production facilities are being rapidly expanded to continue the service and delivery to which our trade is accustomed.

WRITE for CATALOG! Section 161 Harmon Ave.

**THE TRIPLET ELECTRICAL INSTRUMENT CO.**  
Bluffton, Ohio



# SERVICING

LOW PRICE NEVER BOUGHT

BETTER TEST EQUIPMENT Value!

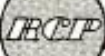

## Model 309 SC TUBE TESTER

Tests all new miniature tubes



Tests all tubes—new miniature, regular receiving, ballast, and tubes with filament voltages up to full line. Indicates noisy tubes that would otherwise test GOOD. Hot interelement short and leakage test between all individual elements. Spare socket provision for future tubes with new base arrangements. Individual tests of each section of full wave rectifiers, duo diodes and all multi-purpose tubes. High sensitivity neon indication. Accurate calibration. Continuously variable line voltage adjustment from 105 to 135 volts by 25 watt power rheostat. De Luxe cord and plug. Double fused line celluloid covered tube charts. Simple and speedy to operate. Net **\$16.95**

Send for new Catalog 124 describing the complete RCP line of 1940 Dependable Test Equipment. Write today.

RADIO CITY PRODUCTS CO., INC.  
88 PARK PLACE • NEW YORK, N. Y.



**FREE!**  
HAMMARLUND  
NEW '40'  
RADIO CATALOG

The latest Hammarlund catalog with complete data, illustrations, drawings and curves on the entire Hammarlund line. Address Department RC-1-1 for your free copy.

HAMMARLUND MFG. CO., INC.  
424-438 West 33rd Street, New York City

Simplest WAY TO REPLACE BALLASTS

4 STANDARD TYPES of Amperite Regulators replace over 200 types of AC-DC Ballast Tubes now in use. . . . Has patented automatic sterling resistor. List \$1.00

WRITE FOR REPLACEMENT CHART "S"  
Amperite Co. 561 Broadway, N. Y. C.

**AMPERITE**

ANY RADIO DIAGRAM

Order circuit diagrams you need at only 25c each. Large, carefully printed schematics supplied with helpful service data. Specify manufacturer and model number. Immediate service.

**25c**

SUPREME PUBLICATIONS 3727 West 13th St., Chicago, Illinois

5. Daylight Mazda F—Single Lamp 21
6. Blue Mazda F—Single Lamp 23
7. White—2-Lamp Ballast 9
8. Daylight—2-Lamp Ballast 10
9. Daylight or White—3 lamps, each on a different phase of a 3-phase circuit 3
10. White—3 Lamps; one on individual ballast, remaining pair on 2-lamp ballast 14
11. Daylight—3 Lamps; one on individual ballast, remaining pair on 2-lamp ballast 15

Stroboscopic effect is not to be confused with "whirl" or extreme flicker which occasionally occurs in a lamp which has not been seasoned properly in manufacture; where some emission material is temporarily in the arc stream; where there is some defect of installation, or where the lamp is near the end of life.

### (6) BRIGHTNESS

The larger surface area due to extended length and the high diffusion of the Mazda F lamp result in low brightness even though the total light output is high. When lamps are exposed, the use of the larger diameter lamp is always suggested unless the lamp is placed in an extremely favorable position. Since angle of viewing, background, and other factors must be considered, no definite recommendation on brightness can be given. The figures in Table III, however, may be compared with a standard enclosing globe which in the normal field of view is considered acceptable if its brightness is about 3 candles per sq. in.

TABLE III -  
BRIGHTNESS OF FLUORESCENT LAMPS  
CANDLES PER SQUARE INCH  
Day-

Size	White	light	Blue	Green	Gold	Pink	Red
18"x1"	4.	3.9	2.5	7.0	3.6	2.3	.4
18"x1½"	3.0	2.6	1.7	4.7	2.4	1.5	.3
24"x1½"	3.6	3.1	1.9	5.3	2.2	1.8	.3
36"x1"	5.5	4.7	3.0	8.7	3.5	2.9	.5
48"x1½"	3.9	3.3	..	..	..	..	..

### (7) COOLNESS

The heat from any light source is in direct ratio to its energy consumption. In terms of heat, 1 watt-hour is equivalent to 3.4 BTU. From this, it is apparent that considerably higher levels of lighting are possible with the more efficient Mazda F lamp with an equal degree of comfort. Naturally, the heat losses of auxiliary equipment must be included with the lamp watts if within the same room or enclosure.

Total heat, however, is not always the important consideration. Quite frequently the form of the heat is of more importance. With a fluorescent lamp, only half of the heat is radiated, the rest being lost by conduction and convection, usually upward. The ratio of heat received by a person or object in close proximity to a fixture may be only one-fourth or less with a fluorescent lamp than with an incandescent lamp, producing the same footcandles.

### (8) COLOR

The word "color" is a very general term and it is important to appreciate its scope when considering fluorescent lamps. For example, the radiated energy of the green lamp is confined to a narrow band and it may truly be called a source of green light. On the other hand, the blue lamp covers a much broader range. While blue in appearance, it might be more critically termed a "pastel blue", implying that there are

enough other radiations to add a synthetic white to the blue. This is obviously true for the pink lamp; pink is actually "pastel red". This distinction of color is seldom important except where special effects are desired; as when colored lamps are being considered for general lighting of interiors.

The white lamp is not an exact match for the incandescent source, nor is the daylight lamp an exact reproduction of natural daylight. Yet, under most conditions, the eye can detect little difference from a seeing standpoint. Neither lamp is suitable for critical color matching or exacting color discrimination.

The primary differences between fluorescent lamps and natural light are (1) the lack of a deep red and (2) the presence of the spectral lines of a normal mercury discharge. The former, unobtainable at present from phosphors of satisfactory efficiency, is sometimes of importance where deep reds, such as in raw meats, must be viewed. The second difference, noticeable by a slight yellow-green distortion of certain colors, becomes important where certain colors are used for interior decoration. Unless previously used, a proposed color scheme should be examined with the light under which it is to be used. In all cases where color appearance is important, the use of fluorescent lamps should be carefully analyzed.

### (9) LAMP LIFE

The rated average laboratory life of the (Westinghouse Mazda F) fluorescent lamp is 2,500 hours. This is the life obtained when lamps are tested on approved auxiliary equipment at its rated line voltage and frequency.

Since very frequent starting will affect the life adversely, fluorescent lamps are not recommended for services of a type similar to the flashing of lamps in signs.

### (10) LUMEN MAINTENANCE

The light output of a fluorescent lamp decreases somewhat during its life. The depreciation in efficiency at 70% of rated life of the average lamp is about 15%. It should be noted, however, that during the first 100 hours of life, the drop in light output is more rapid than during subsequent burning hours. It is for this reason that the published "initial" lamp-lumen and lumen-per-watt values apply at the 100-hour point. This conservative basis of lamp rating explains the somewhat higher levels of light output often experienced with a new installation.

The snow white appearance of the standard phosphors is gradually blemished by blackening which is relatively insignificant from an output standpoint. This is emphasized by the non-uniformity of the blackening, which tends to collect opposite or near the cathodes. Noticeable blackening prior to 750 hours is generally caused by improper operating conditions (voltage, bulb temperature, choke characteristics, starter defects, etc.). Trouble from such conditions can be found by investigation and must be corrected for best service.

### (11) TEMPERATURE

Lumen output values of the (Mazda F) fluorescent lamp are obtained when measured at 80° F. ambient temperature. This would indicate a bulb wall temperature slightly higher (100°-120° F.), within which range lumen output is approximately unchanged. The light output will decrease about 1% for each one degree drop in bulb temperature below 100° F. While this is not absolutely accurate, it is close enough for field estimates. While the arc will usually

(Continued on page 411)



*Read in this article how a wide-awake Serviceman has capitalized on the fact that the new low-"B"-drain tubes with 1.4-V. filaments afford improved operation over the 2-V. types in many existing battery-operated radio sets.*

Illustrated at left are the complete steps necessary to convert a Philco type 38-38, in about 1 hour, from 2-V. to 1.4-V. operation.

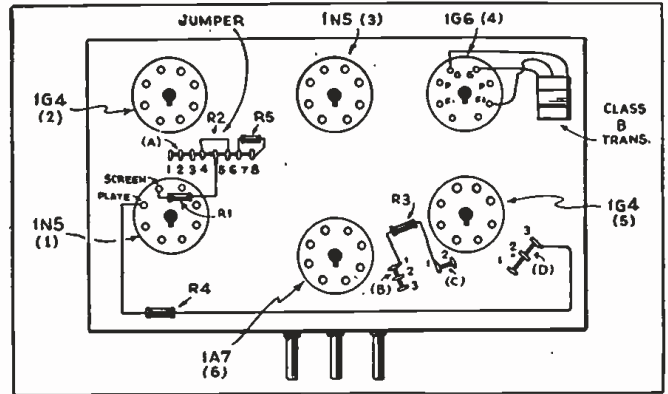

# CONVERTING 2-VOLT SETS TO 1.4 VOLTS

KEN MOORE, JR.

EVER since the conception of radio it has been the privilege of the radio Serviceman to endeavor to keep the radio sets in his community working at top efficiency. This at times has consisted not only in repairing sets because of natural breakdowns, but also modernization of older equipment, in order that it might embody insofar as possible refinements that came into being after said equipment was already in use. This condition arises mainly from the fact that no other industry has ever made so many improvements in so short a space of time as has radio.

In some cases the cost is prohibitive, in others the changes are impractical. However, when such changes are practical, and when the cost is within reason, it is to the interest of the Serviceman that he avail himself of the opportunity, for in this way he can build up customer confidence and goodwill better than any other way that the writer has been able to find.

All experienced Servicemen will readily admit that the general public in many localities has had good reason to look upon the profession with a sad and distrustful eye, as there has been, as well as in many other lines of a comparable nature, quite a few fellows whose methods were very questionable. This makes it unduly hard on the honest Serviceman, and the writer is very thankful that this state of affairs is now much better, as the common pliers-and-screwdriver men of the early years have faded out of the picture, as they can not cope with the complicated circuits of the modern allwave sets.

All of the older Servicemen remember the early conversion jobs brought about by the change from the old 201A days to the early electric sets. Results achieved here were not always satisfactory.

## ENTER THE 2-V. AND 1.4-V. SETS

**2-Volt Sets.**—Then came the 2-volt set for rural use. This was quite an improvement over anything yet offered, and looked like perfection in person, to those who had been used to the expense and inconvenience of the storage battery days. Very little conversion was attempted at this time as these 2-volt sets also ushered-in the super. that had not been available up to this time (except in very expensive or custom-built sets). This made it undesirable to do other than to get a new set.

**1.4-Volt Sets.**—Next we have the 1.4-volt set that is superseding the 2-volt set, and it has just about as many advantages over it, as it had, in turn, over its predecessors, es-

pecially in regard to economy of operation. However, worthwhile circuit changes are notable by their absence. Hence we have the unique case of a modern radio being obsolete because of expense of operation. In short, we now have many comparatively new 2-V. sets in use, or traded-in to some dealer, because of the simple fact that they cost too much to operate.

This new series of tubes now has a counterpart for almost every tube that is in the 2-V. class. (A glance at a manual of operating characteristics will show you how true this is.) However you will find that some of the types that you would consider not interchangeable, do interchange, and the writer has yet to see a set that did not actually perform better after conversion, than it did as a 2-V. set! This is due to the improved operating characteristics of the new tubes; as for example: a type 1N5 tube has an amplification factor of 1,160, which compares with G10 for a type 32, and 360 for a 34. Thus it is only natural that there should be a decided improvement in the all-around performance of the conversion job. (If the reader will please excuse the personal pronoun, I will continue in the first-person.)

## "HOW I STARTED"

I began to do this work upon the insistence of my local radio dealer. I serviced sets, but did not sell them; he had a great many 2-V. sets on hand, and found that he could not sell them, as few wanted to buy a radio receiver using from 3 to 7 batteries, when in all probability their neighbor had a set that used only 1. So he insisted that I do something to help him out in regard to what was fast becoming a serious proposition, as he could not offer much for a "radio" that had no resale value, especially in view of the fact that most of the sets he was selling retailed at only \$30, or only slightly higher, this being a most popular price range.

**Philco.**—So I took a Philco model 38-38 (see illustration) out to the shop and began to see what could be done about the matter. This is a 6-tube set, and is a splendid performer as a 2-volt set.

After consulting a manual of tube characteristics, I saw that the set should perform in some manner, without any circuit changes at all. Of course, as preliminary work, I changed the battery cable to accommodate a 1.4-volt battery plug, doing this by placing the 67½- and 135-V. lead on the 90-V. terminal of the new plug. All "C" wires were attached to the "B—", so

there would be no grid bias on the new tubes, as they are usually operated with "O" grid bias. The original tube complement of this set was as follows: 2—1H4s, 1—1C7, 1—1J6, 1—1E5, 1—1D5. To replace these tubes, I used these types, respectively: 2—1G4s, 1—1A7, 1—1G6, and 2—1N5s.

The set did operate, and fairly well at that, without even realignment of the circuits. There was a slight tendency toward circuit oscillation, but slight additional bypassing in the screen-grid circuit stopped that. I then made other slight changes that are shown on the drawing reproduced here. I made all these changes before I attempted realignment of the I.F. and R.F. circuits. I then found that I now had a set that actually out-performed its previous good record, in all except power output, and even here the ear could not detect this fact, as the human ear is not very good at such "measurements."

A practical "air test", though, revealed that it was much more sensitive, and exhibited better daytime reception characteristics; and, at night, selectivity was very much better. However, I was particularly well pleased with the fact that the "B" drain had been reduced to 14 ma. with the peaks being almost unnoticeable; the "A" drain, was of course, only 370 ma. (This compares very favorably with the commercial 4- or 5-tube, 1.4-V. set.) This set has been in use for many months, now, and the owner is extremely well pleased.

**Sentinel.**—I next decided to attempt an older model. I selected a 4-tube Sentinel, model 80B (or 167S). This is a 4-tube set with a ballast tube if used with 3-volt dry "A" battery. It has these tubes: 1C6, 34, 33, 1F6. I used these to replace: 1A7, 1N5, 1Q5, 1H5.

I might mention here that it is not only wise to see that the set is working properly in its original state, but also, to always change over the oscillator stage first. In this way any failure of this stage can be corrected before proceeding farther.

The circuit of a 1A6 or 1C6 will work perfectly in most cases when wired-up to fit a 1A7, but in case you find trouble here, add about 5 or 6 turns to the primary of the oscillator coil and this will remedy the trouble.

Up to the time of this writing there has been no duodiode-triode 1.4-V. tube announced, but as in the case above, both diodes are tied together so that therefore a 1H5 replaces the 1F6. This will be found true in many cases, but even if all 3 sections of a triple-purpose tube are used



The Outstanding Tube Tester Value . . . Checks all types tubes including Loctals, Bantam Jr., 1.4 volt Miniatures, Gaseous Rectifier, Ballast, High Voltage Series, etc. Filament Voltages from 1.1 to 110 volts. Direct Reading GOOD-BAD Meter Scale. Professional-appearing case with accessory compartment large enough for carrying Model 739 AC-DC Pocket Volt-Ohm-Milliammeter, thereby giving the serviceman complete testing facilities for calls in the field. . . . Model 432-A with compartment, Dealer Net Price . . . \$18.85. Model 432-A in case less compartment . . . \$17.85. Model 739, Dealer Net Price . . . \$9.90.

WRITE FOR CATALOG—Section 161 College Drive

**READRITE METER WORKS, Bluffton, Ohio**

**EVERYTHING IN RADIO**

**RADIO**

THIS BIG BOOK SERVES YOUR ENTIRE NEEDS. IT INCLUDES SETS, PARTS AND SUPPLIES, PUBLIC ADDRESS, AMATEUR EQUIPMENT, TESTERS, KITS, FLUORESCENT LIGHTING. NATIONALLY KNOWN FAVORITES AT LOWEST POSSIBLE PRICES. WRITE TODAY FOR YOUR COPY OF THIS

**BIG FREE CATALOG**

**BURSTEIN-APPLEBEE COMPANY**  
1012-14 MCGEE STREET, KANSAS CITY, MISSOURI

*For better  
Typewriters*

**WOODSTOCK TYPEWRITERS**

**SOLAR RED-CAPS**  
Smaller Diameter Dry Electrolytics

**SPEED Servicing**

Write for Catalog

**SOLAR MFG. CORP. Bayonne, New Jersey**

separately, there is still another solution that is discussed a bit farther on in this article.

**Crosley.**—Some sets will work with almost no circuit change at all. A good example of this class was a Crosley "Fiver," model 527, using a 1J5, 1C7, 1H6, 1D5 and 1H4. To replace, I used: 1Q5, 1A7, 1H5, 1N5 and 1G4. Except for changing battery connections, the only change in the circuit was to change the grid connection of the 1H6 from the socket base to the top of the 1H5 tube. Again, performance was all that could be desired.

**Other Sets.**—I also changed over, and was well pleased with the results, many others such as the older Philcos, Airlines, Silvertones, etc.

I might add, that the Serviceman should be very careful to check for leakage all condensers in the older sets, as this is a common ailment with them. I have been well pleased with what I have been able to do in these conversions, and most important of all, my customers have also been very appreciative. Things like this certainly do not hurt my prestige: A customer of mine has a brother who lives quite some distance away, and my customer told him to have his set converted. But the local radio repairman in his locality told him it could not be done. Is it any wonder that I am getting not only his work, now, but also other radio repair work from this locality, that is much too far away from me to have come into my shop except for the above and similar incidences?

**SPECIAL PROBLEMS**

It is important to remember that many sets have some means of regulating the filament current, either automatically by a ballast tube, or manually by a variable resistor. These must be disposed of. Also there are numerous ways of obtaining biasing current, such as biasing cells, from the filament or "B" voltage arrangement, or "C" batteries. These must also be properly taken care of.

I use a 2-V. storage cell in my work of this nature, using it directly on the filament of the set as a 2-volter, and using a variable resistance and voltmeter to cut same down to 1.4 volts for the new tubes. When you have placed your 1A7 tube in the set, leave the remaining 2-volt tubes in place and turn the set on. It will now play in a somewhat weakened fashion. You may then change other tubes in any order desired, noting that the set will begin to improve, step-by-step, as the old tubes go out one by one. Some commercial sets of the 1.4-V. class are being used with bias cells to give some bias, this year, so if your set has these in it, it might be well to try the receiver with or without, and use whichever arrangement results in improvement, even though the tube manufacturers list the tubes to be used with zero grid bias.

I am listing the most common types of the 2 classes, with their corresponding replacement. Of course it is understood that the older types must have octal sockets to replace existing sockets, so the new types can be used. I have found that variations in characteristics values of 20% or more interchange very nicely.

Original 2-V. Tubes	New 1.4-V. Equivalents
1C6, 1A7, 1A6	1A7
1H6, 1F6, 1B5/25S	1H5
1D5, 34, 32, 1B4, 1A4, 1E5	1N5, 1P5
1H4, 30	1G4, 1E4
1J5, 33	1Q5
1J6, 19	1G6
1F4, 1F5	1A5
1G5	1C5
(See text next column.)	1N6

If your set uses 2-type 30 tubes or 1H4 tubes in class B output, you can lessen the number of tubes in the set, by using a 1G6 to replace them. Should it use a 30-type tube for an oscillator, try using a 1E4 to replace it, as this is a real fine oscillator.

If you have a set that uses a triple-purpose tube and all 3 sections are used separately, then use a 1H5 to replace it, and then employ a 1N6 as your output tube, as it has a diode section built-in, and so arranged that it is ideal to drive its pentode output section, that is almost identical with the regular 1A5. Thus you can achieve the same results as the circuits were designed for.

Should your 2-V. pentode output not have the load characteristics of the 1N6, then you can replace the output transformer very economically, as there is a replacement transformer that lists for only 65 cents (see radio mailorder catalogs).

The above will give a good idea how practical it is to convert most of the 2-V. sets now in use; and show that the procedure is also economical.

**COSTS**

The cost of this work is very reasonable. In some cases it can actually be done for less than the amount required to outfit the set with the batteries it normally uses, of the heavy-duty type!

The Philco 38-38 will cost as follows (prices are list): tubes, \$7; battery, \$3.95; labor, \$3, or a total of \$13.95. Heavy-duty batteries cost from \$13.95 to \$16.25, so the saving is readily apparent. And it is well to note that this heavy-duty set of batteries will hardly give the same hours of service as will the new battery, it being necessary to replace the "B" batteries after about 600 hours of service, while the new battery will give about 625 to 675 hours' service. I am in position to do this work cheaper than those located in the high-rent districts, perhaps, but you can raise my prices, and still be very much in reason. Also by stocking your own tubes and batteries you can make an additional profit there that will amount to a nice sum.

It has always been my policy to not only do all the regular repair work, but to try to do all that my customer expects of me. All contacts that you make will be of mutual benefit, and will add materially to the income.

I am showing on the diagram the complete steps that are needed to convert a Philco 38-38. This will suffice to show how simple it is. Time consumed: about 1 hour.

**FEATURE ARTICLES IN THE JANUARY ISSUE OF RADIO & TELEVISION**

- Radio—the Army—and YOU  
Lt. Myron F. Eddy, U.S.N., Ret.
- The R. & T. Videophone, Part 3  
Ricardo Muniz & S. Morton Decker
- A Directional Radio Beam Indicator  
Leon M. Lefingwell
- 112 Megacycle (2½ meters) Airplane Radio Set . . . . . A. D. Brandon
- A Home-Made Finch Type Facsimile Recorder . . . . . Carl Helber
- A Compact Kilowatt Transmitter  
Larry LeKashman, W2IOP
- Radio Patent Digest
- Question Box
- Radio "Hook-ups" Department
- Experimental Radio



Radio Service Data Sheet

RCA VICTOR MODEL U-50 RADIO-PHONOGRAPH (Chassis No. RC-414C)

5-Tube Superhet.; 3 Bands (540 to 1,720 kc., 2.3 to 7 mc. and 7 to 22 mc.); Portable Radio-Phono Combination; Crystal Pickup; Mercury Switch for Automatic Starting and Stopping of Phono Motor; A.V.C.; Automatic Bass Compensation; Single-ended Tubes; Power Output (max.) 3.5 W.; Power Consumption, 105 W.

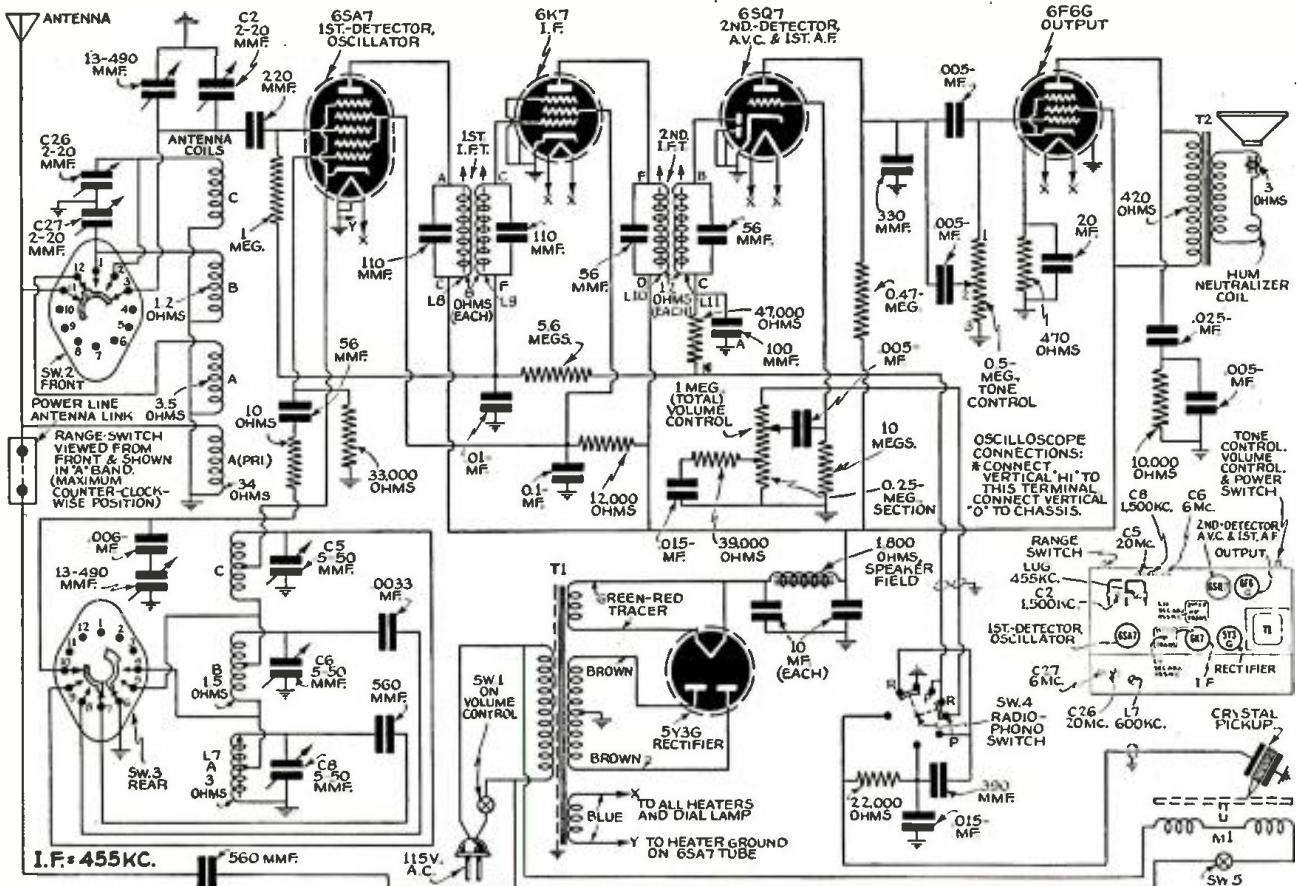

Schematic diagram of RCA Victor model U-50 (chassis No. RC-414C) portable radio-phonograph; and sketch showing locations of alignment trimmers.

ALIGNMENT PROCEDURE

**Cathode-Ray Alignment**—Is the preferable method. Connections for the oscilloscope are shown in the chassis drawing.

**Output Meter Alignment**—If this method is used, connect the meter across the voice coil, and turn the receiver volume control to maximum.

**Test-Oscillator**—For all alignment operations, connect the low side of the test-oscillator to the receiver chassis, and keep the output as low as possible to avoid A.V.C. action.

**Calibration Scale on Indicator-Drive-Cord Drum**—In most cases it will not be necessary to remove the chassis from the dial scale for alignment, allowing the dial scale to be used for calibration. However, if alignment is made with the receiver chassis removed, the calibration scale attached to the rear of the drum which is mounted on the front shaft of the gang-condenser must be used. The setting of the gang-condenser is read on this scale, which is calibrated in degrees. The correct setting of the gang in degrees, for each alignment frequency, is given in the alignment table.

As the first step in R.F. alignment, check the position of the drum. The 135° mark on the drum scale must be vertical, and directly under the center of the gang-condenser shaft when the plates are fully meshed. The drum is held in place by one set-screw, which must be securely tightened when the drum is in the correct position.

**Pointer for Calibration Scale**—Improve a pointer for the calibration scale by fastening a piece of wire to the gang-condenser frame, and bend the wire so that it points to the 0° mark on the calibration scale when the plates are fully meshed.

**Dial-Indicator Adjustment**—After fastening the chassis in the cabinet, attach the dial indicator to the drive cable with indicator at

the 530 kc. mark, and kang condenser fully meshed. The indicator has a spring clip for attachment to the cable.

The corresponding position of the dial indicator for any setting of the calibration scale, shown at right, is determined by drawing a fine line from this point on the bottom calibration to the top calibration scale. For example, 33° on this scale equals about 7.9 mc. on the "C" band and 600 kc. on the "A" band, etc.

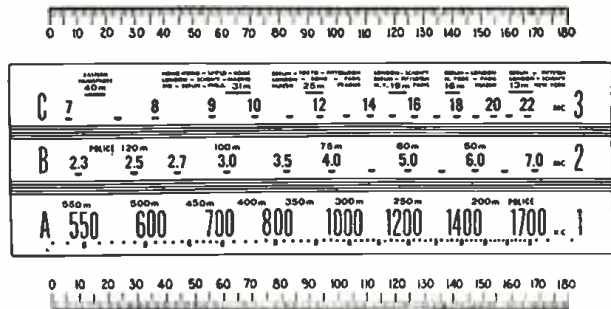

Receiver dial and corresponding 0 to 180 deg. calibration scales.

Steps	Connect the high side of test-osc. to—	Tune test-osc. to—	Turn receiver dial to—	Adjust the following for max. peak output
1	6K7 I.F. grid cap. in series with .01-mf.	455 kc.	"A" Band quiet point between 550-750 kc.	L10 and L11 (2nd I.F. trans.)
2	Tuning condenser stator (osc.) in series with .01-mf.**	455 kc.		L8 and L9 (1st I.F. trans.)
3	Antenna lead in series with 200 muf.	600 kc.	600 kc. (33°) "A" Band	L7†
4		1,500 kc.	1,500 kc. (152.4°) "A" Band	C2 (ant.) C8 (osc.)
5				Repeat steps 3 and 4
6	Antenna lead in series with 100 ohms	20 mc.	20 mc. (155.4°) "C" Band	C5 (osc.)* C26 (ant.)
7		6 mc.	6 mc. (149°) "B" Band	C6 (osc.)* C27 (ant.)
8	Antenna lead in series with 200 muf.	1,500 kc.	1,500 kc. (152.4°) "A" Band	C3 (osc.)

\*Use minimum capacity peak if 2 peaks can be obtained.  
†Rock gang condenser slightly while adjusting L7.  
\*\*Make test-oscillator connection to lug on tuning condenser stator (oscillator section) in series with .01-mf. condenser.  
Note.—Oscillator tracks 455 kc. above signal on all bands.



RCA Victor model U-50 portable radio-phonograph.

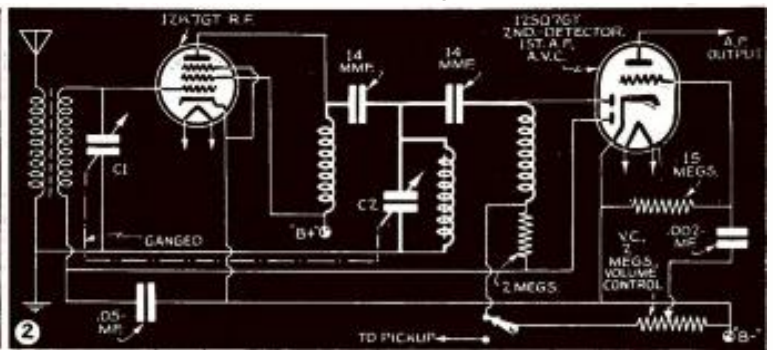
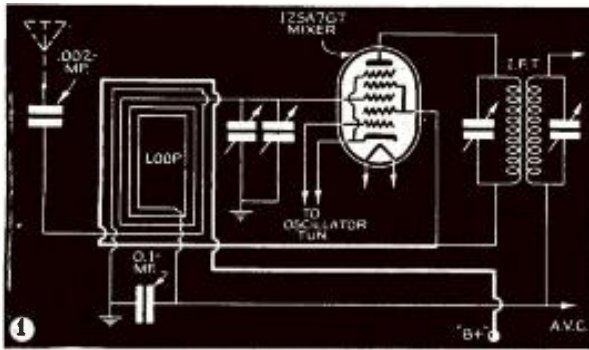

# NEW CIRCUITS IN MODERN RADIO RECEIVERS

*In this series, a well-known technician analyzes each new improvement in radio receiver circuits. A veritable compendium of modern radio engineering developments.*

F. L. SPRAYBERRY

No. 40



(FIG. 1.) REGENERATION USED IN R.F. CIRCUIT TO IMPROVE GAIN AND SHARPEN R.F. TUNING

EMERSON MODELS EL-360, 361, 362, 373 & EP-367, 375 & 381.—A predetermined amount of feedback energy from the mixer plate circuit to the mixer control-grid is introduced into the circuit to improve the R.F. selectivity, and hence, reduce the image response and also add R.F. gain to the circuit.

By reason of the plate-circuit loop coupled to the loop antenna, as shown in Fig. 1, a maximum amount of feedback somewhat below the critical point of oscillation of the mixer R.F. section is obtained. While the degree of regeneration varies within the broadcast band, it is never excessive nor too low to have the desired effect in the receiver. The 1st I.F. primary acts as a high-pass filter to R.F., and hence, has little opposition to the R.F. feedback component.

(FIG. 2.) SHUNT-IMPEDANCE-COUPLED T.R.F. CIRCUIT

SILVERTONE (SEARS, ROEBUCK & CO.) MODEL 5701.—This circuit arrangement permits a common condenser gang ground, and an A.V.C.-phono connection to be made in the conventional manner in a T.R.F. set.

Usually the detector tuning condenser re-

quiring an isolating unit to close the tuned circuit is not suitable for switching to phonograph operation without a switching system which makes certain circuit changes. These circuit changes being made in high-frequency circuits have the usual limitations. This problem has been solved for T.R.F. sets by the circuit shown in Fig. 2.

(FIG. 3.) DOUBLE-SECTION TONE CONTROL

PHILCO MODEL 41-250 & 41-255.—A 2-element resistance in one unit makes possible independent and complete control of tone both in the regular selective bypass method and by modifying the bass compensator circuit.

Each of these elements has a value suited to its own circuit and for the most complete coverage of the range of both the regular tone control and the bass compensator. Moreover, according to the circuit, Fig. 3, the range of one is completed before the other starts into action. With only one resistor of any value the total range of both would be limited and some sacrifice of each would have to be made for the other. The bass compensator requires a much larger resistance value for full variable range than the tone control.

(FIG. 4.) SHOULDER STRAP ON "PERSONAL" RADIO SET USED AS LOOP ANTENNA

PHILCO MODEL PT. 89.—By wiring the carrying shoulder strap for use as a loop antenna in this portable radio, the area of the loop while in use is greatly increased, thus improving the signal pick-up.

Because of the fact that the loop is flexible and may assume different shapes, it is not practicable to tune it. Its inductance changes with its shape. Also, to prevent it from having serious detuning effect on the input tuned circuits of the set, it is loosely coupled to the input. Inductive coupling is necessary to prevent capacity effects of the loop which will vary widely in use. The loop and input circuit are shown in Fig. 4.

(FIG. 5.) IMPROVED RADIO-PHONO SWITCHING SYSTEM

GENERAL ELECTRIC MODEL J-71. In the Radio-Phono switching circuit is included the volume control and the I.F. filter so that for radio reception the circuit will be normal while for phonograph reproduction the diode-return is directly grounded and the I.F. filter is in the phonograph input to the volume control.

In the first place this position of the I.F.

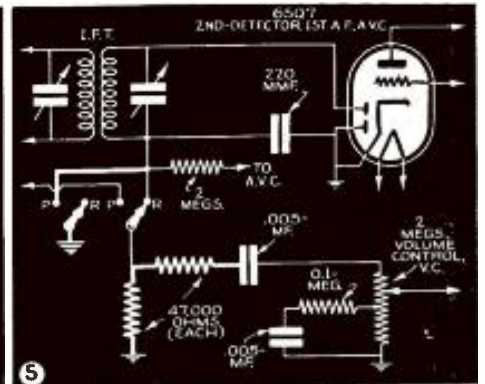
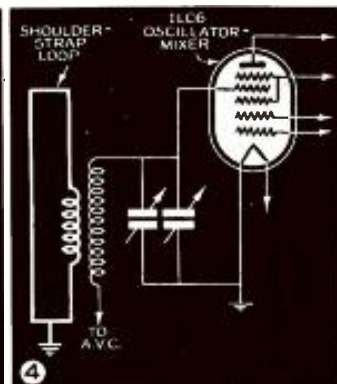
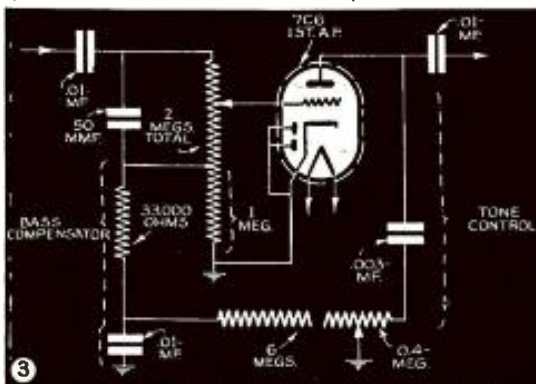



filter, as in Fig. 5, provides an impact filter so that no matter where the volume control is set the switching operation may be completely silent. Moreover, there is no audio drop across the 47,000-ohm I.F. filter section in the phono position arising from reception. Because no A.F. is developed, there is no chance of any audio pick-up from this source due to capacity effects.

## FLUORESCENT LIGHTING

(Continued from page 406)

strike at temperatures as low as zero degrees F., early blackening and short life may result from low-temperature operation. It must be emphasized that the above statements concern the temperature of the bulb. While all fluorescent lamps are of low watts rating and relatively cool, there is obviously some generation of heat.

Thus, the bulb may be considerably warmer than its surroundings unless cooled by moving air. The protection afforded by a reflector is often sufficient to trap enough heat to assure satisfactory lamp operation even at freezing temperatures. Better results will be achieved by the use of a cover glass for the reflector or some other means of directly protecting the bulb. Auxiliary heating may be employed (resistance coils or incandescent lamps in the same enclosure) but this should be necessary only when it is imperative to have maximum light output at all times or when extremely low temperatures are continuous.

Above 120° F., the light output also drops but not nearly as quickly as with low temperatures. Up to 200° F., an approximation for field use would be a 1% light decrease for a 3 deg. bulb temperature increase. Temperatures above 200° F. are rarely encountered where fluorescent lamps are considered applicable.

The change in light output is due largely to the change in character of the arc discharge which alters the relative amount of ultraviolet generated and thereby affects the subsequent production of light by fluorescence.

Because of the changes in arc characteristics at low temperatures, fluorescent lamps may not operate satisfactorily on circuits controlled by glow relays. At temperatures below freezing, the high voltage existing across the lamp may cause the switch to alternately open and close which prevents the arc from being established.

### {12} RADIO INTERFERENCE

The fluorescent lamp, since it is an arc discharge, may cause radio interference. The exact nature of this interference is being actively studied and it is reasonable to assume that some of the effects will be eliminated gradually. Well grounded fixtures, short leads from lamp to reactance, metal mounting for sockets, all aid in producing a trouble-free installation.

Interference does not seem to be cumulative. That is, 10 lamps would cause only slightly more than 1 lamp. By outside antennas or other means, increased ratio of signal to interference can lessen the effect of any disturbance. Under certain conditions, a condenser from each side of the line to ground at the receiver may be needed although most of the better grade radio sets are protected in this way. In general no trouble will be met if the set is 8 ft. or more from the nearest lamp.

### {13} NOISE

With any reactor or high-reactance transformer, there are certain to be some audible frequencies generated by the alternating magnetic force pulling on the iron laminations. Fluorescent auxiliaries are now de-

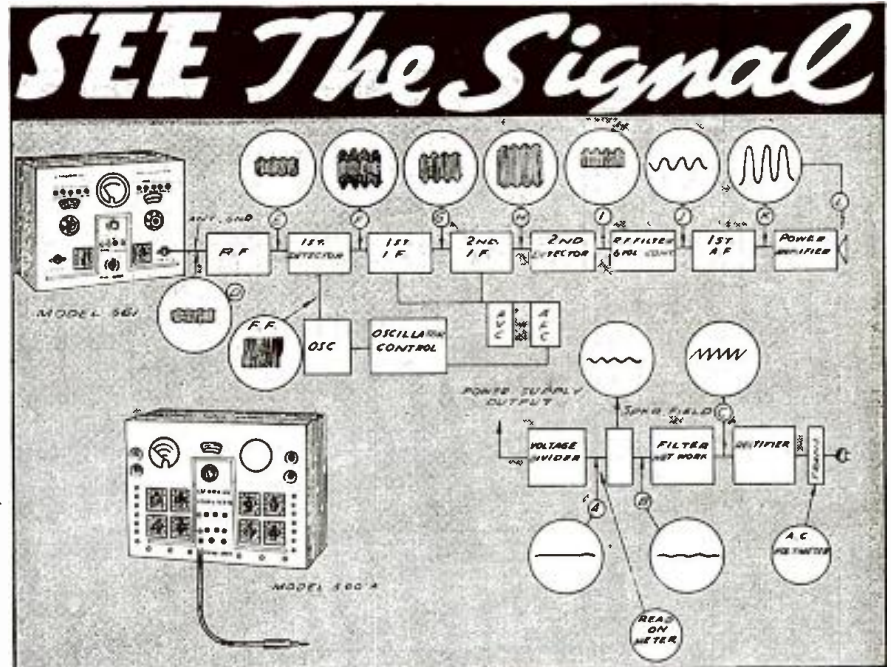

# VEDOLYZER MODEL 560-A

Not only see the signal but see the QUALITY.

What happens to the signal between the antenna and speaker of a typical superheterodyne? Does it pass the RF, Mixer and Intermediate stages free of distortion? Can you actually see the QUALITY of the signal as it is converted and amplified through the successive stages?

Can you check the QUALITY of the generator signal at the antenna post (D)? Is it amplified free of distortion to the input of the first detector (E)? Did the first detector produce a modulated signal with similar characteristics of the supply signal (F)? In addition to the gain of the I.F. stages, can you immediately see distortion which can be caused by defective tubes and open by-pass condensers? Do these stages have excessive hum, possibly originating at the first detector as modulation hum, or is it introduced by a defective component of the power supply (G, H, and I)? Is the second detector rectifying or is it introducing distortion caused by a defective tube which will not show up

on a standard tube tester or signal tracer which indicates amplitude only? Do you have a smooth sinusoidal waveform at the outputs of the audio amplifiers such as J, K, and L, or is it ragged, indicating tube or hum distortion which can be readily located by a dynamic signal analyzer which will indicate the condition or QUALITY of the signal as well as the gain or losses?

The Model 560-A Vedolyzer is not a mere signal tracer, it is a complete Dynamic Analyzer which will show you what the signal looks like in addition to indicating the existence, absence, gain or amplitude.

Testing for hum, distortion and any of those troubles which require more than an ordinary signal tracer is just part of the routine for the Vedolyzer. Think of the requirements you will have to meet before you purchase dynamic testing apparatus. You will need more than a signal tracer to determine the QUALITY of the signal—The Vedolyzer is a revelation in meeting the full requirements of the modern service laboratory—an instrument for COMPLETE DYNAMIC ANALYSIS.



For full information on Model 560-A and complete Catalog of new, 1941 SUPREME test equipment, write  
**SUPREME INSTRUMENTS CORP.**  
 DEPT. RC-11  
 GREENWOOD, MISSISSIPPI

signed to minimize this inherent "hum". Frequently a hum is changed to noise by amplification due to the mounting of the auxiliary on some resonating surface. Good installation practice calls for (1) stiffening of long troughs; (2) sound deadening such surfaces where stiffening is difficult; and (3) fastening auxiliaries by screws with sound insulating sleeves, washers, and pads to prevent the transmission of hum.

It is probable that hum will never be completely eliminated from some types of auxiliaries because of commercial and economic limitations. However, certain well-made auxiliaries, particularly of the 2-lamp type, are now available in which hum is only audible when the unit is close to the ear.

Hum is usually not objectionable in factory spaces or other areas where noise always prevails to a certain degree. However,

in quiet rooms, or when the light source operates close to the user, the hum may become annoying and it may be necessary to locate auxiliaries at a remote point or in sound-proof cases. Hum or noise is additive, so that a single unit which may not be objectionable might be combined with sufficient other units to require special attention.

### {14} VIBRATION

While no doubt extreme vibration will have a damaging effect on the life of fluorescent lamps, they appear to be able to withstand more than the ordinary conditions encountered in lighting service. The arc itself is unaffected.

This article has been prepared from data supplied by courtesy of Westinghouse Electric & Mfg. Co.

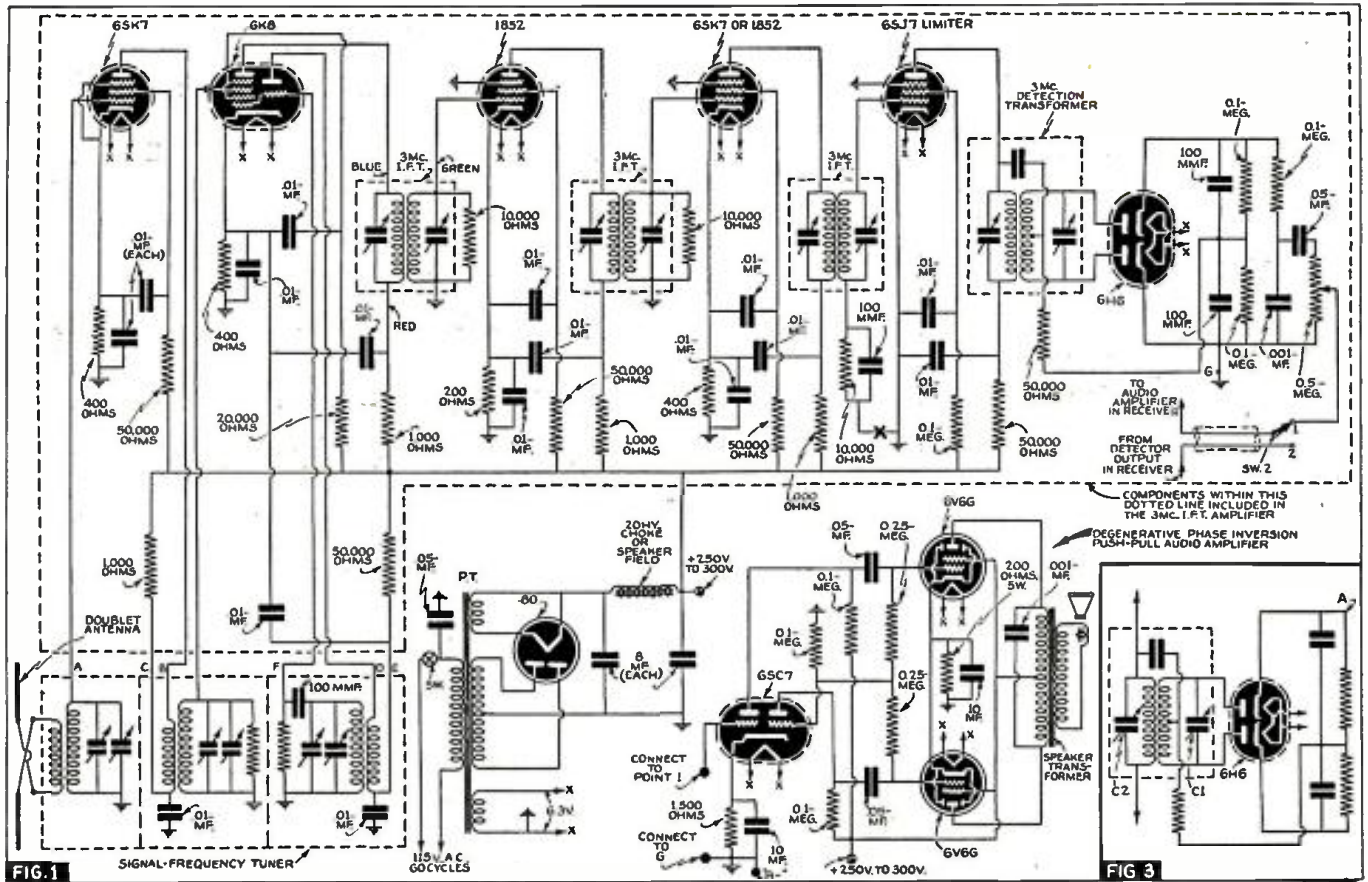

This representative circuit, of a model F.M. receiver, serves to illustrate the points on servicing these receivers discussed by Mr. Gaffney.

## F.M. SERVICING POINTERS

Many of the most recent articles concerning Frequency Modulation receivers have been devoted to analysis of the principles of operation. The following article, however, deals with the more specific problems, important to Servicemen, for obtaining maximum performance from currently-available F.M. sets.

F. J. GAFFNEY

**T**O begin with, despite the bugaboos which surround any new type of apparatus from the Serviceman's standpoint, there are many points of similarity between a Frequency Modulation receiver and an ordinary high-frequency Amplitude Modulation receiver.

The superheterodyne circuit, with or without a stage of preselection, is universally used and many of the testing procedures used on A.M. receivers can be transferred directly to F.M. receivers. The usual faults, for instance, such as open or shorted condensers, or open resistors, are equally as likely to occur with one type of receiver as with the other; and the usual methods such as those employing channel testers, etc., for ferreting out and correcting these troubles are employed.

### RECEIVER DIFFERENCES

There are however several points of difference in the 2 receivers. The most important of which are the wide-band I.F. amplifier employed and the entirely different method of detection used. As regards the I.F. system, a reasonably-wide-band system must be employed and this must be obtained without sacrifice of gain, since the noise-reducing ability of the receiver is de-

termined primarily by the degree to which the limiter tube is saturated, and this of course depends upon the I.F. voltage fed to the control-grid of this tube. The I.F. systems used for frequency modulation usually consist of 2 stages, exclusive of the limiter, and the gain from converter grid to limiter grid is of the order of 10,000 times. The high gain required in the I.F. system increases, of course, the possibility of instability unless all leads are kept at minimum length and components properly located on the chassis. The Serviceman is not primarily interested in design, but the above information is none the less valuable since in the replacement of any components in the I.F. system it must be borne in mind.

### TYPICAL F.M. SET

The diagram of a typical frequency modulation adapter is shown in Fig. 1. This unit is designed to work into the audio-frequency system of an existing amplitude modulation receiver or into any high-fidelity audio system such as the one shown. As far as the circuit diagram is concerned it is typical of many frequency modulation receivers.

It will be noted in the I.F. amplifier of this unit that all of the bypassing of screen-grids and decoupling plate resistors

is done to the cathode of the tubes, rather than to ground. This has been found to materially increase the stability of the unit, and is a suggestion, which may be of value to the Serviceman who may be confronted with instability problems.

The layout of the receiver, whose wiring diagram is shown in Fig. 1, is clearly shown

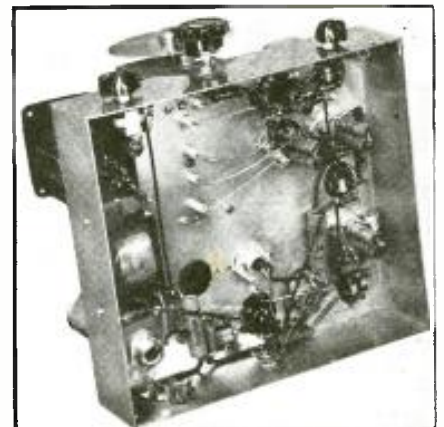

Underside of a representative F.M. receiver.



in the photograph (Fig. 2). Note that the screen-grid and decoupling bypass condensers are mounted vertically thus serving as a shield between the plate and control-grid circuits.

While the amplifier should be reasonably wide in its acceptance band, the problem of selectivity is by no means absent. It has been found that the I.F. system may be down 10 times 100 kc. away from the center frequency without any noticeable difference in audio quality resulting. The alignment of the I.F. system is perhaps best accomplished by means of a frequency wobbler. Unfortunately however, a unit is not believed to be available which has sufficient swing about a center frequency of 2 to 5 mc. (the customary F.M. I.F. band).

A method which will give entirely satisfactory results is that of aligning the I.F. system for maximum gain at the center frequency and then checking the response at 100 kc. either side of center, noting the symmetry of the system. For all I.F. and R.F. alignment a meter placed in the grid-return of the limiter load resistance (point "X" in the diagram) is by far the most useful indicator. A 0 to 5 ma. meter can conveniently be used for this purpose. Up to about 4 or 5 ma., the limiter current is nearly directly proportional to the I.F. voltage developed in the limiter grid.

The other point of similarity between amplitude and frequency modulation receivers is in the detection system. The most commonly used type of detector is shown in Fig. 3. The alignment of this detector must be done with great care since it is the most important factor in the receiver's ability to give noise-free reception.

The detector system is aligned in the following manner: A vacuum-tube voltmeter or a d'Arsonval type meter having a resistance of 10,000 ohms/volt and a 0-50 or 0-100 volt scale should be connected between point A and ground. A signal of the intermediate frequency is then fed to the control-grid of the converter tube and its amplitude then adjusted until a current of about 5 ma. is indicated in the limiter grid current meter. Condenser C1 is then adjusted until the voltmeter gives zero reading. A bakelite alignment tool without any metal tip should be used for this adjustment. The body-capacity effects to the rotor of C1 are very noticeable and it will be found extremely difficult to adjust this condenser with any other type of alignment tool. Having adjusted C1 to obtain zero reading of the voltmeter, the frequency of the signal fed to the mixer grid is made 50 kc. higher than the I.F. and the reading of the voltmeter noted. It may be necessary to reverse the connections to the voltmeter if the wrong polarity of voltage is obtained, unless a center-scale meter is being used. The frequency is then made 50 kc. lower than the I.F. and the voltage, which will now be in the opposite direction, is again noted.

The voltages obtained for 50 kc. above and below the center frequency should be equal. If they are not equal the condenser C2 is varied slightly and the process repeated until equal voltages are obtained. It is then necessary to reset condenser C1 to give zero voltage at the correct I.F. It will be found that the setting of C2 can be varied over a rather large range without materially affecting the setting of C1. The latter condenser, however, must be accurately set.

**TUNING INDICATOR**

There are 2 places in the receiver where a tuning indicator such as a 6U5 cathode-ray indicator may be employed. One is across the limiter grid resistor and the other is across the discriminator network

**OHMITE Ohm's Law Calculator**

**Solves any Ohm's Law problem with one setting of the slide**

There's nothing else like it! It's the handiest Ohm's Law Calculator ever made—specially designed for you by Ohmite Engineers. Gives the answer to any Ohm's Law problem with one setting of the slide. Simple, easy, complete. Requires no slide rule knowledge. All values are direct reading. Covers the range of cur-

rents, resistances, wattage and voltage commonly used in radio and commercial work. Also has convenient Stock Unit Selector—a setting of the slide tell the stock number of the resistor or rheostat you may need. Size 4 1/8" x 9". Available to you for only 10c to cover handling cost. At your Jobber, or send 10c in coin now.

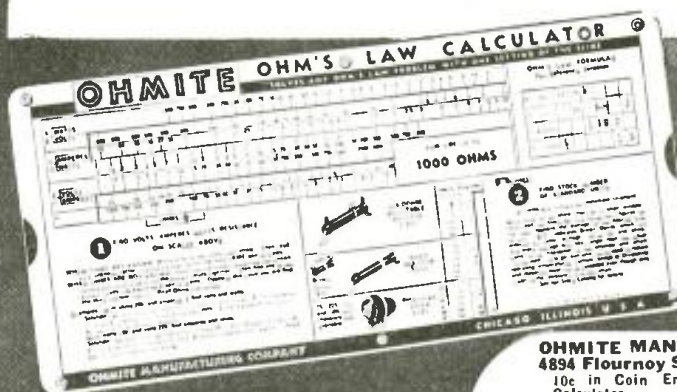

It's NEW

It's Complete

**OHMITE MANUFACTURING CO.**  
4894 Flounroy St., Chicago, Illinois  
10c in Coin Enclosed Send Ohm's Law Calculator.

Name \_\_\_\_\_  
Address \_\_\_\_\_  
City \_\_\_\_\_ State \_\_\_\_\_

Radio Craft—Jan

Be Right with OHMITE  
RESISTORS • RESISTORS • TAP SWITCHES

from point A to ground. Both positions have disadvantages. If the "eye" tube is placed across the limiter grid resistor, maximum closing of the eye may not be exactly the correct tuning point unless the receiver is perfectly aligned. The correct tuning point is for minimum noise rather than for maximum signal. Minimum noise is indicated by discriminator balance, that is, when the voltage from point A to ground is zero. A tuning eye does not lend itself to measuring this voltage very well, however, since the voltage goes positive and then negative when the receiver is tuned through the desired station. Nor does an eye in this position indicate the signal strength.

The gain of the receiver is adjusted until a current of about 3 ma. flows in the limiter grid resistor. This can best be accomplished by means of an I.F. gain control. The desired signal in the limiter control-grid can be indicated by a tuning eye arranged so as to just close when 3 volts negative appears across the limiter grid resistor. A.V.C. should not be used unless it is of the delayed type, such that about 30 V. at the intermediate frequency is developed at the control-grid of the limiter before the A.V.C. system begins to act. An A.V.C. system which is not delayed can seriously hamper the noise-reducing capabilities of the receiver. If a delayed A.V.C. system is used it may be checked by means of a vacuum-tube voltmeter across the A.V.C. network. This meter should give no indication until about 3 ma. flow in the limiter grid-return, as indicated by a current meter placed at this point in the circuit.

*This article has been prepared from data supplied by courtesy of Browning Laboratories, Inc.*

**POPULAR PRICE WITH REAL MUSICAL QUALITY!**



It has everything you need to bring customers into your store for records and keep them coming back for more. Quality crystal pickup, self-starting silent ring drive motor (also in 25, 50 cycle and AC-DC) built in high fidelity amplifier and speaker. Even thought model illustrated retails at \$14.95 the excellence of tone is so good that dealers use it as counter or booth record demonstrator. SEE and HEAR the MUSIC MASTER. Dealers write for proposition. **MUSIC MASTER MANUFACTURING CO.** 508 South Dearborn St. Chicago, Illinois

**DUMONT**

Precision Built Condensers

at your nearest jobber or write to

**DUMONT ELECTRIC CO., INC.**  
314-316 BROADWAY NEW YORK, N. Y.  
PAPER — MICA — ELECTROLYTIC

**CANADIAN SERVICEMEN**

can now purchase SUPERIOR Test Equipment direct from Radio Parts Supply Co., 962 Bleury St., Montreal Canada. They stock our complete line. See pages 419, 421, 423 in this issue. **SUPERIOR INSTRUMENTS CO.**

# A New A.F.-Drift Correcting, Signal-Balancing, Direct-Coupled F.M. 24-WATT AUDIO AMPLIFIER



This wide-range amplifier, which was partially described in a preceding issue, incorporates a new A.C.-D.C. balancing circuit. It is the perfect auxiliary for use with Frequency Modulation tuners, as it passes 13 to 30,000 ( $\pm 1$  db.) cycles, and has a noise level of 75 db. below rated output. Distortion is only 1% total harmonics at average working level! Push-pull balanced negative-feedback is incorporated.

A. C. SHANEY

PART II

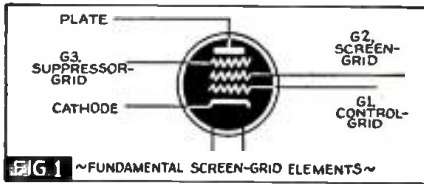

FIG. 1 ~ FUNDAMENTAL SCREEN-GRID ELEMENTS ~

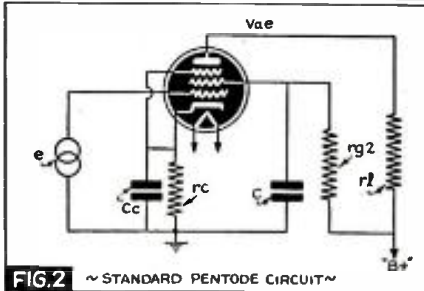

FIG. 2 ~ STANDARD PENTODE CIRCUIT ~

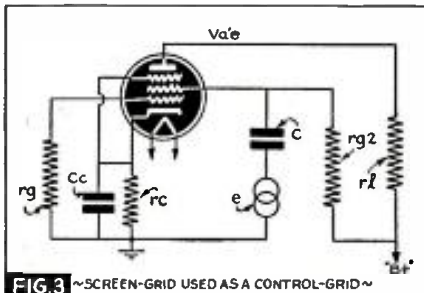

FIG. 3 ~ SCREEN-GRID USED AS A CONTROL-GRID ~

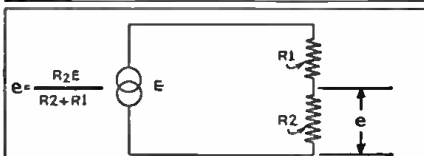

FIG. 4 ~ BASIC DIVIDER NETWORK ~

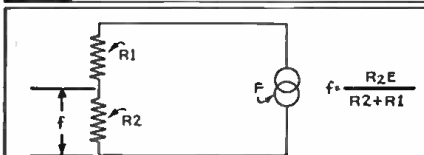

FIG. 5 DIVIDER NETWORK OPPOSITELY PHASED TO FIG. 4 CIRCUIT

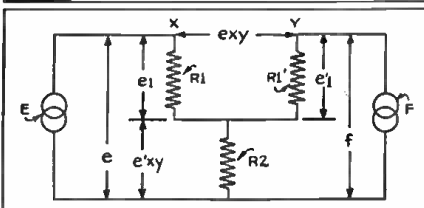

FIG. 6 ~ BASIC DYNAMIC BALANCER CIRCUIT ~

IN an effort to surpass the stability of conventional transformer- and resistance-coupled amplifiers, a combined D.C.-A.C. balancing circuit was developed. The D.C. balancer provides for automatic audio-drift correction under static conditions. The A.C. balancer provides for automatic signal balancing under dynamic conditions.

Stated in other words, the static balancer (D.C. corrector) automatically compensates for a very wide variation in plate resistance characteristics of input tubes. It prevents unbalance in the output stage with change of emission characteristics within the input stage. The dynamic balancer (A.C. corrector) automatically compensates for a very wide variation in voltage amplification of input tubes. It prevents the application of unbalanced signals to the control-grids of the output stage.

### THE DYNAMIC BALANCER (A.C. CORRECTOR)

The easiest way to understand the operating principles of this unusually effective circuit is to analyze the basic operating principles of the screen-grid tube. This tube is normally used in a conventional manner, i.e., by applying a control voltage to the control-grid; a "B+" voltage, adequately bypassed to the screen-grid; a "B+" voltage, through the load resistor to the plate; and, its suppressor-grid connected to cathode.

If these elements are viewed fundamentally as diagrammed in Fig. 1, it will be noted that all of the grids are in the electron stream. This means that any one of them can be used as a control-grid. Naturally, the further away the grid is from the emitter (cathode), the less control it has upon the electron stream. If the grids are labelled G1, G2, and G3, in order of their distance from the cathode, these notations will correspond to control-grid, screen-grid, and suppressor-grid, respectively.

Figure 2 shows a standard circuit, wherein the input signal (e) is applied to the control-grid, a signal  $V_{ae}$  will appear at the plate. This voltage will be out-of-phase with the input signal. If the screen-grid bypass condenser, C, is disconnected, and the voltage e is applied in series with the condenser, as illustrated in Fig. 3, a voltage  $V_{a'e}$  will appear on the plate.  $V_a$  may be defined as the control-grid to plate voltage amplification.  $V_{a'}$  may also be defined as the screen-grid to plate voltage amplification. It is therefore obvious that the screen-grid can be used as a control-grid. This particular application is important as it plays a prime role in our dynamic balancer.

The suppressor-grid may likewise be used as the control-grid in which case, the

I think the dynamic and static balancing circuit described in this article is one of the most interesting circuits I've ever developed. It shows what unconventional things can be done with conventional tubes. This circuit should find wide application in all standard all-push-pull resistance-coupled circuits as well as direct-coupled jobs. What it does for hum reduction and extension of the audio range is almost unbelievable.

A. C. SHANEY.

voltage which appears at the plate would be equal to  $V_{a'e}$  (wherein  $V_a$  may be looked upon as the suppressor-grid to plate voltage amplification).

### PRINCIPLES OF DYNAMIC BALANCING

With the above phenomenon kept in mind, a review of fundamental balancing circuits will further simplify the operating principles of the dynamic balancer. If an A.C. generator E is applied to a series resistive network R1, R2, as illustrated in Fig. 4, the voltage (E) appearing across R2 is equal to

$$E \cdot \frac{R_2}{R_1 + R_2}$$

Expressed mathematically, it becomes  $e = \frac{R_2 E}{R_1 + R_2}$ .

If another identical generator F is connected to a similar resistance network R1, R2, the voltage (f) which appears across R2 is likewise equal to  $f = \frac{R_2 F}{R_1 + R_2}$ . If both

- circuits of Figs. 4 and 5 are connected together, so that R2 becomes a common return, Fig. 6 results. If the generators E and F are so adjusted as to be equal in potential but opposite in phase, and  $R_1 = R_1'$ , the following voltage conditions are present:
- (1) The voltage across E (e) is obviously equal to the voltage across F (f).
  - (2) The voltage across  $R_1$  (e) is equal to the voltage across  $R_1'$  ( $e'$ ).
  - (3) As the voltages are out-of-phase, it is also obvious that the voltages across R2 will cancel, and equal 0.
  - (4) The voltages across X and Y ( $e \cdot xy$ ) will also cancel and be equal to 0.

The above conditions are prevalent only when the generators are opposite in phase and of equal potential. If we assume, however, that one of these generators drops in voltage, let us say to 50%, of its original value, it is apparent that the total difference will be equal to  $e - f$  or  $e \cdot xy$ . With an un-



balance in the generators it is further apparent that complete cancellation will not occur across R2. In fact, some of the larger voltage will appear at this point. This voltage ( $e'_{xy}$ ) is equal to

$$E \frac{R2}{R2 + R1} - F \frac{R2}{R2 + R1} = e'_{xy}$$

An examination of this formula shows that as R2 is increased, more of the unbalanced voltage appears across it. If this voltage unbalance ( $e'_{xy}$ ) is applied back to F, so as to increase its voltage output, it is obvious that some balance will automatically be obtained.

### THE DYNAMIC PLATE BALANCER

How this is actually done in the amplifier can best be indicated by redrawing Fig. 6 and replacing E and F by their respective tube circuits, as indicated in Fig. 7. In this circuit, the push-pull generator EF, takes the place of the original generators E and F. R1 becomes the independent plate loads of both tubes, while R2 becomes the common degenerative resistor. If both tubes A and B have identical voltage amplification characteristics, the voltage which appears across R2 will be 0. On the other hand, if A has twice the voltage amplification of B, then a portion of this difference will appear across R2.

A typical example is given in Fig. 8, wherein the plate load resistors R1 equal 100,000 ohms each, the common degenerative resistor R2 is equal to 400,000 ohms. If we assume that the voltage amplification of one tube (A) is 20, and the other tube (B) is 10, and if a balanced push-pull signal (grid-to-grid of 2 volts) is applied to the input of the circuit, the voltage which appears at the plate of A is equal to say, +20 volts (the voltages indicated are instantaneous A.C. voltages). The voltage which appears at the plate of B is equal to -10 volts. If these signals are out-of-phase, there will be a total voltage difference between both plates of 30 volts (for ideal conditions, there should be a total voltage difference of either 20 volts [if both plates have 10 volts each] or 40 volts [if both plates have 20 volts each]).

The portion of the voltage developed by plate A which appears across the 400,000-ohm resistor, is equal to

$$+20 \times \frac{400,000}{400,000 + 100,000} = 20 \times \frac{4}{5} = +16 \text{ volts}$$

The portion of the voltage developed by plate B which appears across the 400,000-ohm resistor is equal to

$$-10 \times \frac{400,000}{400,000 + 100,000} = -10 \times \frac{4}{5} = -8 \text{ volts}$$

The cancellation which occurs across the 400,000-ohm resistor is equal to 16 - 8 or + 8 volts. This instantaneous value of + 8 volts is fed back to the screen-grids of both tubes to affect further automatic connection. Before considering the balancing action of this voltage, let us briefly look into the screen-grid circuit.

### THE DYNAMIC SCREEN-GRID BALANCER

The fundamental principles involved in the dynamic screen-grid circuit are virtually identical with those for the plate dynamic balancer. There are, however, 2 important exceptions.

In our conventional circuit of Fig. 2, it will be noted that the screen-grid was bypassed to ground through C. If this condenser is entirely removed, a voltage will appear at the screen-grid, which is equal to  $V_{a''e}$  ( $V_{a''}$  being the control-grid to screen-grid voltage amplification). If the rest of the circuit of Fig. 2 remains un-

changed, it will be found that the voltages  $V_{ae}$  and  $V_{a''e}$  will be in-phase. The voltage  $V_{ae}$  however will be decreased. This is caused by the degenerative action of the voltage which appears at the screen-grid. Its degenerative action can best be analyzed by referring again to Fig. 1. If a positive instantaneous voltage is applied to G1, the electron stream is increased. The increased current through G2, produces a drop across its supply resistor. This, in turn, decreases the applied potential of C2 to retard the flow of electron streams to the plate. As the control-grid to screen-grid voltage amplification increases, the control-grid to plate voltage amplification decreases. Very large signals can easily be handled by the screen-grid under this condition.

Figure 9 shows the elements of the dynamic screen-grid balancer circuit, arranged to simulate the plate dynamic balancer of Fig. 8. It will be noted, however, that an essential difference is the inclusion of the condenser Cg2. If the control-grid to screen-grid characteristics are identical in both tubes, complete cancellation of the voltages which appear at both screen-grids will take place, as discussed for the conditions illustrated in Fig. 6. Let us assume for a moment however, that the control-grid to screen-grid characteristics of tube B, are lower than that of A. This naturally means that complete cancellation will not take place across both screen-grids and a residual potential will appear at the screen-grid of tube A. This voltage will then drive the screen-grid of B in a very conventional resistance-coupled circuit, which can easily be perceived by redrawing Fig. 9, as indicated in Fig. 10.

Here it will be noted that the screen resistor R3 of tube A acts as an equivalent "plate load". Condenser Cg2 assumes the role of the common coupling condenser. The screen-grid of B acts as the control-grid. The voltage which appears at the plate of B will be out-of-phase with that which appears at the plate of A because of the following reasons: when the control-grid of tube A is being used as a driver, and it becomes instantaneously positive, both the plate and its screen-grid become instantaneously negative. The negative screen-grid of tube A is coupled to drive the screen-grid of tube B negatively. This in turn produces an instantaneous positive potential at the plate B.

With correct selection of values, this circuit may be made to operate as a perfect inverter, and shows how complete balancing may be attained even though the control-grid of tube B is entirely inoperative. In actual practice, however, such a condition is rarely encountered. What usually happens is the control-grid to screen-grid voltage amplification of both input tubes are not always equal. This coupling circuit equalizes the difference within the first stage so that practically equal but oppositely-phased voltages appear at the push-pull output plates of A and B.

In addition to the dynamic screen-grid balancer and the dynamic plate balancer, there is an auxiliary regenerative balancer which comes into play when the common coupling resistor of the plate supply, R2 is coupled to the common coupling resistor of the screen supply, R4, through condenser Cg3, as indicated in Fig. 11. If we redraw this schematic again so as to take the form of a more familiar coupling circuit, we have Fig. 12. Here, it will be noted, the full potential difference which appears across R2 (400,000-ohm resistor of Fig. 8) is applied through Cg3 and through both R3 resistors directly to the screen-grids of both tubes. If we assume that the control-

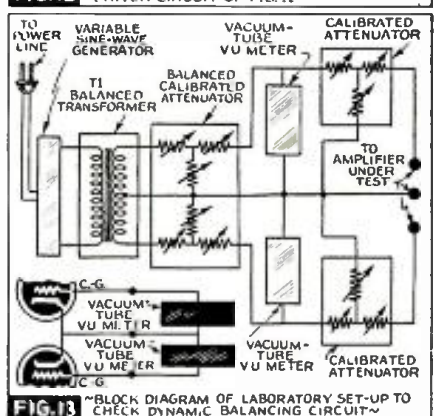
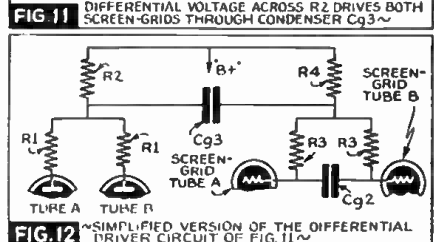
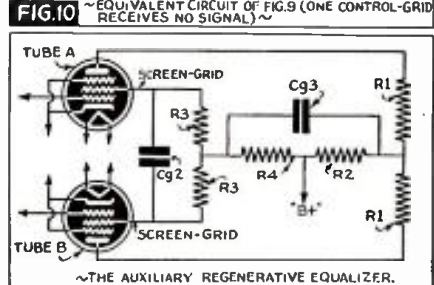
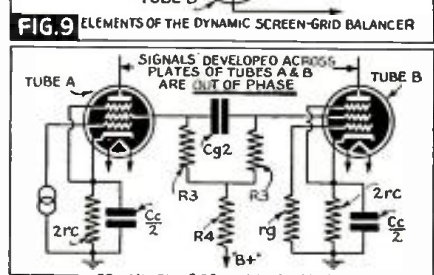
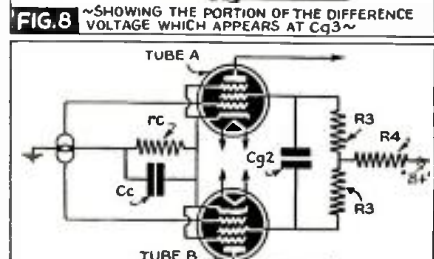
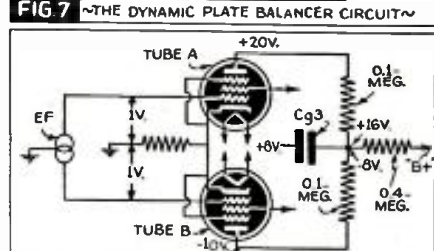
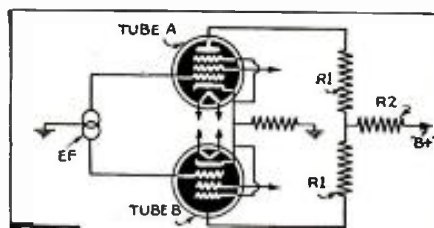

## STEP UP YOUR SHOP PROFITS with Atlas EQUIPMENT



### EASY TO OPERATE

It's easy to turn out your own machine work on an Atlas Lathe—and make for yourself the profits you now have to pay others.

Radio Servicemen in all sections find that the Atlas Lathe makes quick work of dial shafts and drums, knobs, special screws and studs; service tools, microphones, special dies and molds. Operating instructions show correct gear set-ups for winding R.F., choke, and short wave coils, transformers.

### Send Coupon for FREE 1941 Catalog

See the many operations you can do in your own shop with Atlas Equipment. Send the coupon below today for full details.

# Atlas

LATHES • DRILL PRESSES • ARBOR PRESSES  
METAL SHAPERS • VISES • CIRCULAR SAWS

**ATLAS PRESS CO.**  
145 N. Pitcher St., Kalamazoo, Mich.

Please send me your 1941 Catalog on  6" Metal Lathes  10" Metal Lathes  New Milling Machine  7" Metal Shaper  Drill Presses  Arbor Presses.

Name .....

Address .....

City and State .....

Turn to Page 390  
for the Best Book on Sound!

## WORLD'S GREATEST all around ELECTRIC TOOL

**DRILLS—GRINDS—SANDS—SAWS  
POLISHES—SHARPENS—CARVES**

The new WHIZ ELECTRIC TOOL is the handiest power tool ever made. A rugged tool for power and precision work. Drills through 1/2 inch iron plate in 42 seconds or engraves intricate designs. Handles any material: Metals—Woods—Alloys—Plastics—Glass—Steel—etc. Saves time. Eliminates labor. Plug into any socket AC or DC. 110 volts. Chuck 3/4 inch capacity. Ball bearing thrust. Powerful, triple-gear motor. STANDARD MODEL with Normal Speed (uses 200 different accessories, instantly interchangeable). Price only \$7.95. The only DRILL-TOOL with a full year's guarantee.

**FREE** Accessory outfit (Value \$2) includes set of drills, mounted 1 1/2 inch grinder, sanding discs, cutting wheels, mounted brush, polishing wheel, carving bur, etc. **FREE** with each tool ordered **NOW**. We pay postage.

**10-DAY TRIAL—MONEY BACK GUARANTEE.**  
PARAMOUNT PRODUCTS CO.  
Dept. 1RC, 545 Fifth Ave., New York

grid to screen-grid voltage amplification of both tubes is equivalent (for simplicity of explanation), then the residual instantaneous +8 volts of Fig. 8 is applied directly to both screen-grids without any additional cancellation. This instantaneous positive voltage also acts as a driving voltage to the screen-grid of tube B to further increase the negative swing of its plate. In actual practice, circuit values can be adjusted to automatically correct for any desired range of variation between tubes. Laboratory tests, however, simplify the determination of optimum values for maximum D.C. static correction, maximum A.C. dynamic correction and minimum loss of overall gain.

### LABORATORY TEST SET-UP

For checking the degree of balance obtainable, the laboratory equipment indicated in Fig. 13 was used. The coupling transformer T1 was used to obtain a push-pull signal. Two vacuum-tube VU meters were used across each half of the push-pull input signal to enable exact adjustments of input voltages. Individual calibrated attenuators were used to vary the amount of input signal fed into each half of the push-pull stage.

It was found that when full signal was fed into one grid and no signal into the other, a 50% balance occurred. In other words, one output grid developed a voltage 50% of the other and exactly 180° out-of-phase. With a 50% variation in input signal, 80% balancing occurred. In other words, when half as much signal was fed into one input grid, as compared to the other, its associated output grid had 4/5 of the voltage which appeared on the opposite push-pull output grid. This signal was also exactly 180° out-of-phase. Both of these conditions represent extreme abnormalities. Over 100 combinations of input tubes were checked for variations in voltage amplification. It was found that the greatest variation of tubes produced a difference of less than 5% between both output grids.

How this output grid voltage is further balanced by the action of the feedback circuit will be explained in the next issue of *Radio-Craft*. In the meantime the author will be pleased to answer any questions relative to this new static and dynamic balancing circuit. Address all inquiries care of *Radio-Craft* (and please include a self-addressed and stamped envelope).

### NEWS SHORTS

"The War Department appreciates the great power of radio in reaching, effectively, the great mass of the people of the country with any message or program in a minimum of time," said Major-General E. S. Adams, Adjutant General of the U.S. Army, in a letter to the N.A.B. The reference was in connection with the use of radio by the Army at the recent maneuvers in northern New York, and the 69 action broadcasts which were made.

Stewart-Warner's radio-division manager accomplished the seemingly impossible feat of addressing 78 distributor-dealer meetings held in as many cities throughout the U.S., by sending to each group a sound-recording of his talk on the new models.

Quite appropriately, Fischer Musical Instrument Co., Inc., now handling the home-recording device called the "Recordio," took over sponsorship of WMCA's "Radio News Reel" featuring a resumé, on phono records (transcriptions), of sound-recorded news of the week.

## OPPORTUNITY AD-LETS

Advertisements in this section cost 15 cents a word for each insertion. Name, address and initials must be included at the above rate. Cash should accompany all classified advertisements unless placed by an accredited advertising agency. No advertisement for less than ten words accepted. Ten percent discount six issues, twenty percent for twelve issues. Objectionable or misleading advertisements not accepted. Advertisements for February, 1941, issue must reach us not later than December 7th.

Radio-Craft • 20 Vesey St. • New York, N. Y.

### BOOKS AND MAGAZINES

**ASSURE YOURSELF OF GREATER PROFITS BY** doing radio service jobs more quickly. Authentic service guides show you the way to locate and correct troubles in any radio receiver. *Gernsback Official Radio Service Manuals* show you how to complete more repair jobs in less time—how to earn more money by faster servicing. *Radcrafter Publications*, 20 Vesey St., New York City.

**WE HAVE A FEW HUNDRED RADID ENCYCLOPEDIAS**, by S. Gernsback, second edition, originally sold at \$2.98. Book has 352 pages, weight 13 lbs., size 9 x 12 inches. Red morocco—keratin flexible binding. Send \$2.49 in stamps, cash or money order and book will be forwarded express collect. *Technifax*, 1915 So. State Street, Chicago, Illinois.

**WHAT DO YOU KNOW ABOUT AMPLIFIERS AND SOUND SYSTEMS?** The *Amplifier Handbook and Public Address Guide* covers P.A. from A to Z. Most complete and authentic book published on the subject. Contains 80 pages of vital information on Amplifiers, P.A. Systems, Speakers, Accessories, Pickups, Microphones, etc. Printed on fine coated stock, with numerous photographic illustrations and explanatory diagrams, and only 25c. See page 320.

### DIATHERMY MACHINES

**FOR SALE—DIATHERMY MACHINE, CUSTOM-BUILT** by radio engineer. Machine substantially built with high patient safety factor. 250-300 watts output. Neat professional appearance. Automatic safety time switches. All necessary pads and electrodes. 16 meters. Cost \$350.00. Will sacrifice for \$150.00. Less than 1 year old. Will demonstrate. Write for appointment. *L. FELDMAN*, 566 W. 191st Street, Apt. 15, New York City.

### EDUCATIONAL COURSES

**USED CORRESPONDENCE COURSES AND EDUCATIONAL BOOKS** bought, sold or Rented. Catalog Free. *Vernon Exchange*, Hensgar, Ala.

**CORRESPONDENCE COURSES AND EDUCATIONAL BOOKS**, slightly used. Sold, Rented, Exchanged. All subjects. Satisfaction guaranteed. Cash paid for used courses. Complete details and bargain catalog FREE. Write *Nelson Company*, 500 Sherman, Dept. A-242, Chicago.

### MANUSCRIPTS WANTED

**WANTED—MANUSCRIPTS, POEMS, SONGS** FOR publication. *Fortuny's*, 87 Fifth Ave., New York.

### PATENT ATTORNEYS

**INVENTORS—PATENT YOUR INVENTION—SEND** now for our new FREE copyrighted booklet, "How to Protect Your Invention," and "Invention Record" form. This booklet guides the inventor from the first step toward patent protection to final profit-making from his invention. Reasonable fees, conscientious counsel. *McMorrow and Berman*, Registered Patent Attorneys, 178-A Barrister Building, Washington, D. C.

### PHOTOGRAPHY

**1/100,000 OF A SECOND SPEED FLASH UNIT** for Stroboscopic Photography. \$200.00. Apt. 63, 782 West End Ave., New York City.

### RADIO

**WE BUY AND SELL USED RADIO TESTING EQUIPMENT.** Time Payments if desired. *Harold Davis, Inc.*, Jackson, Miss.

**DO YOU HAVE ANY OF THESE RADIO ITEMS? WILL** swap car-radio set, photographic equipment (or what do you want?), etc. for the following: electrolytic detector, slide-plate variable condenser (preferably United), Magnatone model TRF-5 set, early studio-type carbon microphone in metal case, spark gap and "Thoradron" "Flexible" transformer, Tuska "Superdye" diamond-Morlan wooden case brass-plate condenser, "Grant" loudspeaker. *H. Bernard*, 40 Manning Ave., No. Plainfield, N. J.

### RADIO KITS

**RADIO KITS—\$3.95 UP. SINGLE BAND; ALL WAVE.** 5-10 tubes. Fluorescent lighting. Save 50%. *McGee Radio*, P-2055, K.C., Mo.

### STAMPS

**WANTED 10,000,000 USED U.S.A. STAMPS.** SEND for Appraisal. Stamps Sold on Credit. Collections or Singles. *Brooks*, 22 Glen Rock Ave., Malden, Mass.

### TECHNICAL ART SERVICE

**DRAFTING AND ART SERVICE—A COMPLETE** Service for the Industrial and Commercial Markets. If your business or plant can't afford a designing or drafting staff, don't let this stop you from going ahead with that new product you intend marketing, or that catalog of mechanical or electrical items which needs fine detailed drawings and highly retouched photographs. Any mechanical, electrical or radio problem can be solved for you by our associated staff of designers, draftsmen and artists, and technical copywriters. Write for any additional information as to methods and price for this service. *Tex-Art Drafting Service*, 228 Charlotte Terrace, Roselle Park, N. J.

**DRAFTING SCHEMATIC DIAGRAMS SEND US** a rough sketch of your circuit. Estimates by return mail. Our prices are moderate; our work guaranteed. No jobs too big or small. *Wm. Kadlecck, Jr.*, 440 East 85th St., New York, N. Y.



# 4

# Star Performers!

## PROGRESSIVE SERIES PLAN

Howard's revolutionary direct factory conversion set-up enables you to own at all times the finest receiving equipment—without loss or unfavorable trade-in deals. It is the most flexible and all-in-your-favor purchase plan in existence. Inquire today!

# HOWARD

## COMMUNICATION RECEIVERS



### MODEL "435"

An outstanding performer on all bands. 6 tubes, electrical band spread, ceramic coil forms, BFO, AVC, built-in 6½ inch speaker and iron core IF's. Tunes 540 KC to 43 MC in four bands. The finest low priced receiver available. **\$29<sup>95</sup>**

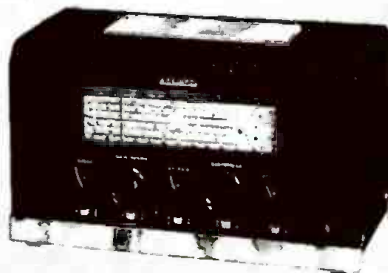

### MODEL "436"

7 tubes. Contains all features of Model 435 but adds noise limiter, flywheel inertia tuning controls and micrometer band spread dial. **\$39<sup>95</sup>**



### MODEL "437"

9 tubes. Provides RF preselection, 2 IF stages, crystal filter, noise limiter, electrical band spread, built-in speaker and other important features. A top performer. **\$54<sup>50</sup>**

(With Crystal \$62.00)

See these HOWARD Receivers at Your Dealer Today!

*—Acclaimed By Short Wave Listeners and Amateur Operators Alike!*

Quality at a price that isn't "loaded" will always command a buyer's attention. That's why HOWARD Communication Receivers sell in steadily growing volume. Every HOWARD Receiver is truly a triumph of design, performance, beauty and engineering craftsmanship—each developed to meet the exacting demands of today and tomorrow.

Owners everywhere have been literally amazed by the abundance of exclusive features found in the 1941 HOWARD Communication Receivers. Dollar for dollar, the outstanding performance of these great receivers is unsurpassed—they represent America's finest values. Be sure to see the brilliant new HOWARD Models before you buy any receiver.

Export and Pacific Coast Prices Slightly Higher



### Model "490"

For those desiring a single unit receiver that establishes new standards of performance, the new 14 tube HOWARD 490 is outstanding in every respect. Has sensitivity that never knows crowding and selectivity that may be varied at will from the hairline sharp position required for CW to wide range for high fidelity reproduction. 2 RF stages, calibrated band spread, 9 position variable IF selectivity, air-tuned IF transformers, temperature compensated oscillator, automatic noise limiter, variable audio fidelity, 8 watt push-pull output. Comes complete with 14 tubes, crystal filter and 10 inch external dynamic speaker in matching cabinet. **\$149<sup>50</sup>**

# HOWARD RADIO COMPANY

1731-35 Belmont Ave., Chicago, Ill. Cable Address: HOWARDCO., U. S. A.

*America's Oldest Radio Manufacturer*

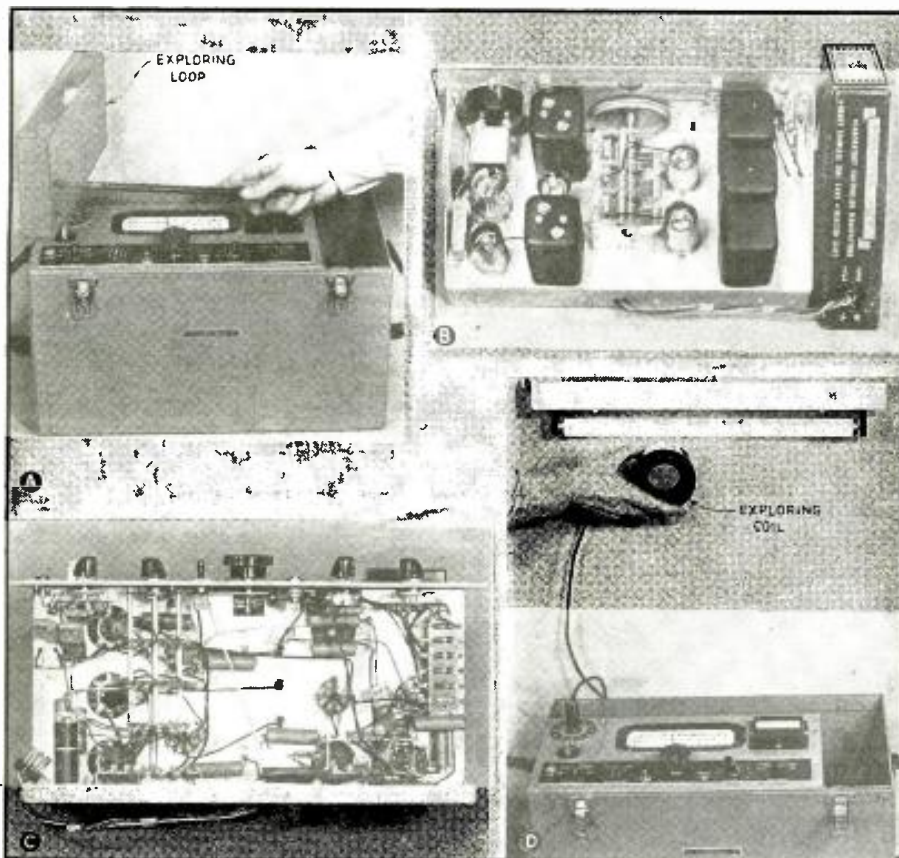

Here are the complete construction details of an Ultra-Modern Noise Locator as especially designed for Radio-Craft by a well-known engineer. Frequency coverage: 140-425 kc., 540-1,600 kc. and 2,500-7,000 kc. A built-in Wien Bridge permits oscillographic study of interference on A.C. lines (with the line frequency removed by the Bridge). This locator was designed to meet all possible needs of Servicemen who wish to specialize in commercial interference work.

A.—Operation of Interference Locator with the loop antenna. B.—Top-rear view of the chassis. C.—Underside of the chassis. D.—Exploring coil in use measuring the interference radiation intensity from a fluorescent lighting unit.

## How to Make a Modern INTERFERENCE LOCATOR

PAUL O'CONNOR

INCREASING numbers of radio men are finding a welcome increase in their income through the medium of the public demand for radio installations free from avoidable interference. All types of man-made radio interference may be classed as "avoidable" and, in most cases, the set owners or the operator of the device producing the interference are willing to pay the cost of installing suitable filters, provided that they are certain of getting something for their money.

### REQUIREMENTS

Radio interference filters are today available for almost every conceivable type of interference-producing device, but proper installation of the correct filter is necessary, if satisfactory results are to be obtained. A suitable portable radio receiver is a valuable service tool in locating the source of interference and in checking the effectiveness of the filter installation. While the ordinary portable battery-operated receiver, equipped with an output meter, is better than no receiver at all, it is not sufficiently versatile to be used as a really satisfactory interference locator.

The receiver, or Interference Locator, to be described in the following paragraphs has been used for the past few months for almost all types of radio interference work, ranging from household vacuum cleaners to large marine generators, and has been invaluable in making a rapid diagnosis of

each problem. It weighs about 21 lbs., complete.

The frequency range of this modern Interference Locator is as follows: Band No. 1 (L.W.), 140 to 425 kc.; Band No. 2 (B.C.), 540 to 1,600 kc.; and, Band No. 3 (S.W.), 2,500 to 7,000 kc. This range covers the standard broadcast band, the longwave aircraft radio range and weather report band, and the high-frequency airline communication band. The high-frequency band also covers most of the marine band—ship-to-ship, ship-to-Coast Guard and ship-to-shore radio telephone. The Locator will be found extremely useful when making radio installations in small boats where most of the electrical system is in open wiring.

### CIRCUIT FEATURES

The circuit of the Locator, except for the input and meter circuits, is a conventional battery superheterodyne, but does not use A.V.C., since the manual sensitivity control makes it more convenient to make comparative measurements of interference levels in different positions.

**Output Meter.**—The output meter is a 0-100 microampere meter and is used to measure battery voltages as well as audio-frequency and radio-frequency carrier levels. The meter switch connects the meter in the circuit selected. As a D.C. voltmeter "A" and "B" battery voltages are read with a sensitivity of 10,000 ohms/volt. The "A" battery range is 2 volts full-scale and the

"B" battery range is 100 volts full-scale. The readings of the A.F. and R.F. scales are arbitrary units and are merely used for reference. The "A.F. HIGH" range is about 5 times that of the "A.F. LOW" range. The diode plate of the 1D8GT tube is used as a rectifier for the audio and carrier voltages.

**Loop Antenna.**—The input circuits of the Locator provide for both radiation noise and conductive noise measurements, the latter being very effective in checking the "before-and-after" results of the installation of line filters and in checking the amount of interference present in different wiring circuits in a given location.

The loop antenna may be used for determining the best plane in which to locate a receiving antenna. It may also serve as an emergency direction finder, although it does not have sufficient accuracy to be used as a navigation instrument.

The loop antenna is provided with a bakelite rod so that adjustments of the loop may be made without having body capacity effects, since the loop is not provided with an electrostatic shield. Due to the comparatively small size of the loop, no electrostatic shield was used, thus maximum sensitivity is obtained from the loop. The compass rosette, mounted under the loop jack so that it is free to turn, can be used for taking rough direction bearings.

**Exploring Coil.**—The exploring coil may be used to follow the course of noisy elec-



# — BUY DIRECT FROM THE MANUFACTURER AND SAVE —

WE KNOW OUR PRICES ARE VERY LOW and expect a certain amount of skepticism from servicemen who have never purchased the SUPERIOR way, but five years of sticking to our way of doing business has convinced us and many thousands of servicemen who have purchased from us that it is a practical and mutually profitable way of doing business. We know that the average income of the Radio Serviceman prohibits his purchasing high-priced equipment, and yet the very nature of his work makes it necessary for him to use accurate, dependable and up-to-date equipment. We know we have solved the problem for him and our continually expanding business proves that servicemen recognize this claim to be true.

BESIDES THE THOUSANDS OF SERVICEMEN AND TECHNICIANS, THE FOLLOWING WELL-KNOWN NAMES ARE LISTED AMONG SUPERIOR INSTRUMENT PURCHASERS: Standard Oil Company of New Jersey; U. S. Dept. of Agriculture; U. S. Dept. of Commerce; U. S. War Department; C.C.C. Camps; National Youth Administration; Goodyear Tire and Rubber Co.; E. I. duPont de Nemours & Co.; University of Nebraska; Leland Stanford Junior University; Westminster College; Oberlin College; University of Michigan; Boston College; Pomona College; Board of Education, Remus, Michigan; Board of Education, City of New York; Board of Vocational Education, State of Illinois; City of Bartow, Florida; Florida State Dept. of Education; Educational Dept., Custer, North Dakota.



The New Model 1220  
**POCKET LABORATORY**  
★ WEIGHS ONLY 28 OUNCES!!  
★ USES A 2% ACCURATE 0-200 MICROAMMETER—ENABLING MEASUREMENTS AT 5000 OHMS PER VOLT

- SPECIFICATIONS**
- ★ 6 D.C. Voltage Ranges: 0-3-10-50-250-500-5,000 volts.
  - ★ 3 A.C. Voltage Ranges: 0-15-150-1500 volts.
  - ★ 4 Resistance Ranges: 0-3000 ohms, with 15 ohm center, direct reading to 0.2 ohm; foregoing base range multiplied by 10, by 100 and by 1,000, to read up to 3 Meg. with self-contained 3 V. flashlight battery.
  - ★ D.C. Current Ranges: 0-200 microamperes; 0-2-20-200 Milliamperes, using wire-wound shunts.
  - ★ 3 Output Meter Ranges: Same as A.C. Voltage Ranges.
  - ★ 3 Decibel Ranges: From -2 to +58 D.B., based on .006 watt in 500 ohms.

Model 1220 comes complete with cover, self-contained battery, test leads and instructions. ONLY **\$10<sup>45</sup>**

## THE NEW CHANNEL-ANALYZER

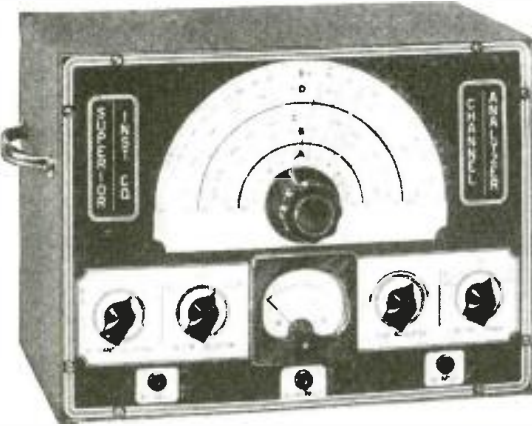

FOLLOWS THE SIGNAL FROM ANTENNA TO SPEAKER OF ANY SET

The well-established and authentic SIGNAL TRACING METHOD of locating the very circuit in which there is trouble, and the very component that causes the trouble, is now for the first time available at a price any radio serviceman can afford.

### THE CHANNEL-ANALYZER WILL

- ★ Follow the signal from antenna to speaker through all stages of any receiver ever made.
- ★ Instantly track down exact cause of Intermittent operation.
- ★ Measure both Automatic-Volume-Control and Automatic-Frequency-Control, voltages and circuits without appreciably loading the circuit, using built-in highly sensitive Vacuum-Tube Voltmeter.
- ★ Check exact gain of every individual stage in receiver.
- ★ Track down and locate cause of distortion in R.F., I.F., and A.F. amplifier.
- ★ Check exact operating voltage of each tube.
- ★ Locate leaky condensers and all high-resistance shorts, also show opens.
- ★ Measure exact frequencies, amount of drift and comparative output of oscillators in superhets.
- ★ Track down exact cause of noise.

The Superior Channel-Analyzer comes housed in shielded cabinet and features an attractive etched aluminum panel. Supplied complete with tubes, three specially engineered shielded input cables, each identified as to its purpose. Also full operating instructions. Size 13" x 10" x 6". Shipping weight 19 pounds. Only **\$19<sup>75</sup>**

## The New Model 1240 TUBE TESTER



Instantaneous snap switches reduce actual testing time to absolute minimum. Tests all tubes 1,4 to 117 volts. Sockets for all tubes — No adapters.

### SPECIFICATIONS:

- ★ Tests all tubes, 1,4 to 117 volts, including 4, 5, 6, 7, 2L, octals, octotals, Bentam, Jr., Peanut, single ended, floating filament, Mercury Vapor Rectifiers, the new S series, in fact every tube designed to date.
- ★ Spare socket included on front Panel for any future tubes.
- ★ Tests by the well-established emission method for tube quality, directly read on the GODD ? BAD scale of the meter.
- ★ Jewel protected neon.
- ★ Tests shorts and leakages up to 2 megohms in all tubes.
- ★ Tests leakages and shorts in all elements AGAINST all elements in all tubes.
- ★ Tests BDM plates in rectifiers.
- ★ Tests individual sections such as diodes, triodes, pentodes, etc., in multi-purpose tubes.
- ★ Latest type voltage regulator.
- ★ Features an attractive etched aluminum panel.
- ★ Works on 90 to 125 volts 60 cycles A.C.

Model 1240 comes complete with instructions and tabular data for every known type of receiving tube. Shipping weight 12 pounds. Size 6" x 7 1/2" x 10 1/2". Our Net Price **\$11<sup>85</sup>** Portable cover \$1.00 additional

## MODEL 1230 SIGNAL GENERATOR



WITH FIVE STEPS OF SINE-WAVE AUDIO

### SPECIFICATIONS:

1. Combination R.F. and A.F. Signal Generator, R.F.—100 K.C. to 90 Mcgacycles, A.F.—200 to 7500 cycles; Sine-Wave.—WITH OUTPUT OF OVER 1 VOLT. All direct reading, all by front panel switch manipulation.
  2. R.F. and A.F. output independently obtainable, alone or with A.F. (any frequency) modulating R.F.
  3. Latest design full-range attenuator used for controlling either the pure or modulated R.F.
  4. Accuracy is within 1% on i.f. and broadcast bands; 2% on higher frequencies.
  5. Giant dial etched directly on front panel, using a new mechanically perfected drive for perfect vernier control.
  6. Operates on 90 to 130 V. A.C. or D.C. (any frequency).
- The Model 1230 comes complete with tubes, shielded cables, molded carrying handle and instructions. Size 14" x 6" x 11". Shipping weight 15 pounds. Only **\$12<sup>85</sup>**

# SUPERIOR INSTRUMENTS CO. 136 Liberty St., Dept RC-1 New York, N.Y.

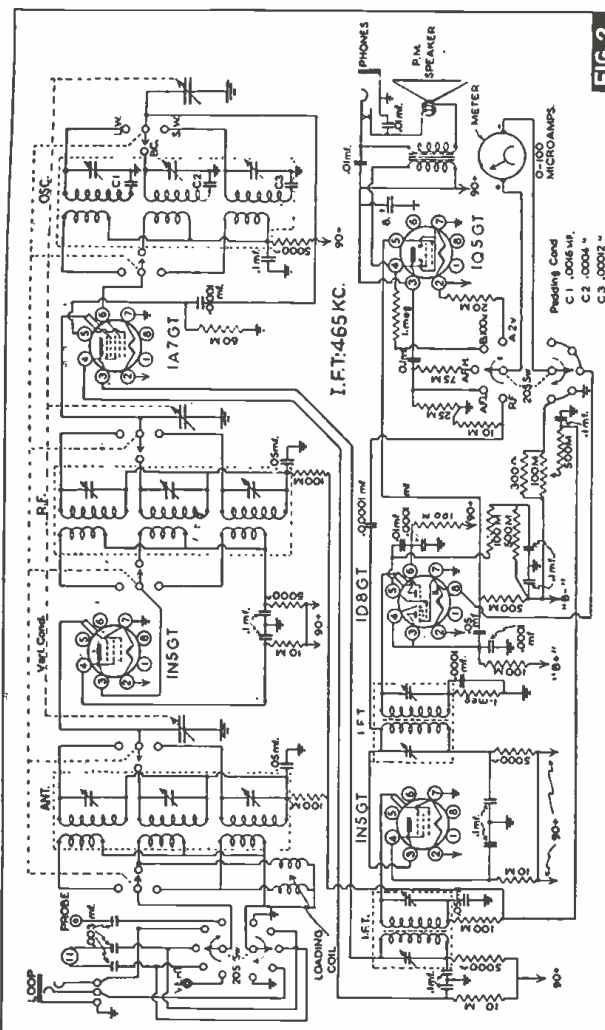

FIG. 2

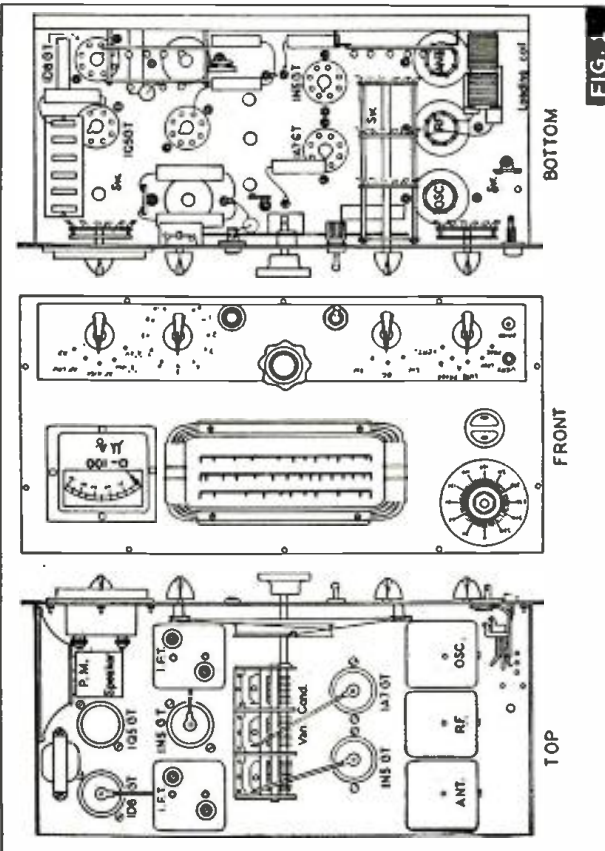

FIG. 1

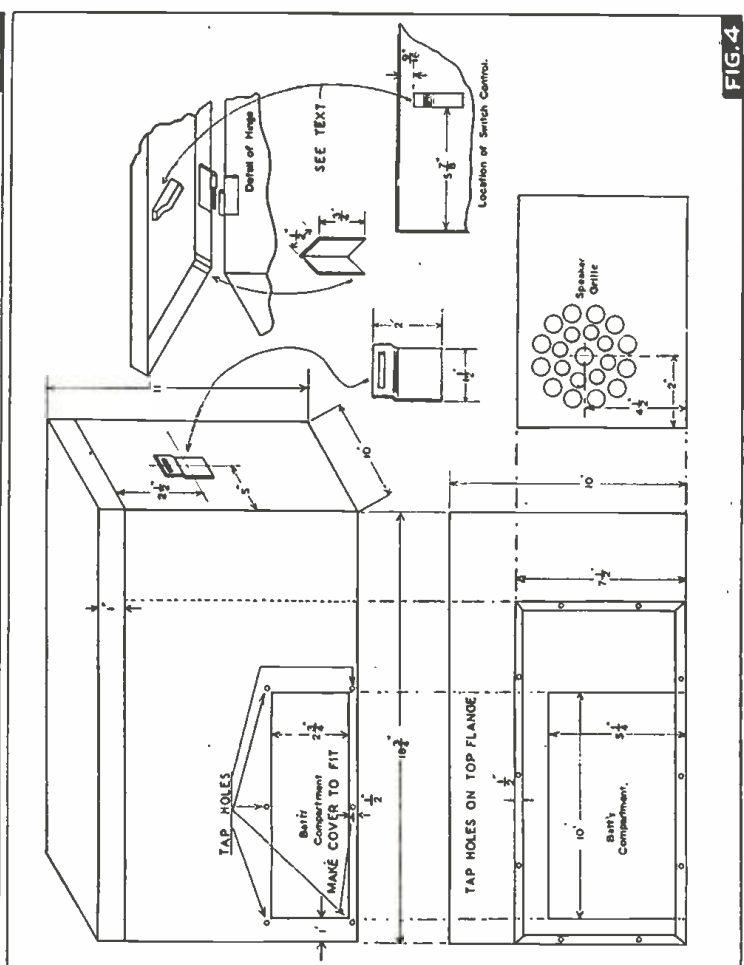

FIG. 4

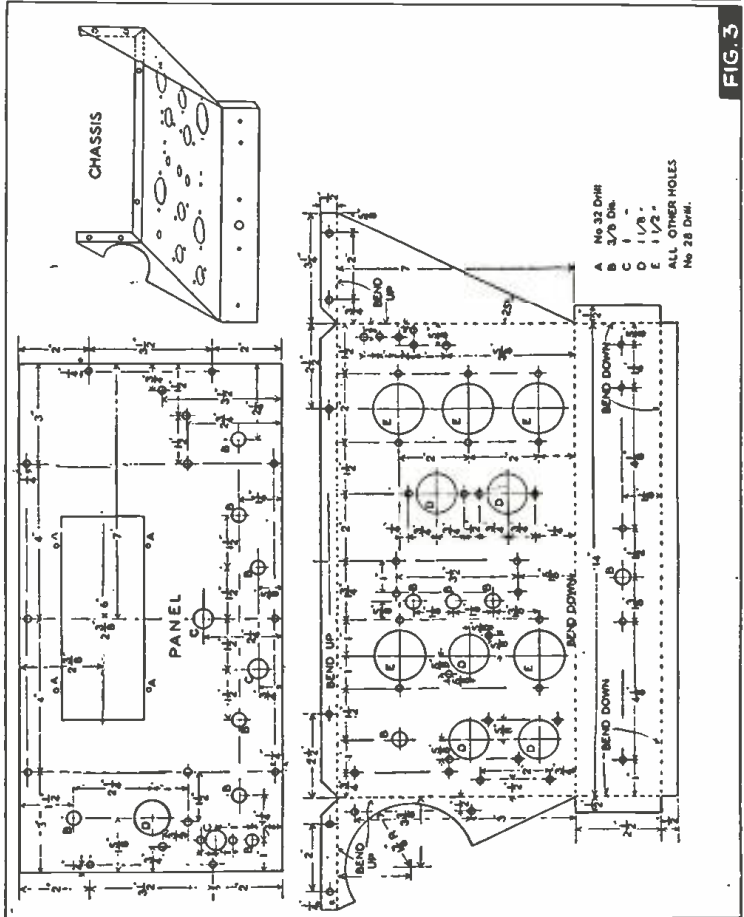
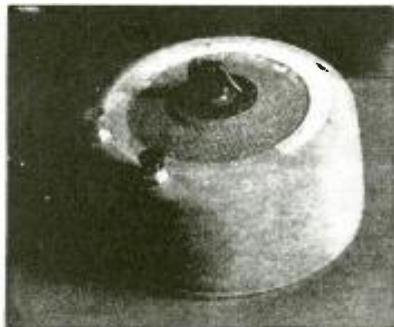

FIG. 3

This composite illustration shows the complete schematic circuit, parts placement, panel markings, drilling instructions and construction details of the Modern Interference Locator.







Model TBUA

## TALK-BAK\*

Talk-Bak\* intercommunication units provide complete versatility of operation.

- neat appearance
- rugged construction
- low initial cost
- low upkeep cost
- natural tone quality

Write for free bulletin

### WRIGHT-DECOSTER, Inc.

2251 University Ave., St. Paul, Minn.  
 Export Dept.: M. Simons & Son Co., New York  
 Cable Address: "Simonrice"  
 Canadian Representatives:  
 Wm. F. Kelly Co., 1207 Bay St., Toronto, Ontario  
 Taylor & Pearson, Ltd., Edmonton, Alberta  
 \*Copyrighted.

tor brush terminals of a small universal motor; and, the use of the exploring coil to measure the interference radiation intensity from a fluorescent lighting unit. The radiation field of this type of lamp may be appreciable at distances of 15 to 20 feet.

#### CONSTRUCTION DETAILS

Since there are a number of different input circuits to the interference locator, an untuned loop has been used. The loop is wound for the longwave band and is shunted with a loading coil for the 2 higher frequency bands.

**The Loop.**—This consists of 60 turns of No. 30 enameled copper wire wound on the loop frame—see illustration—and is center-tapped, with the center-tap grounded to obtain a balanced input. In winding the loop, the 2 diagonal members are attached to one of the side pieces and then the wire is wound in the end slots of the diagonal members.

After the loop has been wound the top, bottom and end pieces are attached. The loop jack plug is then bolted to the bottom piece and the leads soldered. The center-tap of the loop is connected to the long, or ground sleeve of the 3-circuit jack plug. The remaining side plate is then attached and the loop is complete, except for the bakelite adjusting rod, which is screwed into a tapped hole in the lower edge of the loop when the loop is used. All parts of the loop are fastened together using No. 4-40 flathead brass machine screws. This assembly design may be modified to suit individual tastes, however, iron or steel screws should not be used in the assembly. The loop, as designed, has adequate mechanical strength to withstand rough use without damage to the winding.

**The Exploring Coil.**—This unit is assem-

bled as shown in the illustration, and consists of a standard 1,500-turn honeycomb coil enclosed in a protective case made with 2 pieces of bakelite tubing and 2 bakelite discs or washers. The pieces are made to be a press fit and it is not necessary to use any assembly bolts. The exploring coil may be taped and varnished instead of using the assembly indicated; however, appearance is considerably improved if the coil is made as shown.

A 3-circuit jack plug and a phone cord extension complete the construction of the exploring coil. The ground sleeve terminal of the jack plug is not used, connection being made to the other 2 terminals.

**The Probes.**—The *line probe* consists of about 12 ft. of rubber-covered A.C. cord with a pair of phono-needle test probes at one end and a receptacle at the other end (see List of Parts).

The *single-wire test probe* is merely 8 or 10 feet of well-insulated single conductor wire with a phone tip-jack at one end and a test probe at the other. The test probes should be of the type having long insulated handles.

#### OUTPUT

Loudspeaker output of the Interference Locator is useful in making indoor checks and in preliminary adjustments of the loop antenna. Headphones, however, will be necessary for tests outdoors or in noisy locations, since the power output of the battery-operated output tube is not great enough to overcome high noise levels. The headphones used are of the high-impedance type and are preferably of the specified crystal type, although any type of high-impedance phones will give satisfactory results.

#### OPERATION

In connection with the operation of the loop antenna, it is well to remember that the signal will be at *minimum* when the plane of the loop is at right-angles to the direction of the signal. Thus minimum signal will be heard when the loop adjusting rod is pointing toward or away from the direction of the signal.

The sensitivity control should be adjusted so that a sharply-defined zero signal is obtained. Zero signal is used as it is easier to determine minute changes in sound level from a weak signal than from a loud signal. The sensitivity of the R.F. carrier meter is not great enough for accurate determination of direction and it cannot discriminate between the signal due to radio interference and one due to a radio station carrier or to background noise. The ear, of course, can make this discrimination.

One of the figures shows the top, bottom and front views of the Modern Interference Locator and may be used as a guide in the assembly and wiring of the receiver. The diagram shows that the type 1D8GT tube is used as the 2nd detector and 1st audio stage with the diode being used as the meter rectifier, otherwise the circuit is conventional. The illustrations which show details of the cabinet and chassis construction and are self-explanatory; so too are the details of the loop and exploring coil construction.

#### LIST OF PARTS

- COILS**  
 One J. W. Miller Co. type 628-A antenna coil;  
 One J. W. Miller Co. type 628-RF radio-frequency coil;  
 One J. W. Miller Co. type 628-C oscillator coil;  
 Two J. W. Miller Co. type 1112-C-2 I.F. transformers;

# JUST PUBLISHED!

A NEW BOOK TO ADD TO YOUR TECHNICAL LIBRARY

## AUTOMOBILE RADIO—Principles & Practice

by B. Baker Bryant



A COMPLETE compilation of pertinent data on how to install and service the modern automobile radio receiver. All of the non-essential details which have crept into the profession have been weeded out. Each topic is treated so as to contain a precise statement of the fundamental principle involved, to assure the reader's clear understanding of this principle, without distracting his attention by the discussion of a multitude of details and mathematical expressions, which are primarily for the engineer, and tend to confuse rather than clarify a statement for the auto-radio-technician. A practical treatise based on practical experience by practical radio people for the practical radio-technician.

#### Brief Outline of Contents—

- Introduction—The Auto-Radio Art.
- Features of the Modern Automobile Receiver.
- Installations of Automobile Radios and Antenna.
- The Automobile High and Low Tension Electrical Systems.
- Automobile Electrical Disturbances.
- Vibrator Converters and Motor Generators.
- Service Hints, Classified Automobile Installation Notes, and Conclusion.

Send 50c check, money order, unused U. S. stamps, or coin for your copy of "Automobile Radio—Principles & Practice"—it will be sent to you postpaid upon receipt of your remittance.

**RADCRAFT PUBLICATIONS, Inc.**  
 20 Vesey Street, New York, N. Y.

50c  
 POSTPAID  
 Size—6 x 9 inches  
 64 Pages  
 stiff, flexible covers  
 Numerous illustrations and diagrams



One J. W. Miller Co. type 4011 antenna loading coil;  
 One J. W. Miller Co. type 1612 honeycomb coil.

**FIXED CONDENSERS**

One P. R. Mallory Co. type 8-mf. electrolytic condenser 200 volt;  
 Eleven P. R. Mallory Co. type 0.1-mf., 400-volt condensers;  
 Four P. R. Mallory Co. type 0.05-mf., 400-volt condensers;  
 Three P. R. Mallory Co. type 0.01-mf., 400-volt condensers;  
 Three Solar type 0.003-mf. mica condensers;  
 Four Solar type 100 mmf. mica condensers;  
 One Solar type 10 mmf. mica condenser.

**\*RESISTORS**

One I.R.C. type 300 ohms;  
 Four I.R.C. type 5,000 ohms;  
 Four I.R.C. type 10,000 ohms;  
 One I.R.C. type 20,000 ohms;  
 One I.R.C. type 25,000 ohms;  
 One I.R.C. type 60,000 ohms;  
 One I.R.C. type 75,000 ohms;  
 Six I.R.C. type 0.1-meg.;  
 Three I.R.C. type 0.5-meg.;  
 Two I.R.C. type 1. meg.;  
 One I.R.C. type 1. meg. volume control.  
 \*All resistors type BT-½.

**TUBES**

Two RCA type 1N5-GT tubes;  
 One RCA type 1A7-GT tube;  
 One RCA type 1D8-GT tube;  
 One I.R.C. type 1Q5-GT tube.

**MISCELLANEOUS**

One J. W. Miller Co. type 2103 variable condenser;  
 Two J. W. Miller Co. type 205 2-pole, 5-position switches;  
 One J. W. Miller Co. type 605 band selector switch;  
 Four J. W. Miller Co. type 420 terminal plate;  
 Three J. W. Miller Co. type 1520 tie points;  
 Two J. W. Miller Co. type 1510 tie points;  
 One J. W. Miller Co. type 153 sliderule dial;  
 Four J. W. Miller Co. type 731 dial pointers;  
 One J. W. Miller Co. type 3093 dial knob;  
 One J. W. Miller Co. type 1740 shaft bushing;  
 One J. W. Miller Co. type 1721 antenna terminal;  
 Five J. W. Miller Co. type 1730 octal sockets;  
 One J. W. Miller Co. type 120-mm. oscillator pad condenser;  
 One J. W. Miller Co. type 400-mm. oscillator padding condenser;  
 One J. W. Miller Co. type 0.0016-mf. oscillator padding condenser;  
 One Yaxley 3-circuit phone jack;  
 One Yaxley circuit-opening phone jack;  
 Two Yaxley 3-circuit phone jack plugs;  
 One Yaxley 2-circuit phone jack plug;  
 One Amphenol type 61-F4 receptacle;  
 One Amphenol type 61-M standard plug;  
 One American Radio Hardware insulated phone tip-jack;  
 Three American Radio Hardware insulated test probes;  
 One American Radio Hardware phone-tip;  
 One Arrow Electric Co. 2-pole, single-throw toggle switch;  
 One Triplett type 326 0-100-microampere meter;  
 One Burgess type 6TA60 battery;  
 Cabinet, chassis, hardware, bakelite pieces, etc.

*This article has been prepared from data supplied by courtesy of J. W. Miller Co.*

# THE NEW DYNAROMETER

Features New Giant 8½" Double Jewelled Meter

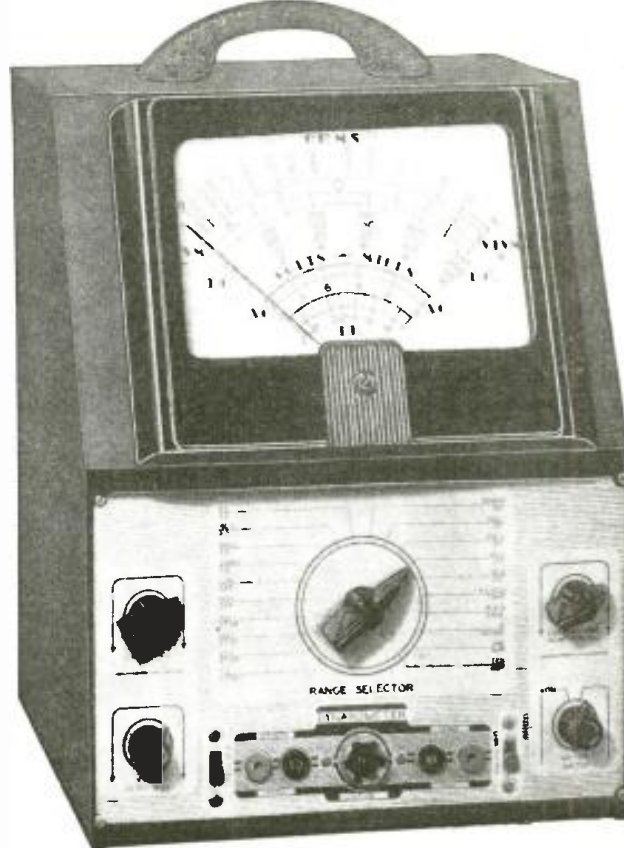

This amazing versatile instrument is our answer to the demands of radio-tricians for a combination instrument which, in addition to making the usual V. O. M. measurements, will also permit DYNAMIC D.C. VOLTAGE MEASUREMENTS without interfering with or upsetting delicately balanced circuits, such as tuned circuits, electronic apparatus, control voltages, etc. Actually, as you will note from the specifications listed below, the DYNAROMETER is a combination Vacuum-Tube Voltmeter and V.O.M. besides permitting additional measurements such as Capacity, Decibels, Inductance, etc. All calibrations printed in large, easy reading type on the giant 8½" double jewelled meter. The Input Impedance for the V.T.V.M. is

11,000,000 ohms with 2,000,000 ohms per volt on the lowest range. The 4 V.T.V.M. ranges are 5, 25, 100 and 500 Volts, and because of the zero center no attention need be paid to polarity since the meter will read either in the plus or minus direction, depending on the position of the probes.

**SPECIFICATIONS:**

4 D.C. VOLT RANGES AT 11 MEGOHMS INPUT: 0.5/25/100/500 Volts	D.C. CURRENT MEASUREMENTS IN 4 RANGES: 0-1, 0-10/100/1 Amp./10 Amp.
D.C. VOLTAGE MEASUREMENTS IN 5 RANGES: (at 1000 ohms per volt) 0-10/50/250/500/5000 Volts	4 OUTPUT RANGES: 0-15/150/1500/3000 Volts
A.C. VOLTAGE MEASUREMENTS IN 4 RANGES: (at approximately 800 ohms per volt) 0-15/150/1500/3000 Volts	2 CAPACITY RANGES: .0005-1 Mfd. .05-100 Mfd.
RESISTANCE MEASUREMENTS IN 3 RANGES: 0-1,000 Ohms, 0-10,000 Ohms, 0-30 Megohms.	INDUCTANCE: 1 H.-70 H. 7 H.-10,000 H.

The Dynarometer operates on 90-120 Volts 60 cycles A.C. Comes complete with test leads and all necessary instructions. Shipping weight 20 lbs. Size 13½"x10"x8¾". Our net price **\$18<sup>75</sup>**

**SUPERIOR INSTRUMENTS CO.** 136 Liberty St., Dept. RC-1  
 NEW YORK, N. Y.

**WHAT STRANGE POWERS**  
 Did The Ancients Possess?  
 WHERE was the source of knowledge that made it possible for the ancients to perform miracles? These wise men of the past knew the mysteries of life and personal power. This wisdom is not lost—it is withheld from the masses. It is offered freely TO YOU, if you have an open mind. Write for free sealed book. Address: SCRIBER, B.B.  
 The ROSICRUCIANS  
 San Jose (AMORC) California

**PATENTS—TRADE MARKS**  
 Booklet concerning Inventions & Patents Form "Evidence of Conception" with instructions for use and "Schedule of Government and Attorneys Fees"—FREE  
**LANCASTER, ALLWINE & ROMMEL**  
 Registered Patent Attorneys  
 436 Bowen Bldg. Washington, D. C.

**FLIGHT**  
 THE PICTORIAL FLYING REVIEW  
 Brings you all the phases of world aviation and aeronautics in a non-technical yet educational manner—exciting articles which catch your breath, yet give you the fundamentals of flying and ALL related subjects. FLIGHT keeps you abreast of all the major developments as fast as they appear anywhere.  
 Now, when planes and flying are of vital importance to all, you just can't do without this highly absorbing yet instructive publication. You must be "in the know."  
 Attractive three-color cover, numerous illustrations. **15¢** copy  
 Partial Contents of the January Issue: Inside a Bomber on the Attack. Aerial Troop Trailers. Air Battle "Sky Writing". Dive, Altitude and Attack Bombing. Anti-Aircraft Defense. Searchlights—the Curse of the Night Bomber. How R.A.F. Fighting Planes Attack German Bombers. England's Air Raid Precautions. How German Bombers Dive Through Smoke Rings. Barrage Balloons.  
**FLIGHT MAGAZINE**  
 20-R Vesey St., New York, N.Y. Subscription price \$1.50 a year, Canada and foreign \$2.00.

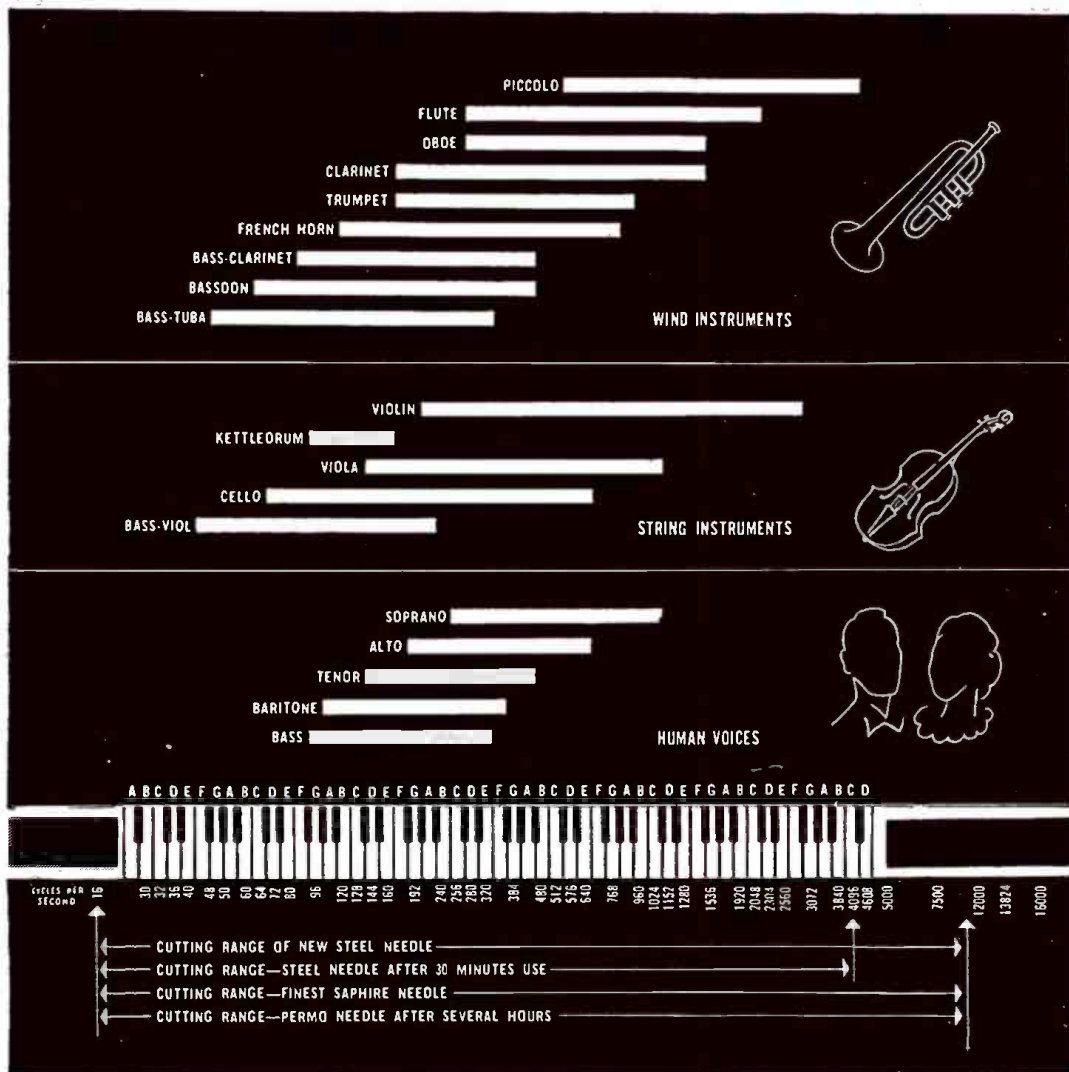

Fig. 1. This Audible Spectrum chart shows the relation of the frequency range of the vibrations generated by various musical instruments and human voices. Frequencies are always expressed in cycles per second. This gives a basis for comparison of different tones. This chart also graphically shows the efficiency range of various cutting needles. Note that as the cutting edge of the needle wears, its ability, or efficiency, to record drops rapidly.

## RECORDING POINTERS

*In presenting "Recording Pointers" Radio-Craft breaks its usual rule not to present material generally available in printed form. In view of the widespread interest in Sound Recording, however, we here reprint an exceptionally concise and informative article, on sound-recording procedure, of interest to Servicemen and other technicians.*

THE layman and even the technician will no doubt be confronted with various problems in making records at home or at different locations, particularly when the instrument is new and the novelty of recording is fascinating.

Before starting to make a recording, make sure that the cutting needle is in good shape, which may be tested by cutting a few grooves on an unused section of a discarded record. Also make sure the needle set-screw is tightened inasmuch as a loose needle will cause a loss of tone quality, especially in the high-frequency bands.

### TONE QUALITY

The quality of the recording can oftentimes be improved when the tone controls of the recorder are set in the "high" position. However, some recorders are not equipped with variable tone controls. On the other hand, too many "highs" may cause the recording to sound "squeaky" or shrill, but experience will soon show the most optimum position for the tone control according to various pick-ups; that is, whether orchestra, solo singer, piano, etc. A quick way of testing the system when using a microphone is to jingle keys in front

of the microphone and make a test cut. This will give a quick check on the fidelity of the system due to the various types of vibrations being emitted by the jingling keys on a key ring. This may require practice.

A few suggestions may be helpful in pointing out various factors on influencing the layman's recordings. For instance, it is quite common to record piano numbers on home recording instruments, and invariably this instrument is either used to record the accomplishments of the student or at parties in a spirit of conviviality. Piano recordings may at first be disappointing inasmuch as this is one of the most difficult instruments to make sound natural on ordinary recording equipment. Since the location of the piano in the room, surrounding acoustics, and placement of the microphone will directly affect the quality of a piano recording, it should be pointed out that improvement may sometimes be had by shifting the microphone around. As a rough guide,

when picking up sound from an upright piano, it may be more practical to place the microphone 4 or 5 feet diagonally from the treble, or high, keys of the keyboard. This distance will naturally depend upon the acoustics in the room and recorder sensitivity, and the technician should try moving the microphone about in this general direction.

When recording baby grand pianos, it has been found highly practical to open the top and place the microphone 6 to 8 feet from the treble, or high, end on the keyboard. The actual distance of the microphone from the piano will be determined more closely by the over all gain, or sensitivity, in the recording system. Usually there is an optimum point which will pick up the approximate correct tone quality, which is complicated in the case of a piano because of the various harmonics emitted from the vibrating strings and sounding board. At different microphone locations, the various



# Home Recorder FREE!



**FACTORY-TO-YOU SAVES UP TO 50%**

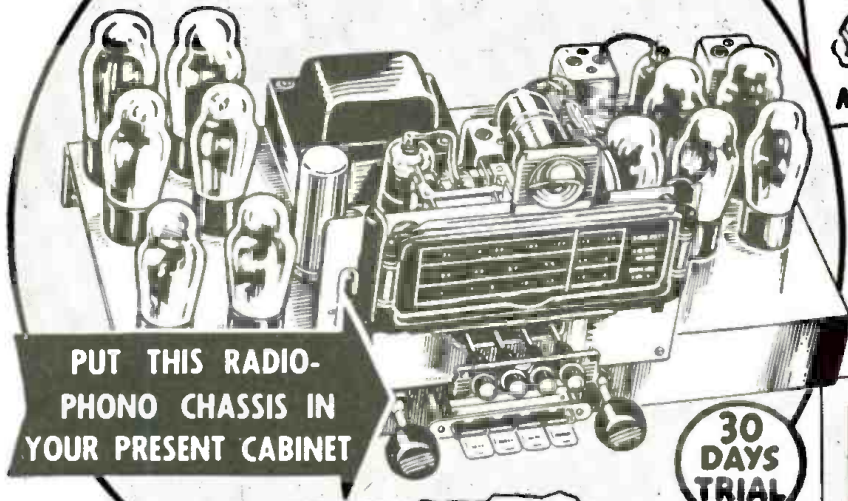

**PUT THIS RADIO-PHONO CHASSIS IN YOUR PRESENT CABINET**

**30 DAYS TRIAL**

**THRILLING WORLD-WIDE FOREIGN NEWS DIRECT!**



**MAKE RECORDS AT HOME**



**SELF-STARTING ELECTRIC-PHONO**

**UP TO \$25 TRADE-IN ON YOUR OLD RADIO OR CHASSIS** (on Many Models) (up to 18 Tubes)

**YOU'LL** enjoy listening to fine recordings on this new-type electric phonograph, and you'll be delighted with this amazing, ocean-spanning radio. Make your own records on the Home Recorder (sent FREE for a limited time) with this Radio-Phono



Combination. Big FREE catalog pictures many beautiful 1941 Factory-To-You radio chassis and console values—from 6 to 18 tubes—up to 5 bands—including Automatic Record-Changing, Radio-Phonographs, Home Recorder, etc. Get our **LIBERAL TRADE-IN PLAN**, and 30-day Home Trial offer. Easy Terms! Write for FREE catalog today.

*Local Service: An authorized Midwest Service Man is located near you. He is capable of giving you prompt and efficient home service—and supplying genuine Midwest parts.*

**EASY TERMS**

**15-TUBE MIDWEST RADIO-PHONO COMBINATION**

with **FREQUENCY MODULATION** and **TELEVISION ADAPTATION**

**ONLY \$22<sup>50</sup> RADIO-PHONO CHASSIS with TUBES and SPEAKER COMPLETE**

**HOME RECORDER FREE**

**15-TUBE TILT-FRONT**

**CABINET MODEL RADIO-PHONO COMBINATION**

**\$29<sup>95</sup> COMPLETE**



**FILL IN COUPON AND MAIL TODAY OR JUST SEND YOUR NAME AND ADDRESS ON 16 POSTCARD**

**MIDWEST *Factory-to-You* RADIOS**

MANUFACTURERS OF QUALITY RADIOS SINCE 1920

Midwest Radio Corporation  
Cincinnati, Ohio, U.S.A.  
Dept. 12-EE

Send me your new FREE Catalog, complete details of your liberal 30-day Trial offer and factory-to-you prices.

Name.....

Address.....

Town..... State.....

User-Agents Make Easy Extra Money. Check here ( ) for details.



Fig. A



Fig. B



Fig. C



Fig. D

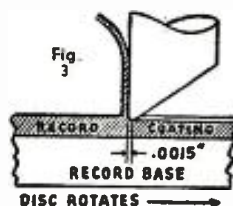

harmonics will sometimes appear in different magnitude because of the acoustics or resonance in the room.

In recording sound from such instruments as the accordion, it should be remembered that this instrument emits almost pure sine-wave tones, and the microphone should not be placed too close because of the surprising acoustical carrying power of the tones. If the microphone is placed too close to the accordion, over-loading of the recording system may occur, in which the record may sound distorted. Some of the tones may not be clear or if another instrument or singer is accompanying the accordion, it may be found that the "blend" or "balance" is not correct because of too much accordion, in which case it should be placed farther in the background of the mike pick-up. Also, on brass wind instruments, such as cornets, trombones, etc., do not place the microphone too close to these instruments for best results. In many cases, the gain, or sensitivity, of the entire recording equipment may govern the actual distance the microphone should be placed from the instruments, but with average sensitivity, the recording may be over-loaded when the instruments are too close to the microphone.

On such instruments as violins, moderate distance from the microphone should prove practical, but care should be exercised so that the bow noise is not picked up.

On percussion instruments, such as drums, bass fiddles, etc., these instruments will emit low-frequency sound waves, which have considerable amplitude and may over-modulate the record groove. If this occurs, an echo of the passage of music may be heard in the recording.

Too much amplitude or "sound level" can cause "echo" which is due directly to "plasticity" of the coating material; i.e., the material is soft and is somewhat displaced by the cutting needle action when there is not enough "land" or distance between the grooves. This causes "echo" or repetition of the sound in the next groove and is not to be confused with acoustical echo in the room. Do not place the microphone very close to such instruments as drums. With highly sensitive equipment, it has sometimes been necessary to place a coat, or cloth, over the front of the drum next to the microphone so that too much of the low-frequency sound would not strike the microphone directly. These factors, of course, will all be influenced by the acoustics of the room, etc. It may also be noticed that the system can be overloaded by placing the bass fiddle too close to the microphone, especially when the strings are plucked.

#### MORE ON MIKE TECHNIQUE

It is difficult to make quality recordings in such places as school rooms or other locations where the acoustics are very poor. It has been found very practical to open the windows in such places to minimize the effect of the room echo.

In making records in large halls and auditoriums, which usually do not have very good acoustics for recording, it may be found feasible to suspend the microphone from the ceiling near the first curtain drop

over the stage. In many locations, this may be an optimum location to minimize the pick-up of the "slap", or sound echo, in the hall.

In recording quartets, and so on, usually the soprano voices will record more loudly than the bass voices. Therefore, it is sometimes advisable to place the microphone somewhat closer to the bass singers, all persons being grouped in a semi-circle. In general, it is not advisable to have solo singers too close to the microphone because in most cases they are not familiar enough with microphone technique and on loud passages may over-load the recorder system so that distortion will be had in the recording. Do not hold or fumble with the microphone when singing, etc., as this will cause superfluous noises to be recorded. Speaking too close to the mike may make your recordings sound "boomy".

#### TURNTABLE TIPS

In making records of radio programs, the recording may not sound as brilliant and clear as it should, and if the entire equipment is adjusted properly and the cutting stylus is not at fault, some improvements can often be made by slightly detuning the set; that is, turning the station tuning knob a trifle off the exact location or actual number on the dial at which this station is usually tuned-in.

Sometimes it may be noticed, especially with piano or organ recordings, that there are "wows" or slight wavering of the music when the record is being played. This is usually caused from a varying turntable speed and sometimes is very difficult to eliminate entirely. Oftentimes, when the recorder is first turned on, the turntable motor may be slightly off in speed, and in cases like this sufficient time should be allowed for the recorder to warm up before a recording is made.

In order to get the most out of your recording equipment, carefully set the control knobs according to the manufacturer's recommendations and make sure that you have a good cutting stylus. Above all, *make certain* that you have a high-quality playback needle when you wish to listen to the recording. Excellent recordings have been ruined and cannot sound natural when the wrong type or misfitting phonograph needles are used to play the record. It is false economy to use cheap phonograph needles when one is interested in listening to records which are an investment in recreation or talent.

#### RECORDING NEEDLE

Assuming that the recording equipment is in proper electrical and mechanical adjustment, one of the most important factors in making good recordings is in the recording, or cutting, needle itself. Although only about three-thousandths (0.003-in.) of the tip of a recording needle is actually used in engraving the blank record, the accuracy of the tip must be controlled to precise standards for best results.

In Fig. 2 is shown a cross-sectional view of a record groove magnified 150 times. To give best life and coordinated performance, the dimensions of this groove must be kept

uniform, inasmuch as the phonograph playback needle tip is precisely ground and in a quality needle has a true and correct radius to properly fit this standard groove. If the tip of the cutting needle wears rapidly, then the outside, or beginning, grooves of the record will be of different shape and dimensions than the innermost, or final, grooves of the recording. This means the recording may be distorted, will not sound natural, will have poor tone quality, and, because the playback needle does not properly fit the groove, the number of times the record may be played will be definitely limited. The engraving, or cutting, of a record groove consists in generating a spiral groove with a stylus on a coated disc and, as can be seen from the drawing, the dimensions are quite minute. With home-type recording equipment, which cuts an average of 100 grooves to the inch, and for a 10-inch record, the total length of the spiral groove from beginning to end will be about 590 ft. long. One can, therefore, see that considerable work is done by the cutting stylus on only one record face.

Because the recording needle is constantly modulating the groove it cuts—in other words causing the groove to waver back and forth as the record spins around—tremendous strain is placed upon the cutting edges and "nose," or tip, of the needle. If these edges are properly ground and a clean cut is made, the amount of "surface," or background, noise in the groove will be minimized inasmuch as the coated material is severed properly. Some discs may be more quiet than others, but if the needle cutting edges are dull, then the action is more or less tearing of the disc material in the groove and the background noise is naturally much greater.

Likewise, the high-frequency modulation will not be registered properly because a dull cutting edge cannot efficiently cut the small undulations, which occur at an exceedingly rapid rate. The distance of the humps in the vibration wave of a high piccolo tone, which is about 5,000 cycles per second (see Fig. 1), is about 0.0015-in. at the middle section of the record when recorded at 78 r.p.m. It can be seen, therefore, that the needle vibrates back and forth at such a rapid rate that unless the cutting edge is sharp, there is insufficient time and the distance is so small that it is impossible to record, or register, the high frequencies properly. The "high frequencies" give naturalness and timbre to a recording (see Fig. 1).

Another reason the cutting stylus should remain sharp is because the coating material on a blank record is somewhat plastic and will "flow" or be pushed over instead of being "cut" if the edges of the cutting needle are dull. This results in recordings lacking in "highs" and may sound "bassy" or distorted.

A recording which is deficient in the upper frequencies will not sound brilliant and

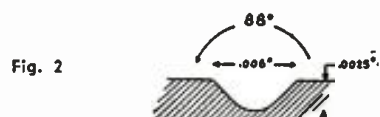

Fig. 2



clear and if many of the "high frequencies" are cut off, the recording may become "mushy," too "bassy," and distorted. Steel cutting needles do not have a radius on the tip, and because there is terrific pressure at the very tip equivalent to about 20 tons per sq. in., the steel cutting edge wears extremely fast. Shown in Fig. A is an actual photograph of a high-grade new steel needle. Note that it can cut only a V-groove.

After a few minutes' use, due to abrasive action, friction, and extreme pressure on the cutting edges of the steel needle, the point rapidly wears down, and it can be easily seen from the photomicrograph shown in Fig. B, that the groove it will now make is entirely different in character than when originally started. Dulling of the point and leading edges cause an increase in background, or surface, noise. Likewise, as the tip becomes more dull, the ability to properly engrave the blank is greatly reduced.

The photograph in Fig. C shows approximately 30 minutes' use of the same steel needle on a nitrate recording blank, which is a very soft material. Note how the tip has worn very jagged and irregular.

In Fig. D is a photomicrograph of the tip of an alloy recording needle. Because this needle is made with a special alloy which is wear-resisting, it is possible to obtain hours of use before the tip and cutting edges are dulled to the extent that the recording is noticeably affected. With this needle, the sharp cutting edges properly sever the material with a minimum amount of noise being generated, and because the alloy tip is very rugged, it will withstand considerable abuse in the hands of the layman. Nevertheless, it is always advisable to never let the recording head down on a blank disc unless the disc is rotating. This applies to any cutting stylus.

The alloy recording needle (known in the trade as "Permo Point") usually cuts much quieter than the steel needle because of its wear-resisting qualities, and because the tip is ground with the proper radius and polished, the recorded groove is of uniform shape. Because wear is minimized, the recorded efficiency of the high frequencies is tremendously increased so that the tool is fully the equivalent of sapphire or any other cutting tool. It is possible to record frequencies as high as the recording head and associated equipment is capable of handling. This means brilliance, cleanliness, and naturalness in the sound of the recording on playback.

**SHAVINGS**

This drawing shows the average position of a needle when cutting a blank record correctly. Note the extremely small distance which exists when cutting a 5,000-cycle note (equivalent to the highest number of vibrations of a piccolo or violin). It is easily seen that the cutting edge of the needle must remain extremely sharp to efficiently record the various tones of such instruments.

Ordinarily, the amount of shaving cut from the blank record ranges approximately three to five thousandths inch (0.003- to 0.005-in.) in thickness, depending upon the sharpness of the cutting tool, cutting head pressure or weight and hardness of the record material. If for any reason the cutting head pressure is altered or changed, do not readjust so that the shaving is any greater than 0.003- to 0.005-in. for best results. This is slightly thicker than the average human hair. If too light a thread, or shaving, is cut, it will be hard for the cutting needle to follow a warped or uneven record surface. On the other hand, if the shaving is extremely heavy, the cutting needle may cut clear through the

**Tok Fone 15 WATT A. C. AMPLIFIER**  
**AT A PRICE LESS THAN YOU'D PAY FOR THE PARTS ALONE!**



ONLY Tok Fone WOULD DARE OFFER SUCH AN AMAZING VALUE!

**\$ 9 75**  
 FOR AMPLIFIER LESS TUBES F. O. B. N. Y. Kit of matched tubes add \$4.50

**FEATURE BY FEATURE IT'S PACKED WITH VALUE!**

Unlike some manufacturers who use old-fashioned mathematics to compute "cost, plus sales expense, plus this, plus that, plus profit—equals net selling price"—TOKFONE uses short cut arithmetic and says: "Buy direct from the manufacturer at ONE SMALL PROFIT at a LOW NET PRICE!" This 15 watt A.C. Amplifier is typical of our way of selling to meet TODAY'S MARKET. Check each feature and you'll agree that value is not wanting!

- EXTRA HEAVY CHASSIS
- COMPLETELY SHIELDED
- ALL OVERSIZED COMPONENTS
- SIX TUBE CLASS A PUSH-PULL
- THREE INPUT POSITIONS  
2 Microphone, 1 Phono Input
- 2-4-8-5000 OHM OUTPUTS
- HIGH GAIN, WIDE FREQUENCY RESPONSE
- FIFTEEN WATT OUTPUT
- CONTINUOUS, VARIABLE TONE CONTROL
- FOUR STAGES OF AMPLIFICATION
- TUBE LINEUP: 1-6S17, 2-5C7, 2-6N6, 1-83V
- OPERATION ON 110-120 VOLTS, 50-60 CYCLE
- LIST PRICE \$24.50—If screen is desired, add \$2.25

This job will operate from 1 to 20 speakers from a crystal mike. Has individual volume controls for phonograph and microphone and also tone control. It's America's best, buy whether you buy only the amplifier or the complete system.

**MANY OTHER EQUALLY GOOD TOKFONE BUYS**

30 Watt AMPLIFIER	List 67.50	Your Cost \$26.95
30 Watt BOOSTER	List 38.95	Your Cost \$17.50
60 Watt AMPLIFIER	List 82.50	Your Cost \$32.95
60 Watt BOOSTER	List 52.95	Your Cost \$23.50
15 Watt Portable Amplifier In Case	List 49.50	Your Cost \$24.00

Get our Descriptive Literature and Price List. Also complete line of Recorders, Record Players, etc.

**INVESTIGATE — THEN INVEST IN THIS Complete ALL-PURPOSE SOUND SYSTEM**

15 Watt Amplifier as Described	LIST PRICE \$24.50
2 12" Speakers @ 7.50 each	15.00
2 Wooden Speaker Baffles @ 10.00 each	20.00
1 Crystal Microphone with Desk Stand	12.50
1 Kit of 6 Matched Tubes	9.30
<b>TOTAL</b>	<b>\$81.30</b>

**YOUR COST \$32.50 NET**  
 add \$2.25 if screen is desired

**Tok Fone REGAL AMPLIFIER MFG. CO.**  
 14 WEST 17th ST., NEW YORK, N. Y.

coating material. This will result in dulling the needle and in general cause a decrease in the quality of the recorded sound.

The alloy cutting needle is properly ground to operate in conjunction with the surface tension of the recording blank so that as the shaving is cut, it tends to jump toward the center of the record. If trouble is experienced with shavings catching on the needle or if they are not properly thrown inward, loosen the thumb set-screw and rotate the needle slightly so that when the screw is again tightened, the face of the cutting needle is not quite at right-angles to the grooves. This turning amounts to only 1 or 2 deg., but usually permits the severed shaving enough clearance to allow it to jump towards the center.

This article has been prepared from data supplied by courtesy of Permo Products Corp.

See Page 422 for the latest book on Auto Radio

**NEW AUDIOGRAPH Sound Catalog**

AUDIOGRAPH Sound Systems represent the latest in Sound Engineering and Design—a complete line plus pre-tested accessories.

**NEW LOWER PRICES**

Outstanding quality and performance at prices that help you meet any competition.

**WRITE FOR FREE COPY**  
**JOHN NECK INDUSTRIES**  
 1313 W. Randolph St., Chicago, Ill.

# SOUND ENGINEERING

Free Design and Advisory Service

For Radio-Craft Subscribers

Conducted by A. C. SHANEY

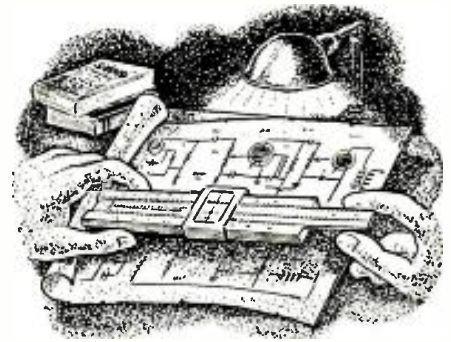

This department is being conducted for the benefit of RADIO-CRAFT subscribers. All design, engineering, or theoretical questions relative to P.A. installations, sound equipment, audio amplifier design, etc., will be answered in this section. (Note: when questions refer to circuit diagrams published in past issues of technical literature, the original, or a copy of the circuit should be supplied in order to facilitate reply.)

No. 13

## A PHOTOCELL PREAMPLIFIER WITH HIGH-FREQUENCY EQUALIZER

### The Question . . .

I would have had you design a special amplifier for picture sound work, only the Government has imposed restrictions and we can not import such parts. I have built such an amplifier which works 100% except for the preamplifiers. These are two 6J7s. I have a jack fitted between the 6N7 and the preamplifiers for phono work. Now, I want you to publish a circuit in *Radio-Craft* for a high-quality preamplifier for photocell connection. I would like to use the 6SJ7 tube which has the grid on the bottom.

Please design this photocell preamp. with sufficient gain to drive my amplifier. Sometimes we have a very low level film recording and need plenty of gain. I would like you to insert a frequency control in the preamp. for high-frequency response. Is this feasible in an amplifier for theatre work? I have tested the amplifier with the oscilloscope and it's a great job. I have tried all ways to improve the preamps. They work OK except for a noise which comes in now and again.

I will discard my present preamplifier if you will design one for me using either 2 tubes, or 3, or whatever you think best. Give me the diagram in *Radio-Craft*, showing how to connect on to the amplifier

diagram enclosed (shown here). Is it better to have the preamp. separate from the main amplifier and not on the same chassis?

You will notice a potentiometer on the preamps. It's a 1 meg. unit which adjusts the P.E. cell voltage. I don't like that as I have tested several and they are noisy on headphones. In photocell work, you want no noise at all. I want the last thing in a preamp. for P.E. cell work with polarizing voltage, etc. One side grounded for P.E. cell is the usual standard. What do you think?

I will be waiting for that *Radio-Craft* to come. Carry on with the good work. Mr. Shaney.

J. CHAPMAN,  
Chapman's Pictures,  
Waiuta, South Island,  
New Zealand.

P.S. The diagram as indicated in Fig. 1 is my present photocell circuit. You will notice that the negative side of P.E. cell is not grounded. A very peculiar noise starts sometimes like a small whistle and then a scratchy noise, and then it disappears.

### The Answer . . .

I am surprised that your present pre-amplifier works at all. Unless you have made a mistake in the diagram that you sent along, it appears as though there is no negative return for the photocell. Frankly, I can not see how the photocell could pos-

sibly work unless you have some leakage through the 0.1-mf. condenser into ground. If this is so, then it will account for the intermittent, scratchy noise and whistle.

Another possible source for noise would be the 1-meg. variable voltage supply. If you are using a carbon type of control, there is a strong possibility that a variable contact is made at any fixed setting. In order to avoid this condition, an additional series resistor should be employed with an appropriate bypass condenser, so as to bypass any variations in contact potential.

You will note that the dual-channel photocell circuit of Fig. 2 employs straightforward design. A single equalizer is inserted at its output so as to provide both accentuation and attenuation of the high frequencies. The 6SJ7s (pentodes) are used as preamplifiers and the 6SJ7 triode is used as a voltage amplifier.

The advisability of having a high-frequency equalizer in a photocell circuit has received a considerable amount of attention from sound motion picture engineers. It is generally conceded that unless the film is brand new and made with new noiseless recording systems, high-frequency accentuation would be undesirable. It has been found in actual practice that high-frequency attenuation is generally preferred, as this appears to eliminate a large portion of objectionable film noise.

Unless the complete amplifier is carefully co-ordinated, in its original design, it is usually best to separate the preamplifier from the power amplifier, as less precautions will be required to avoid excessive hum. You will note that 2 independent controls are provided for supplying voltage to each of your photocells. This will enable you to balance any variations between cells.

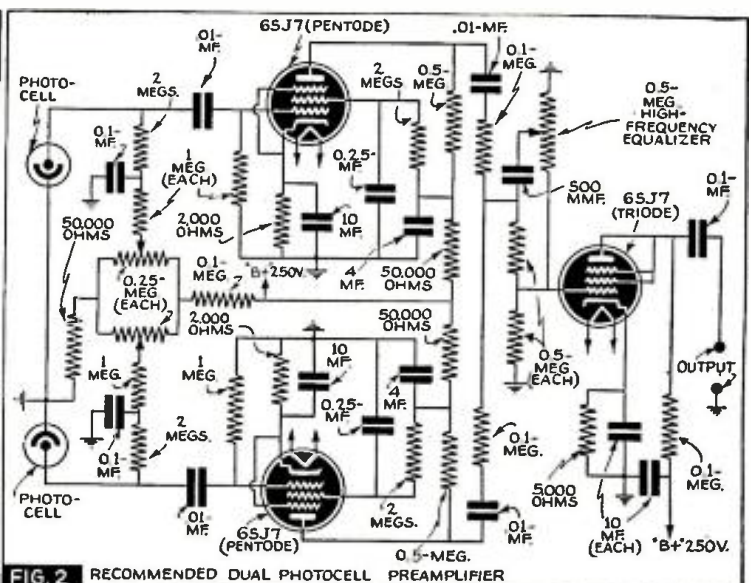
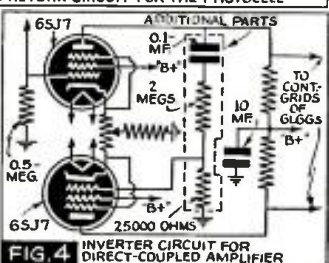
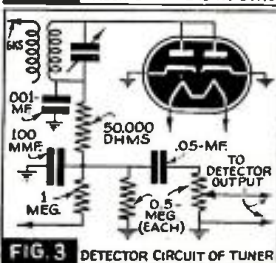
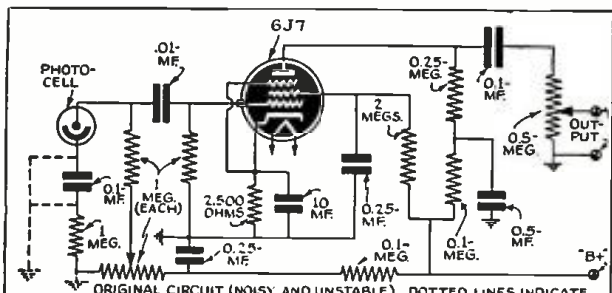



CONNECTING A RADIO TUNER TO A DIRECT-COUPLED AMPLIFIER

The Question . . .

I have just acquired a tuner for a detector circuit as indicated (see Fig. 3). I want to use this tuner in conjunction with a 10-watt direct-coupled amplifier described in a past issue of *Radio-Craft*. I am enclosing a copy of the diagram of the detector circuit with the 1st audio amplifier. I want to connect the push-pull input of the amplifier direct to the detector. The 1st audio can be disconnected from the circuit.

JUAN CARBALLO,  
Jaro, Iloilo,  
Philippines.

The Answer . . .

The easiest way to connect the single-ended output of your tuner to the amplifier is to revise the amplifier input circuit for inversion, as indicated in Fig. 4. This will provide a push-pull signal to the grids of the output stage, and will avoid making any changes in the detector circuit of your tuner.

If you have one of the original direct-coupled amplifiers, it may be necessary to add an additional 10 mf. filter condenser at the junction of the plate supply and resistors of the 1st stage. The newer models have a built-in switch which automatically changes the input circuit from single-ended to push-pull. This latter amplifier will not require any circuit changes whatsoever.

WHY THE SUPERHETERODYNE?

WHY the superheterodyne? Is converter tube hiss something we should like? Is sideband cutting desirable? Are the trick alignment adjustments really necessary for getting results when a simpler, though somewhat bulkier, tuned radio frequency job would give these advantages: less noise, no code interference, high-fidelity sideband response, adequate selectivity and sensitivity less critical alignment—with no special apparatus needed—why the trouble-some super.?

A suitable line-up would be: 6K7 1st R.F., 6K7 2nd R.F., 6J7 power detector, 6C5 1st A.F., 25L6G output, and 25Z5 rectifier with a set equipped with a 12-inch speaker. The audio amplifier would have negative feedback from voice coil to 6C5 grid-return for flat response. There would be a smooth-action volume control in the cathodes of the 6K7 tubes and antenna input circuit, and no A.V.C. (and no A.V.C. troubles). The set would then be quiet in-between stations. The dial would have an accurate kilocycle calibration, easily read, accurately built, with ruggedness the key-note. For dropping the line voltage, there would be a heavy-duty resistor, not a flimsy ballast tube. All parts would be of good quality and the entire set designed to last for 10 years, not 2 as is present design practice.

Manufacturers get busy—give the long-suffering public a break. Make tubes that last a year, gosh we'll be thankful! Or are we too optimistic?

WILLARD MOODY,  
New York, N. Y.

"MICROPHONE TECHNIQUE"

Scheduled to start in this issue of *Radio-Craft*, it has been found necessary to start this series of special articles on the use of the various types of microphones in the February issue, instead.

NEW FM AUDIO AMPLIFIERS

Designed by A. C. Shaney

FREQUENCY RANGE: 13-30,000 c.p.s. ±1 db  
POWER RANGE: 0.003 to 30,000 Milliwatts  
MUSICAL RANGE: 11 Octaves  
DYNAMIC RANGE: 80 db

Outstanding in their performance, construction, and appearance. These amplifiers were specifically designed for use with frequency modulation tuners, standard amplitude modulation receivers, and absolute fidelity phono reproducers. Load by a wide margin the very finest resistance, impedance or transformer-coupled amplifiers. Incorporate two basic AC and DC balancing circuits (Pat. app. for) which provide greater circuit stability than conventional amplifiers.

Guaranteed for FIVE YEARS

Write for literature describing our FM Amplifiers

AMPLIFIER CO. of AMERICA

17 WEST 20th STREET NEW YORK, N. Y.

DATAPRINTS

TESLA-LOUDIN COILS  
20c Ea. in order for 10 (Data and Drawings only.)  
36" Sp'k Tesla-Oudin Coil 40c  
(1 K.W. Exc. Trf. Data incl.)  
8" Sp'k Tesla-Oudin Coil 40c  
(1/4 K.W. Exc. Trf. Data incl.)  
8" Sp'k Oudin; 110 Vt.  
"Kick Coil" type.....40c  
3" Tesla Works on Ford Coil .....40c  
1" Sp'k Vibrator Hi-Freq. Coil 40c  
NEW! 5 ft. Sp'k. Oudin Coil & Exciter Data .....75c

Induction PIPE & ORE LOCATOR  
Induction Type, Data .....40c  
Radio Type .....40c

More DATAPRINTS 40c each!

5 Meter Superhet.	Electric Refrigerator
1/2 Meter Tr. & Rec.	Whetstone Bridge
20 A.C. Probs. & Ans.	Weld. Transf. 2 K.W.
20 Telephone Hook-ups	Rewinding Armatures
100 Mech. Movements	String Galvanometer
20 Motor Hook-ups	20 Simple Bell Circuits
Television Hook-up	Steel Wire Recorder!
20 Elec. Party Tricks	Water Wheels or Turbines
Solenoids and Magnets —get list.	Photo Cell and Relay
Fry Eggs on Ice!	Ring 4 bells: 2 Wires
Experimental Photophone	20 Tesla Tricks
Radio Control for Models	Polarized Relay
Diathermy Apparatus	Induction Balance
Inductor Organ	Electric Pipe Thawer

Special Prices: 4 prints \$1.00; 10 for \$2.00; Single, 40c each. Get New Catalog 100 A.

The DATAPRINT Co.

Lock Box 322C, Ramsey, N. J.

TURNER Microphones  
Write for free new literature to  
The TURNER CO. Cedar Rapids, Iowa  
Credits licensed under patent Bush Development Co.

FILMGRAPH VOICE AND MUSIC RECORDINGS

Lengthy or continuous recordings now possible with newly patented "FILMGRAPH". Over 13 hours of indexed voice, radio, code, telephone recording on a single 500 ft. reel of film costing \$3.00 and up. No other expense. INSTANTANEOUS and PERMANENT play-back. Can easily be synchronized with Motion pictures. Bulletins free.

MILES REPRODUCER CO., INC. Dept. RCB, 812 Broadway, New York City

IT PAYS TO USE THE BEST!  
University's "Non-Resonant" high efficiency "Reflex" Loudspeakers will always prove most economical in the long run.  
UNIVERSITY LABORATORIES  
195 Chrystie St. New York City

ONLY \$4.96 U. S. NAVY AIRPLANE-TYPE

Microphone and Receiver

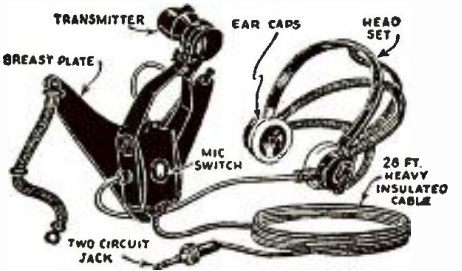

THIS Microphone and telephone headset outfit was built especially for the U.S. Navy Aviation Corps for Plane-to-Plane and Plane-to-Ground communication.

The Holtzer-Cabot Electric Company constructed the outfit to Government specifications and under rigid Navy Department supervision.

The outfit consists of a low-impedance carbon microphone (transmitter), securely fastened to a metal breast-plate, and a set of heavy-duty, low-impedance earphones. A specially constructed switch on the back of the breast-plate controls the microphone circuit. The earphones are U.S.N. Utah type, attached to adjustable headband. Twenty-eight feet of very heavy weather and waterproof conductor cable, terminating in a special brass plug, is furnished with this complete outfit. Current of not more than 10 volts should be used. A storage battery is the most satisfactory current supply. Talk in a natural tone of voice, when using the outfit, with the lips close to the mouthpiece. Shouting and loud talking should be avoided.

We understand that the U.S. Government paid more than \$40.00 for each of these outfits. We have bought the whole lot at a low price and are offering them, as long as the supply lasts, at \$4.96 each, complete as shown in illustration. The shipping weight is 9 lbs.

All merchandise in original packages—never used. Money-back guarantee.

All Shipments will be forwarded by Express Collect if not sufficient postage included.

WELLWORTH TRADING CO.  
1915 So. State St., Dept. RC-141, Chicago, Ill.

RECORDING CHASSIS  
Efficient, Low priced. For experimenters, amateurs, P.A. and servicemen, etc. Small, rugged, compact, easily installed. Hooks up to any amplifier or set. Ultra efficient. Constant speed motor (not synchronous). 78 RPM. Req. 2 watts. Cuts out to in at 118 lines to 10 in. blanks. Net wet 12 1/4 or packed 18 lbs. for 60, 50 or 25 cps. (state which). If not available at your jobber or dealer, write direct.  
List \$39.50  
UNIVERSAL MICROPHONE CO. LTD., Inglewood, Calif., U. S. A.

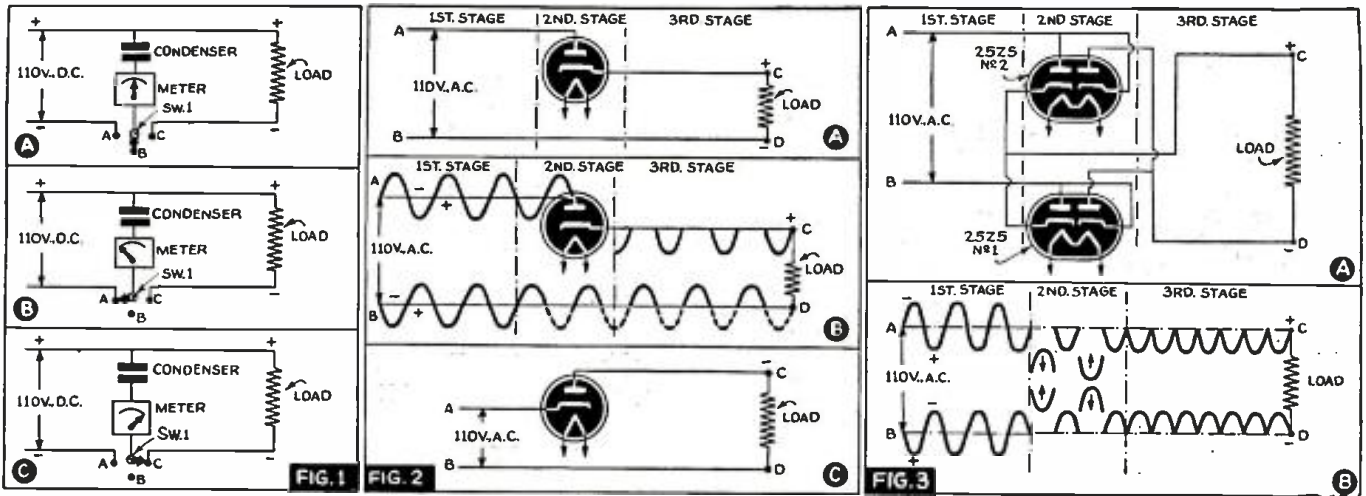

# VOLTAGE MULTIPLIERS

## And How They Work

In the following article the author analyses the various types of voltage multipliers (doublers, triplers, etc.) and presents working diagrams for high-voltage transformerless circuits from low-voltage sources. Voltage dividers also are mentioned.

STEVE KUSEN

In order to reduce this article to fundamental considerations the writer has divided it into the following sections:

- (1) How a Condenser Works;
- (2) Half-Wave and Full-Wave Rectifiers;
- (3) Use of a Condenser in a Half-Wave and Full-Wave Rectifier;
- (4) Voltage Doublers and Polarity Reversers;
- (5) Voltage Triplers, Quadruplers, Quintuplers, etc.

All the circuits and theories described in these articles are based on facts and experiments conducted in the laboratory.

We urge all experimenters and technicians to use caution in trying out the voltage multiplier circuits as very high voltages can be had. Don't let the simplicity of the circuits fool you.

### CONDENSERS

In order to understand Voltage Doubling, you first must familiarize yourself with simple half-wave and full-wave rectifiers, and condensers.

Condensers are the most important thing in Voltage Doubling for it is they which really affect the multiplication of the voltage. Some people think that tubes cause the doubling, but this is not so, the tube by performing the action of a valve, merely allows current to flow in one direction during certain periods of time.

When a D.C. voltage is impressed upon a condenser, the condenser will store up a current (charge) which depends upon the capacity of the condenser, and if the volt-

age, which was impressed upon the condenser, is removed, and the terminals of the condenser connected across a load, the condenser will discharge a current which is opposite in direction to the current which charged it; and, at a voltage equal to the one impressed upon it. For example, see Figs. 1A, B, and C.

Since we have to work with electrolytic condensers (polarized condensers) we must remember that the electrolytic condenser will act the same as an ordinary paper condenser only when the voltage impressed upon it is of the same polarity as the polarities indicated at the respective terminals of the condenser.

In Fig. 1, at A, when switch 1 is at B the meter needle will stay at zero because there is no complete circuit; at B, when switch 1 is at A the meter needle will move to the left and then slowly return to zero, showing that the condenser is charged; when switch 1, illustration C, is at C the needle will move to the right and slowly return to zero, showing that the condenser is discharged.

Note that the voltage discharged by the

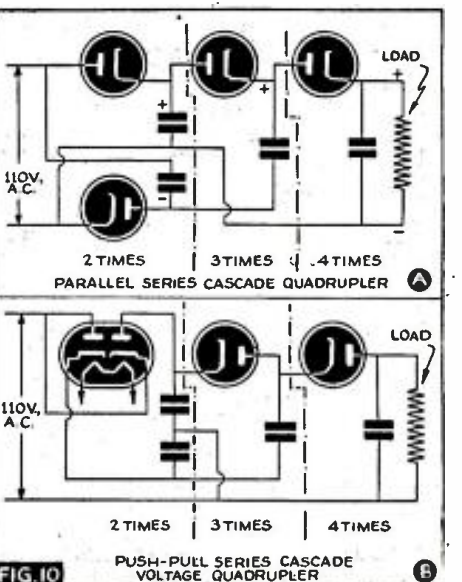
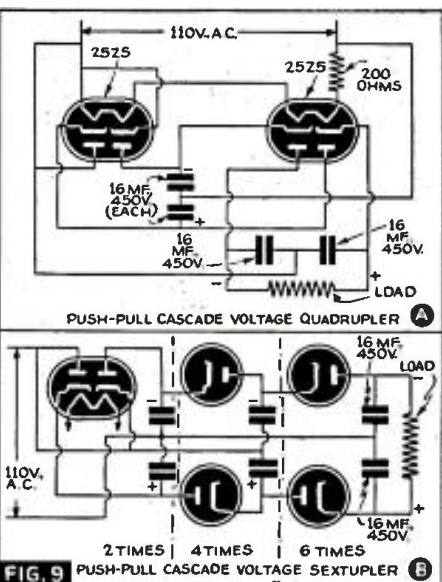
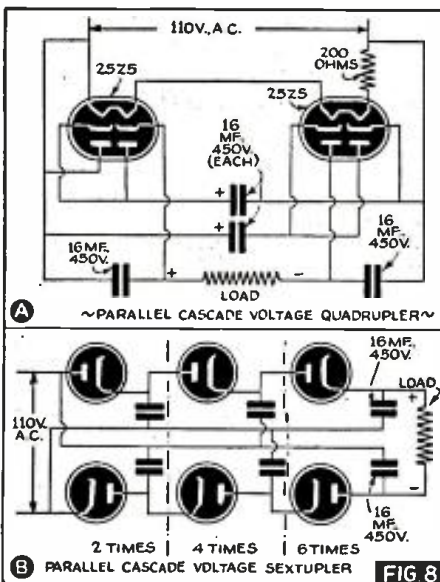



Buy your **HOWARD** Communication Receivers

from **BOB HENRY-W9ARA**  
 BUTLER, MISSOURI

During the last ten years I have sold more than 10,000 communication receivers. I have satisfied my customers and won thousands of customers everywhere. This enables me to know just what make of receivers the amateurs like.

The *HOWARD Progressive Series Plan* has proven to be the outstanding investment in communication receivers. Write to me for complete technical information on these receivers and I will gladly help you get the right receiver and will personally cooperate with you to see that you are 100% satisfied.

YOU get a ten day free trial. YOU don't buy unless you are satisfied. You get 6% terms financed by me with less cost. Less red tape. Quicker delivery. You get a big trade-in for your set—describe it and I will tell you its value.

You will get prompt shipments in factory sealed cartons from my complete stock of Communication Receivers. Or shipment from the factory if you prefer.

Your inquiries invited. I will send full information. Or send me your order and I will guarantee you can't buy for less or on better terms elsewhere.

**HOWARD MODEL "435"**

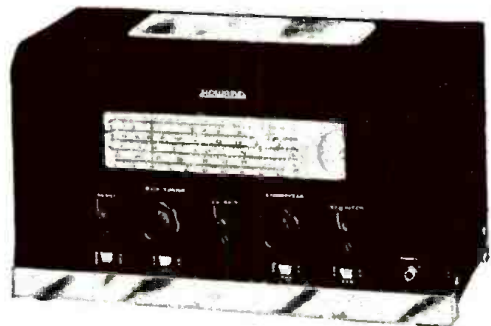

MODEL "435" IS THE BASIC MODEL  
 FOR *The Progressive Series Plan*

Model	Cash Price	Down Payment	12 Monthly Payments
435 complete .....	\$ 29.95	\$ 5.99	\$ 2.12
436 complete .....	39.95	7.95	2.83
437 less crystal .....	54.50	10.90	3.85
437 with crystal .....	62.00	12.40	4.38
490 complete .....	149.50	29.90	10.56

*Bob Henry*

**HENRY RADIO SHOP**  
**W9ARA • BUTLER, MISSOURI • W9ARA**

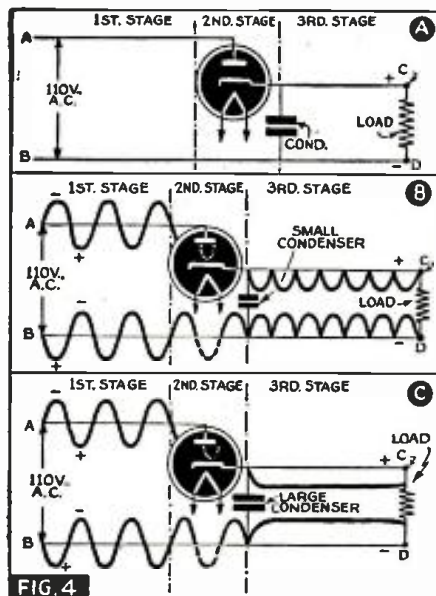

FIG. 4

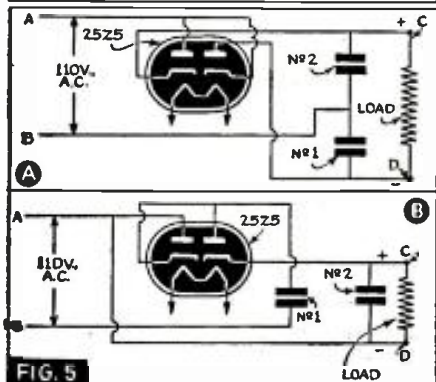

FIG. 5

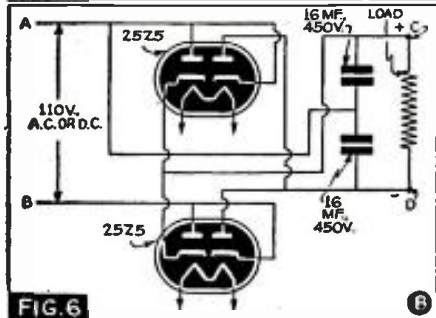

FIG. 6

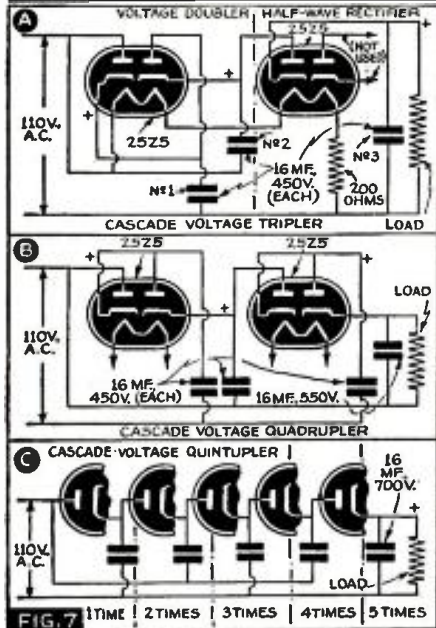

FIG. 7

condenser is always of the same polarity and magnitude as the voltage used to charge it. The current discharged by the condenser is always opposite in direction to the current that flowed through the condenser during the time the condenser was charging.

**HALF-WAVE RECTIFIERS**

A half-wave rectifier is anything which will permit an alternating current to flow in one direction, half the time during each cycle.

Since alternating current is really the same as direct current, except for its periodic reversals of its polarity, then all we have to do is extract half a cycle, either positive or negative, to get a direct current of pulsating nature. For example see Figs. 2A, B and C.

In Fig. 2, at A, when point A is positive and B is negative, a voltage is impressed across the load, thereby causing a current to flow through the load. When point A is negative and B is positive, no voltage is impressed across the load, so therefore no current will flow through the load; as shown at B, dotted lines indicate that there always remains an alternating voltage, at point D, but only a negative current. This is because when point D is positive, point C has no voltage, so therefore, there is no complete circuit and no current will flow. Illustration C shows a circuit which is the exact opposite of Fig. 2A because it makes use of the negative cycles. As you can see, point C, in Fig. 2C, is always negative as compared to point C in Fig. 2A where it is always positive.

**FULL-WAVE RECTIFIERS**

A full-wave rectifier is one which will permit an alternating current to flow in one direction all of the time during each cycle.

Since the current in a full-wave rectifier is flowing all the time as compared to a half-wave rectifier where it is flowing half the time, we therefore get a pulsating Direct Current twice as fast. See Figs. 3A and B.

In Fig. 3, at A, when point A is positive and B is negative, a voltage is impressed across the load, causing a current to flow from B through the cathode to the plate of No. 1 tube, through the load, through the cathode to the plate of No. 2 tube and back to A. When point A is negative and B is positive, a voltage is again impressed across the load, causing a current to flow from A, through the cathode to the plate of No. 2 tube, through the load, through the cathode to the plate of No. 1 tube, and back to B. As you can see the current is always flowing through the load in one direction, from D to C, because the voltage impressed across the load is always of the same polarity. In Fig. 3, at B, we see that the voltage across the load is continuous and contains no alternating component as did the half-wave rectifier.

There are several other forms of full-wave rectifiers but since a transformer or a center-tapped choke is necessary for their operation, we shall not discuss them. The full-wave rectifier described here is commonly called a bridge rectifier. Although there are various forms of bridge rectifiers, the one described here was invented by the author.

**THE CONDENSER IN A HALF-WAVE RECTIFIER**

Now we come to see what part a condenser plays in rectifier circuits. In Fig. 2, at A, we add a condenser to the circuit and we get the following results:

During the time current is flowing in the load, the condenser is charging and

during the time there is no current flowing, the condenser discharges, thereby filling in the empty spaces and giving us full-wave rectification; we therefore see that by adding a condenser that will collect a charge equal to the one drawn by the load, we can get full-wave rectification and by adding a bigger one we can get pure D.C. See Figs. 4A, B and C.

In Fig. 4, at A, when point A is positive and B is negative, a voltage is impressed across the load and the condenser, causing a current to flow through the load and at the same time charge the condenser. When point A is negative, and B is positive, no voltage is impressed across the condenser and the load therefore, the condenser which was charged starts to discharge, thereby impressing a voltage across the load, causing current to flow through the load. Note that a condenser discharges a voltage of the same amplitude and polarity as the one that charged it, therefore the voltage across the load is always of the same polarity and current will always flow in one direction from minus to plus.

As shown in Fig. 4, at B, the A.C. component tends to disappear. This is because the condenser tends to oppose or buck the opposing voltage. This gives a good reason why all chokes should be connected in series with the unrectified side of the line. Illustration C shows us that if we add a condenser large enough, it will store an excess current and discharge even when there is a small amount of current flowing, thereby making it higher and thus it tends to keep the current at a constant value.

**THE CONDENSER IN THE FULL-WAVE RECTIFIER**

In the full-wave rectifier since we have full-wave rectification we, therefore, don't need a condenser as large as in the half-wave rectifier to get pure D.C. The same goes for the A.C.-D.C. rectifier described in Fig. 3A.

Since the current in a full-wave rectifier is flowing all of the time, but is only varying in intensity, then all the condenser need do is keep the current at a constant value. It, therefore, acts as a storage tank, giving the current a boost when it is low.

**VOLTAGE DOUBLERS**

A voltage doubler is anything which will permit an A.C. (alternating current) to flow in one direction at twice the voltage obtained at the input. All voltage doublers are full-wave rectifiers because they employ condensers. These condensers act as storage tanks assuring a steady supply of current.

In Fig. 5, at A, we see a Push-Pull Voltage Doubler. When point A is positive and B is negative a voltage is impressed across condenser No. 2, thereby causing a current to flow from B to one side of condenser No. 2, charging it, and back through the cathode to the plate to line A. When point A is negative and B is positive, a voltage is impressed across condenser No. 1, causing a current to flow from A, through the cathode to the plate, to one side of condenser No. 1, charging it, and back to line B; at the same time this same voltage is in series with No. 2, which is discharging, the load which is across the combination, therefore, receives a voltage equal to the combined voltages. On the next part of the cycle, the reverse occurs; condenser No. 2 gets charged and condenser No. 1 discharges thereby giving us full-wave rectification plus voltage doubling. In Fig. 5, at B, we see a cascade voltage doubler; when point A is positive and B is negative, a voltage is impressed across condenser No. 1, therefore, causing current to flow from B,



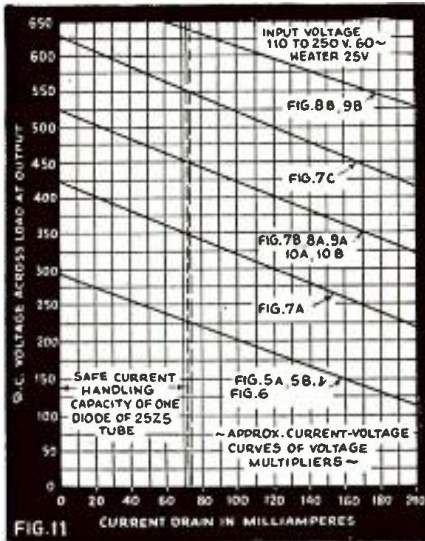

to one side of condenser No. 1, charging it, through the cathode to the plate of the tube and back to A.

When point A is negative and B is positive, no voltage is impressed across condenser No. 1, therefore it discharges. This discharge is in series (with condenser No. 2 and the line voltage); the voltage discharged by condenser No. 1 and the line voltage combine and impress a voltage across condenser No. 2 (causing it to charge) and the load (causing a current to flow through the load). Since a condenser will discharge a voltage equal to the one that charged it, therefore during the time there is no voltage across condenser No. 2 and the load, it will discharge giving us full-wave voltage doubling. Note that a D.C. voltmeter will not register a pulsating D.C. voltage unless it is continuous; omitting condenser No. 2 halves the reading.

**POLARITY REVERSERS**

A polarity reverser is anything which will automatically reverse the polarity at the input to give a fixed polarity at the output; for example, in all D.C. and A.C.-D.C. sets on the market, we find that in order to make the set operate on D.C. we must insert the plug at a correct polarity, and many of you may recall having to reverse the plug in order to get the set to operate.

In Fig. 6 we see a full-wave rectifier that was described in Fig. 3. This is really a polarity reverser, and will give a fixed polarity at the output regardless of the polarity of the input. (\*) All full-wave rectifiers are not polarity reversers, only the bridge rectifier is.

In Fig. 6, we also see that by adding 2 condensers to the circuit, we can take advantage of having a voltage doubler at A.C. and a polarity reverser at D.C. This circuit operates similarly to the voltage doubler described in the preceding topic. This circuit was invented by the author.

**VOLTAGE MULTIPLIERS**

Anything that will permit an alternating current to flow in one direction at a higher voltage at the output than was applied at the input can be put in the class as a voltage multiplier. All voltage multipliers employ condensers and therefore, they give a full-wave output.

In Fig. 7, at A, we see a Cascade Voltage Tripler (a circuit which combines a voltage doubler and a half-wave rectifier, connected in cascade so as to form a voltage tripler).

During the time condenser No. 2 of the voltage doubler is discharging, it impresses a voltage in series with the line voltage

\*See "Building a 1-Tube Portable Universal-Current Set," Radio-Craft, Jan. 1933.

which combined are impressed across the load (causing current to flow through the load) and condenser No. 3 (causing it to charge). During the time no voltage exists across condenser No. 3, it will discharge and impress a voltage across the load causing current to flow through the load. As can be seen, current is flowing through the load constantly, at voltage 3 times the line voltage.

If we trace the circuit, in Fig. 7, at B and C, we can easily see that by adding a condenser and a half-wave rectifier in series with the preceding condenser, rectifier, and line, we can get a voltage 4 times as high as the line voltage; to obtain voltages as high as desired, merely add condensers and rectifiers.

Since the cathode and plates of each tube are connected in series we can see that peak inverse voltage between cathode and plate need not bother us, but there exists a high voltage between cathode and heater which might prove troublesome at voltages higher than 600. It must be remembered that the working voltage of each successive condenser must be higher than the preceding ones. This goes also for the circuits to be described in the following topics.

**VOLTAGE MULTIPLIERS (CASCADE CONNECTION)**

In Fig. 8 we see a Parallel Cascade Voltage Multiplier (a different form of voltage multiplier).

In this circuit each pair of condensers is charged at a time, and therefore when they discharge, the next pair of condensers is charged simultaneously by a voltage equal to the discharge voltage of the previous condenser plus the line voltage. We therefore get a voltage on the output equal to the peak voltage discharged by the 2 condensers in the output or 4 times as much.

**VOLTAGE MULTIPLIERS (PUSH-PULL CASCADE CONNECTIONS)**

In Fig. 9 we see a Push-Pull Cascade Voltage Multiplier.

This is merely 2 or more voltage doublers so connected that each successive condenser receives a charge equal to the voltage discharged by the previous condenser plus the line voltage. From the voltage multiplier circuits described in this article, the writer obtained voltages up to 700 with this circuit. For higher voltages, add more condensers and rectifiers.

In Fig. 10 we see 2 different forms of voltage multipliers: a "Parallel Series" and a "Push-Pull Series" Cascade Voltage Multiplier.

All circuits described in this article (except voltage doublers and half-wave rectifiers) were invented by the writer, and are given to the U. S. Government and its people, and he urges all firms and individuals not to try to patent them.

After communicating with RCA Mfg. Co. about the maximum voltage between heater and cathode, the writer was informed that it is possible to impress high voltages between cathode and heater and still be able to operate the tube efficiently, but the RCA tube is not guaranteed for voltages higher than 300 volts between cathode and heater. The writer has had voltages as high as 700 volts between the cathode and heater without any apparent harmful effects on the tube.

The writer would like to inform Radio-Craft readers that all voltage multiplier circuits described here are also automatic voltage dividers. For example should any one build the circuit illustrated in Fig. 7C not only would he be able to get 700 volts but he would also be able to get 600, 500, 400, 300, 150 volts by connecting a circuit between the plate of each previous diode in any side of the line.

GET THE ALLIED BOOK OF RADIO VALUES NOW!



IT'S NOT JUST THE BIGGEST RADIO CATALOG IT'S THE BEST!

212 PAGES Bargain Section 15,000 ITEMS FREE



83 NEW SETS



P.A. 7 TO 75 WATTS



NEW TESTERS



LATEST HAM GEAR



BUILDERS SUPPLIES

You'll want to see the KNIGHT 1941 "Radio Hits!" 83 new models to choose from—new "camera" and 3-way Portables; Plastic models; World-wide sets; Farm Radios. Also new Recorders, Phono-Combinations, Phonograph Players and accessories. Auto Sets, etc. No finer radio set values anywhere! Just compare these KNIGHT "Leaders!"

You get more for your P.A. dollar when you buy 1941 KNIGHT Sound Equipment. Never before so wide a selection; never so many fine features. 24 new Systems—7 to 75 watts—for every kind of P.A. application. Complete accessories listing. Get the details of our Easy Payment Plan and 15 Day Trial!

You've never seen a bigger or better Service Section! Over 100 value-packed pages of new Test Equipment, tools—more than 15,000 quality parts for servicing every make of set. Radio's best Parts Guide—Radio's Lowest Prices! Also new and bigger Bargain Section—don't miss it! See the big Fluorescent Lighting Listings!

Amateurs—you'll find the most complete Amateur listings you've ever seen in this 1941 ALLIED Catalog! See then all—the latest communications receivers, new transmitters, all the newest gear in every leading line. Really a catalog in itself—jam-packed with Amateur values that you can't afford to miss. Time Payments, too!

BUILDERS—Latest brand-new kits. Complete listings of the latest builders and experimenters supplies. New diagrams. New! Radio DICTIONARY—Compiled by leading authorities. Gives concise definitions of all commonly used radio words and terms, historical data, etc. Everyone in Radio should have it. Send coupon Today—only 10c.

See Our Fluorescent Listing

ALLIED RADIO

833 W. Jackson Blvd. Dept. 2-A-1 Chicago, Illinois

Send me your FREE 212 Page 1941 Catalog.  
 I enclose 10c for New Radio Dictionary.

NAME .....  
Address .....  
City ..... State .....

FREE



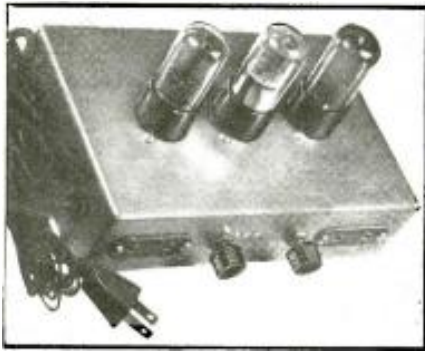

Front view of the complete Phono-Oscillator.

## Build This High-Gain

# 3-TUBE PHONO-OSCILLATOR

The author describes an easily-built "wireless" oscillator which incorporates the latest improvements in this type of phono-player. A microphone input, for example, makes it possible for the experimenter to use this instrument for mock broadcasts.

L. M. DEZETTEL, W9SFW

**A** DE LUXE TYPE of "wireless" oscillator, this Phono-Player includes many unusual features that add to its versatility. Two inputs are used, one having greater amplification than the other. One is used for connecting a phonograph pickup of the crystal or magnetic type; and the other, for a microphone of the dynamic or crystal type. Each input is independently controlled by its own volume control.

### USES

This is a great little unit for home entertainment, as phonograph records may be played alone or "mixed" with the microphone channel, so that a person may sing along with the playing of the record and "broadcast" into your home receiver.

With a little ingenuity many interesting stunts can be devised in which this unit may be utilized. For instance, you can arrange an "Amateur Hour." With the Phono-Player or "Oscillator," an electric phonograph unit, and a microphone set up in the kitchen, for example, you can put on a regular broadcast, using a few of the more talented folks in the party. With the rest of the crowd in the living room, tune-in your "station" on your living room radio just as you would any broadcast station.

This "Wireless" Oscillator may be placed as much as 50 ft. from your set and still be picked-up with good volume.

The latest single-ended hantam tubes are used. A 12SF5GT tube is used as the microphone amplifier; a 12SA7GT tube functions as a modulated oscillator; and a 35Z4GT tube is the rectifier. No transformers are used. It is possible to operate this unit from 105-125 volts, either D.C. or A.C., 50 to 60 cycles. The filaments of the tubes are connected in series and a resistor, built into the line cord, is used to drop the voltage to

the proper value for the tubes.

### ASSEMBLY

Assembly and wiring is straight-forward. Mount the parts on the chassis exactly as shown. Mount the oscillator coil last so that it will not be damaged during assembly. The filter condenser, line cord and antenna, should be left until you are nearly through so that they will not be in your way during the connecting of the smaller parts.

For unfailing results all connections should be soldered. Keep leads short by making connections direct from one point to another. Clip-off excess wire on the resistor and condenser terminals, using only as much of the pigtail leads as necessary. Notice that many of the unused socket terminals are used for making connections to other parts as a convenience in wiring. Check off each lead on the diagram as you wire the oscillator. In this way you reduce the possibility of overlooking connections.

### FINAL STEPS

When wiring is completed, uncoil the antenna wire, put the tubes into their proper sockets and plug the Oscillator into a 115 volt A.C. or D.C. outlet. Now turn on your radio receiver and set the tuning dial to a spot in the broadcast band where no stations can be heard. The volume control on your radio receiver should be set at normal volume. Now go back to your Oscillator and connect your record player or microphone into the proper input. While playing the record or speaking into the microphone adjust the trimmer condenser through the opening on the left until the music or voice is heard in the radio set. A small screw-driver is used for this adjustment. The volume control on the oscillator must be turned up, of course, during the tuning. Volume increases as the knob is tuned to the

right; and is off when the knob is at the extreme left.

When connecting the leads from the record player pickup, the outer shield should be connected to the left tip-jack on the phono-input, and the inner conductor to the right tip-jack. If the leads are not shielded, connect them whichever way produces the least amount of hum. This also applies to the connection of the microphone.

Any high-impedance, high-output microphone may be used in the microphone channel. The inexpensive dynamic microphones will work nicely. The new and crystal mikes may also be used.

You may experience some hum in using a microphone with this unit as the microphone input channel has considerable amplification. If long leads are used on the microphone, the leads should be of the shielded type. The shielded lead must be connected to the metal case of the microphone and at the other end is soldered into a phone tip and plugged into the left-hand jack of the microphone input. The inner conductor is the "hot" lead. This is also soldered to a phone tip and plugged into the right-hand jack of the microphone input. It has probably become apparent to you by this time that this little unit is, in effect, a small transmitting station. There are Federal regulations governing the transmission of signals over a considerable distance without a license. We must caution you not to use this unit with an outside antenna or attempt to transmit outside the environs of your own home.

### LIST OF PARTS

#### CONDENSERS

- One 5-section filter condenser;
- Two 0.1-mf. 200-volt;
- One 0.05-mf., 400-volt;
- One 0.02-mf., 200-volt;
- Two 100 mmf.;

#### RESISTORS

- One 700-ohm, ½-watt;
- One 9,000-ohm, ½-watt;
- Two 50,000-ohm, ½-watt;
- One 0.25-meg., ½-watt;
- Two 60,000-ohm, ½-watt;
- One 50-ohm, ½-watt;
- One 0.5-meg., ½-watt;
- One volume control with switch, 0.5-meg.;
- One 500,000 ohm volume control less switch, 0.5-meg.

#### TUBES

- One 12SF5GT tube;
- One 12SA7GT tube;
- One 35Z4GT tube.

#### MISCELLANEOUS

- One "Knight" special oscillator coil;
- Two input tip-jacks;
- One 6-point wiring strip;
- One "Knight" special punched and drilled chassis;
- One 400-ohm line cord and plug;
- One hank antenna wire, 25 ft.;
- Three octal sockets;
- Hardware.

This article has been prepared from data supplied by courtesy of Allied Radio Corp.

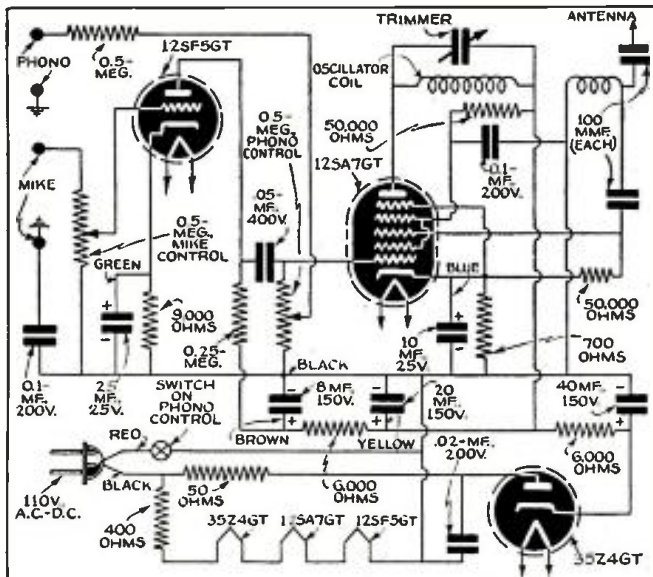

Schematic diagram of the High-Gain 3-Tube Phono-Oscillator. It incorporates many unusual features that add to its versatility. The input provides for (1) crystal or magnetic phono pickup; or, (2) a crystal or dynamic microphone. The inputs may be independently controlled; or, they may be mixed, as desired.



# For Better Servicing - For Bigger Profits— USE GERNSBACK MANUALS AND BOOKS!

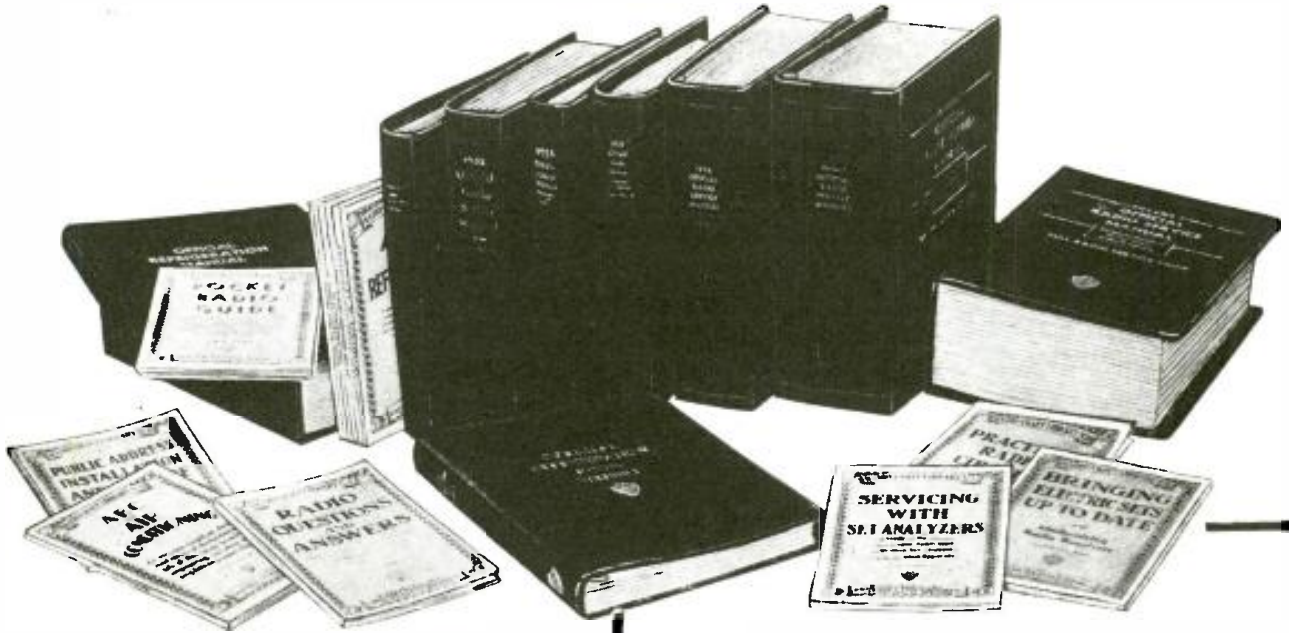

**S**INCE 1931 Servicemen have been buying more GERNSBACK OFFICIAL RADIO SERVICE MANUALS year after year. The authentic material, easily accessible diagrams and complete service data make them invaluable to dealers and radio Servicemen. *Without a Gernsback Service Manual at the repair job, there's time and profit lost.* Your service kit or laboratory is incomplete without all the GERNSBACK OFFICIAL RADIO SERVICE MANUALS. There are GERNSBACK MANUALS for servicing auto-radios, also refrigeration and air conditioning equipment.

### VOLUME 7 OFFICIAL RADIO SERVICE MANUAL

Over 1,800 Pages • Over 3,000 Illustrations • Stiff, Leatherette, Looseleaf Covers • Size 9 x 12 Inches • Net Weight 10½ lbs. **\$10.00**

### 1936 OFFICIAL RADIO SERVICE MANUAL

Over 1,200 Pages • Over 2,500 Illustrations • Stiff, Leatherette, Looseleaf Covers • Size 9 x 12 Inches • Net Weight 8 lbs. **\$7.00**

### 1935 OFFICIAL AUTO-RADIO SERVICE MANUAL

Over 240 Pages • Over 500 Illustrations • Flexible, Leatherette, Looseleaf Covers • Size 9 x 12 Inches • Net Weight 1¼ lbs. **\$2.50**

### 1934 OFFICIAL RADIO SERVICE MANUAL

Over 400 Pages • Over 2,000 Illustrations • Flexible, Leatherette, Looseleaf Covers • Size 9 x 12 Inches • Net Weight 2¼ lbs. **\$3.50**

### 1932 OFFICIAL RADIO SERVICE MANUAL

Over 1,000 Pages • Over 2,000 Illustrations • Flexible, Leatherette, Looseleaf Covers • Size 9 x 12 Inches • Net Weight 4½ lbs. **\$5.00**

### OFFICIAL REFRIGERATION SERVICE MANUAL

(Volume II)  
Over 352 Pages • Over 300 Illustrations • Flexible, Leatherette, Looseleaf Covers • Size 9 x 12 Inches • Net Weight 1½ lbs. **\$5.00**

### OFFICIAL AIR CONDITIONING SERVICE MANUAL

Over 352 Pages • Over 600 Illustrations • Flexible, Leatherette, Looseleaf Covers • Size 9 x 12 Inches • Net Weight 2¼ lbs. **\$5.00**

To order these famous Manuals, see or write to your jobber or favorite mail order house. If more convenient, mail coupon directly to publishers.

**RADCRAFT PUBLICATIONS, Inc.**  
20 VESEY STREET NEW YORK, N. Y.

## RADIO-CRAFT LIBRARY SERIES

Get into the swing of reading instructive, authoritative books on technical subjects—radio, air conditioning and refrigeration. It's the easiest, quickest and most inexpensive way to improve your knowledge on these topics. In this series, popularly known as the RADIO-CRAFT LIBRARY SERIES, are all the titles necessary to your personal advancement. Only by careful study of these enlightening books, can you gain adequate experience in fields of radio, air conditioning and refrigeration. Each book is uniform. The volumes measure 6 x 9 inches—contain 64 pages, and have stiff, flexible covers. PRICE 50c PER BOOK. All books are sent to you postpaid.

### Here Are The Titles:

Book No. 3  
THE SUPERHETERODYNE BOOK

Book No. 6  
BRINGING ELECTRIC SETS  
UP-TO-DATE

Book No. 9  
AUTOMOBILE RADIO AND  
SERVICING

Book No. 10  
HOME RECORDING AND ALL  
ABOUT IT

Book No. 13  
ABC OF AIR CONDITIONING

Book No. 14  
POCKET RADIO GUIDE

Book No. 15  
ABC OF REFRIGERATION

Book No. 16  
PRACTICAL RADIO CIRCUITS

Book No. 17  
SERVICING WITH SET ANALYZERS

Book No. 18  
POINT-TO-POINT RESISTANCE  
ANALYSIS

Book No. 19  
PRACTICAL RADIO KINKS  
AND SHORT CUTS

Book No. 20  
THE CATHODE-RAY OSCILLOSCOPE

Book No. 21  
BREAKING INTO RADIO SERVICING

Book No. 22  
NEW RADIO QUESTIONS  
AND ANSWERS

Book No. 23  
PRACTICAL PUBLIC ADDRESS

NEW—Book No. 24  
AUTOMOBILE RADIO  
PRINCIPLES AND PRACTICE

**EACH BOOK IN THIS SERIES—50c**

RADCRAFT PUBLICATIONS, Inc., 20 VESEY ST., NEW YORK, N. Y.

Gentlemen: Enclosed find my remittance of \$..... for which send me, POSTPAID, the Manuals or Books indicated below by a cross (x) in the panel.

( ) Volume 7 @ \$10.00 ( ) 1936 Manual @ \$7.00 ( ) 1934 Manual @ \$3.50  
( ) 1935 Auto-Manual @ \$2.50 ( ) 1932 Manual @ \$5.00  
( ) Refrigeration Manual (Vol. 2) @ \$5.00 ( ) Air Conditioning Manual @ \$5.00

RADIO-CRAFT LIBRARY SERIES @ 50c EACH

Circle book numbers wanted: 3 6 9 10 13 14 15 16 17 18 19 20 21 22 23 24

Name .....

City ..... State .....

(Send remittance in form of check or money order; register your letter if you send cash or unused U. S. Postage Stamps.)

RC-141

# RADIO RECORDS

## "7-MILE" 'CHUTE JUMP

*Anticipating increased activity in stratosphere flying, university scientists have instituted laboratory experiments in scientific "parachute jumping" from these unprecedented heights. Some of the problems involved are here described.*

**S**CIENTISTS of the University of Chicago and Northwestern University gathered last month in the laboratories of the Armour Research Foundation of Illinois Institute of Technology to conduct final tests preliminary to the planned 6½-mile scientific parachute jump by amateur Arthur H. Starnes. (See photo at right, and on *Radio-Craft's* cover.)

Aviation experts say that stratosphere flying has freed the industry from many hazards. And with the development of stratosphere flying, problems of jumping from altitudes of 35,000 feet must necessarily be solved. United States Army and Navy officials are interested in the researches, because of the increased importance of *parachute troops*.

First, it is necessary to determine whether it is possible for the human body to withstand the shock of falling from such heights; and second, whether the senses of the 'chutist will be able to respond to the delayed jump and thus be able to carry through the command of the brain for the pulling of the rip-cord when close to the ground. (It is necessary, in the case of stratosphere jumping, to delay pulling the rip-cord until fairly close to the ground so as to avoid frostbite or actual death from freezing because of the extremely low temperatures encountered at such high altitudes.)

When Starnes, fully equipped, stepped into the Foundation's 0°F. cold room; he was wearing strapped to his chest a pneumograph; in the pocket of his jumping suit was a "bail-out" oxygen tank; and, under the wind-proof mask strapped to his face

Arthur H. Starnes has strapped to his left hip, all the voice and heart-beat communications equipment he is testing "7 miles high" in the lab. wind-tunnel. Negotiations are under way to obtain an airplane capable of reaching this altitude.



was a molded oxygen breather. To his back was strapped the main 'chute he expects to rip open at 3,000 feet after a fall of 6 miles from the stratosphere.

Strapped to his side was the shortwave radio transmitter to transmit his heart action to observers; and across his throat was strapped a laryngaphone (throat microphone) to enable him to send by radio his personal reactions. On his wrist was an altimeter which would tell him when to pull the rip-cord, and strapped to his hip was a movie camera to record his gyrations. On his chest was the auxiliary 'chute for added protection which he pulls at about 700 feet to further break his fall. (After his 'chutes open, Starnes' rate of descent will be about 12 feet-per-second; until that moment, he will be hurtling downward at about 200 miles-per-hour.)

After a few minutes he stepped into a specially-designed -67° F. super-cold chamber and glass-enclosed wind tunnel con-

structed within the cold room.

Here, 2 high-powered blowers, drawing air at zero temperature through a revolving chamber soaked with liquid air, blasted a stream of air at 67° below zero and at 200 miles-per-hour directly into the 'chutist's face.

All of his conscious reactions, as he twisted and turned and exposed all parts of his body and all the equipment to the blast, and those subconscious reactions of which he could not be aware, were transmitted by shortwave radio to other parts of the Foundation laboratories. His heart beat was accurately recorded, as well as his breathing. His verbal reactions were recorded while the critical eyes of the scientists closely watched for any flaws in the design of the equipment he was wearing.

After being exposed to the excruciatingly low temperature, Starnes was removed from the tunnel and examined and questioned by the scientists.



At the turn of a switch, this gadget simulates a telephone dial tone, busy signal, 20-cycle ringing, etc. You may have heard this device operating in the new air program, "The Shadow", over the WOR Mutual network.

## 'PHONE SOUND-EFFECTS MACHINE

*The following article by station WOR's Sound Effects Supervisor, describes a new sound-effects instrument that reproduces the major sounds heard over a telephone line and makes them available for instant mixing into radio broadcast programs. Eventually, this instrument will be vacuum-sealed!*

F. G. STREET, JR.

**T**OO often for comfort a sound effects man gets a request for the sound of a telephone instrument being hung up at the other end of the line, or a busy signal, or the sound of ringing as heard in the receiver.

Various combinations of buzzers and equalized microphones have been used to simulate these sounds, but without any feeling that the imitations were particularly good.

The WOR Sounds Effects Department decided to see what could be done toward developing a device that would accurately reproduce the more important sounds heard over a telephone line.

The New York Telephone Co. was kind enough to furnish a drawing showing the connections of a buzzer to furnish the dial tone and a system of 2 time-delay relays to interrupt this tone in such a way as to produce the busy signal.

*The Dial Tone; Busy Signal.*—Everything seemed solved. It was only a matter of connecting these up, plugging them into a mike circuit, and the work was done. But before this was started it was realized that the sound operator would have to dial on a dead phone, press the dial tone key, release it in exact synchronism with his dialing, and do this accurately every time. It was then decided to control the dial tone



with additional relays, and these were added, so that the dial tone came in as soon as the instrument was lifted, and was cut off and stayed off as soon as the dial was turned the first time. This, however, did not give that final buzz that is heard as the dial returns the first time, and 3 more relays were added to secure this short peep before the final cut-off.

**Ring Impulse.**—The ringing impulse as heard at the other end seemed simple enough to duplicate, as we already had a 20-cycle generator used for ringing phone bells. This was fed, through a transformer and resistance, into the circuit, but it did not sound right. It was found that this sound is not composed of the 20-cycle ringing current alone, but of a higher note (about 800 cycles) modulated by the 20-cycle impulse. In order to secure this complex sound several means were tried, but the one that finally duplicated it almost exactly consisted of a single tube oscillator, with plenty of harmonics, the output of which was fed to the control-grid of a second tube, while the 20 cycles fed to the cathode served to modulate it.

**Local Cradling.**—Another trouble that developed was that if the cradle contacts were opened for even a moment, as in attempting to call back the operator, the dial tone returned. In order to avoid this a holding relay was inserted, which was operated by the plate current of a 6A3. When the phone is hung up, or the contacts pressed, the filament current of the 6A3 is cut, but until the filament has cooled a bit, plate current continues to flow, the relays cannot unlock, and the dial tone cannot return. *By trying several tubes it was possible to get one with characteristics such that the phone must be hung up about 2½ seconds before dial tone will be heard on lifting it again.*

**Remote Cradling.**—The hanging up or lifting of the phone at the other end of the line was another sound that seemed simple until we tried it. The first idea was to have another instrument connected in the circuit, to be used at some distance from the machine. The actor who was supposed to be talking over the line would use this instrument just as he would any telephone. Then it was realized that an actor following a script would have some difficulty locating the cradle and hanging up exactly on-cue. So a second instrument was placed in series with the one the actor was to talk through, and the hanging up of this one was controlled by the sound operator right at the machine through a mechanical device. Two relays controlled by this instrument cut the voice lines from both, so that when it is hung up, the clatter is heard, and then

everything is cut, even though the actor may continue talking. In order to make sure that all sounds from this instrument went out only over the line, it was mounted in a heavily-padded box, so that no mechanical noise would be picked up by studio microphones.

**Level Controls.**—Attenuators control the level of the dial tone, the ringing impulse, and the final mixed output of the machine, which is fed through a mike line directly into the control room, and also, through a single-stage amplifier, into the receiver of the instrument on the near phone, which the operator can use for monitoring purposes.

**Acoustic Filter.**—To secure the closest approximation to telephone quality, an acoustic filter is used, which consists of a receiver, also fed by the monitor amplifier, held against a dynamic microphone in such a way as to duplicate approximately the resonance of the ear cavity. Either the output of this microphone or the unfiltered output of the final mixing coil can be fed into the control room by throwing a key.

**Visual Monitors.**—Pilot lights were introduced on the control board so that the operator can monitor all operations even though he does not have a hand free to hold the monitor phone instrument.

**Equipment.**—The machine as finally completed contains 8 monitor lights, 8 keys controlling ringing impulse, busy signal, incoming or outgoing calls (to avoid getting dial tone on an incoming call), dial clicks, operator's buzzer, filter, and auxiliary bells; a knob for lifting the remote cradle, 4 attenuators, a high-pass filter, 3 separate power supplies. (18-volt, 3-volt, and 1-volt batteries), oscillator, modulator, amplifier, voltage regulator, 20-cycle generator, time-delay tube, 9 mixing coils, 18 interlocking relays, and 3 telephone instruments.

One difficulty still in the process of solution is caused by the fact that the acoustic filter, since it contains a sensitive microphone and must be incorporated within the cabinet, is very receptive to noises other than those intended for it, such as the thumping of the busy-signal relays, and even voices from outside the cabinet.

*It is planned to seal the whole unit in an air-tight copper tube which will in turn be sealed into a heavy copper box which will then be exhausted with a mercury diffusion pump to a vacuum of about 10<sup>-4</sup> millimeters of mercury. This should eliminate pick-up of any sounds except those from the receiver and the imperceptible ones which will be acoustically transmitted through the leads by which the unit is suspended.*

COMBINATION RADIO AND INTERPHONE

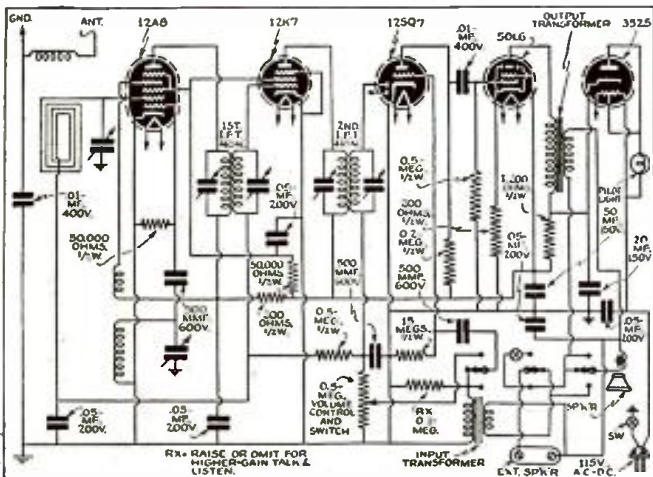

Here is the diagram of the combined Radio Receiver and Interphone illustrated by photograph on page 393 (Radio Month in Review Department).

SAVE MONEY WITH THIS Free Book



What a book to have! Just open it to the section you are interested in—there's your radio, sound system, your choice of nationally advertised parts. Everything in radio is here. But that's only the start of the story! Lafayette prices are the lowest—saving you money on everything you buy. Send for your FREE copy of this great buying guide today. Just tear out and mail the coupon.

Lafayette Radio  
100 SIXTH AVENUE, NEW YORK, N. Y.  
CHICAGO • ATLANTA • BOSTON  
NEWARK • BRONX, N. Y. • JAMAICA, L. I.

LAYAYETTE RADIO CORP.  
DEPT. 3A1 — 100 SIXTH AVE., NEW YORK, N. Y.  
Rush FREE Catalog No. 82

NAME \_\_\_\_\_  
ADDRESS \_\_\_\_\_  
CITY \_\_\_\_\_ STATE \_\_\_\_\_



ELEMENTARY MATHEMATICS

EASY — SIMPLIFIED — PRACTICAL

HERE is a book for the business man, the technician and craftsman explaining and answering every operation and meaning with interpreting illustrations and examples. It is the key to a simple understanding of many perplexing problems in daily life. In clear, positive and definite language, the author popularizes and clarifies every subject and helps the reader to overcome any apparent difficulty in the study of mathematics. A real home study-course in mathematics for the student or the man who wants to achieve proficiency or desires to brush-up on his knowledge.

Entire Chapter on Special Mathematics for the Radio Technician

CONTENTS OF BOOK  
CHAPTER I. Arithmetic—Addition—Subtraction—Multiplication—Division  
CHAPTER II. Factoring and Cancellation—Fractions—Decimal—Percentage—Ratio—and Proportion.  
CHAPTER III. The Metric System.  
CHAPTER IV. How to Measure Surfaces and Capacity (Geometry).  
CHAPTER V. Powers and Involution—Roots and Evolution.  
CHAPTER VI. Mathematics for the Manual and Technical Craftsman—Thermometer conversions—Graphs or Curve Plotting—Logarithms—Use of the Slide Rule.  
CHAPTER VII. Special Mathematics for the Radio Technician.  
CHAPTER VIII. Commercial Calculations—Interests—Discounts—Short Cut Arithmetic.  
CHAPTER IX. Weights and Measures—Useful Tables.  
"Elementary Mathematics" can be carried readily in your pocket. Send Stamps, Cash or Money Order.

ONLY 50c POSTPAID

TECHNIFAX

1917 S. State St. RC-141 Chicago, Ill.

GOLDENTONE... 50% OFF

DEAL DIRECT FACTORY PRICES — Over 80 models to choose from — 1 1/2 tubes. Portables \$8.00 up. Farm sets \$8.95 up. Car sets \$8.95 up. Foreign band sets \$8.08 up. Samples 50% off. Quantity discounts. Free 1941 Bargain catalog gives details of 10-day FREE trial, agent's proposition and discounts. Mail postcard. GOLDENTONE RADIO CO., DEPT. RC, DEARBORN, MICH.

10 DAY TRIAL 49% OFF

Free Catalog RCA



# 10 BEST RADIO BOOKS 10¢ ea.

RADIO FANS EVERYWHERE—these fine ten cent text books give you an excellent foundation for the study of RADIO. They are clearly written, profusely illustrated and contain over 15,000 words in each book. You'll be

amazed at the wealth of information contained in these handy books. Excellent for reference—ideal for every technical library. YOUR MONEY BACK if you are not satisfied. PROMPT SHIPMENTS

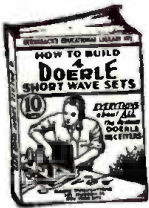

**No. 1**  
**HOW TO BUILD DOERLE SHORT WAVE SETS**  
Thousands of radio fans have built the famous DOERLE Short Wave Radio Receivers. So important has been the demand for these receivers, as well as construction details, that this book has been specially published. Contains EVERYTHING that has ever been printed on these famous receivers.

**No. 2**  
**HOW TO MAKE THE MOST POPULAR ALL-WAVE 1- and 2-TUBE RECEIVERS**  
This book contains a number of excellent sets, some of which have appeared in past issues of RADIO-CRAFT. These sets have been carefully engineered. They are not experiments. Not only are these sets described in this book, but it contains all of the illustrations, hookups, etc.

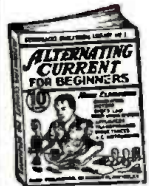

**No. 3**  
**ALTERNATING CURRENT FOR BEGINNERS**  
This book gives the beginner a foothold in electricity and Radio. Electric circuits are explained. Ohm's Law, the demand for the fundamental laws of radio, is explained; the generation of alternating current sine waves; the units—volts, amperes, and watts are explained. Condensers, transformers, A.C. instruments, motors and generators.

**No. 4**  
**ALL ABOUT AERIALS**  
This book explains the theory underlying the various types of aerials; the inverted "L," the Doublet, the Double Doublet, etc. It explains noise-free reception, how low impedance transmission lines work; why transposed lead-ins are used. It gives in detail the construction of aerials suitable for long-wave broadcast receivers, for short-wave receivers and for all-wave receivers.

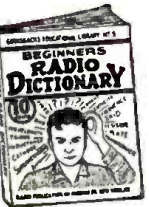
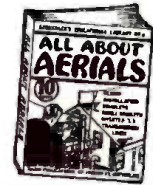

**No. 5**  
**BEGINNERS' RADIO DICTIONARY**  
Are you puzzled by radio language? Can you define Frequency? Kilocycle? Triode? Screen grid? Baffle? Anode? Triode? Pentode? Ionization? Foule's Law? Harmonic? Gravity Cell? If you cannot define these very common radio words and dozens of other, more technical, terms used in all radio magazines and instruction books, you need this book in your library.

**No. 6**  
**HOW TO HAVE FUN WITH RADIO**  
Stunts for Parties. Practical Jokes, scientific experiments and other amusements which can be done with your radio set are explained in this fascinating volume. It tells how to make a newspaper talk—how to produce silent music for dances—how to make visible music—how to make a "silent radio" unit, usable by the deafened—how to make toys which dance to radio music, etc., etc.

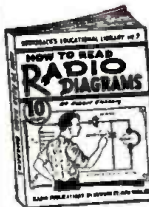

**No. 7**  
**HOW TO READ RADIO DIAGRAMS**  
All of the symbols commonly used in radio diagrams are presented in this book, together with pictures of the apparatus they represent and explanations giving an easy method to memorize them. This book by Robert Elchenberg, the well-known radio writer and member of the editorial staff of RADIO-CRAFT Magazine, also contains two dozen picture-wiring diagrams of simple radio sets that you can build.

**No. 8**  
**RADIO FOR BEGINNERS**  
Hugo Gernsback, the internationally famous radio pioneer, author and editor, whose famous magazines, RADIO AND TELEVISION and RADIO-CRAFT are read by millions, scores another triumph with this new book. Any beginner who reads it will get a thorough ground work in radio theory, clearly explained in simple language, and through the use of many illustrations. Analogies are used to make the mysteries of radio clear.



**No. 9**  
**SIMPLE ELECTRICAL EXPERIMENTS**  
Over 100 interesting and practical electrical experiments are described in this book, covering every branch of electricity—from simple experiments with magnets to high frequency "stunts." All of the experiments described can be carried out with simple apparatus, most of which can be found about the home.

**No. 10**  
**TELEVISION**  
Every one is asking the question: How does television work? This book explains all of the different systems of television from the simplest to the most complex. It describes in A-B-C style just how the image is scanned, how the scene is picked up by the television camera and broadcast to your home, etc. Various types of television systems are described.



### BOOKS ARE ALL UNIFORM

Every book in the GERNSBACK EDUCATIONAL LIBRARY has 32 pages—with illustrations varying from 30 to 66 in number. Each title volume contains over 15,000 words. Positively radio's greatest book buy! If you do not think these books worth the price asked, return them in 24 hours and your money will be instantly refunded.

## RADIO PUBLICATIONS • 20 VESEY STREET • NEW YORK, N. Y.

RADIO PUBLICATIONS, Dept. RC-1-41,  
20 VESEY STREET, NEW YORK, N. Y.  
Gentlemen: Please send immediately, POSTPAID, the book numbers circled below. I am enclosing ..... cents—each book being 10c.

1 2 3 4 5 6 7 8 9 10  
NEW NEW

Send FREE listing of 48 new 10c publications.

Name ..... Address .....

City ..... State .....

Remit by check or money order—register letter if you send cash or unused U. S. postage stamps.

**MAIL COUPON TODAY!**

## ABOUT CALL LETTERS

Some call letters used today have been inherited from stations which made headlines through tragedy. *KGB*, now assigned to a station at San Diego, was formerly used by the steamship *D. H. Luckenbach*, sunk by a submarine off the coast of France in 1917. *KOB*, at Albuquerque, New Mexico, was assigned to the steamship *Princess* until she broke in two on Rockaway Shoals, New York. Radio played an important role in the rescue of the 106 persons on board.

Using 4 letters, there are nearly 50,000 possible call-letter combinations. This is not sufficient to take care of amateur radio stations, which greatly exceed all others in number, so a special system of call assignments had to be worked out for the self-styled "hams."(\*)

Result: about 100,000 letter permutations have been used in amateur calls. Hundreds are assigned weekly in new, renewed, or modified licenses. The plan adopted for amateurs is governed partly by treaty, partly by statute, and partly by regulation.

Treaty limits an amateur call to not more than 2 letters plus 1 digit plus not more than 3 letters, and assigns initial letters to indicate nationality. Statute authorizes the Federal Communications Commission to designate and publish calls. Regulations give preference to assignment in regular order rather than on a request basis.

Thus an amateur call comprises a prefix, a digit, and a suffix. For example, *W1AAA*. The prefix, indicating nationality, must be or begin with one of the 3 letters assigned to the United States—*W*, *K* or *N*. For amateurs located in continental United States, *W* is used by itself. Thus *W1AAA* would be in New England. For outlying areas, *K* is used as the prefix. Example: *K7AAF* would be in Alaska.

The *K* prefix is expanded to 2 letters for remote spots to give distinctive character, immediately recognizable on the air without reference to lists. Example: *KB6GXB*, in Guam. *N* is not used as a prefix in assigning amateur calls, but may be temporarily substituted for any of the other prefixes by Naval reservists under certain conditions.

The digit in amateur calls indicates location in one of the 9 amateur call areas now in operation.

The suffix in new assignments is chosen in regular order from the permutations of the alphabet. For example, the calls *W3ILE* and *W3ILF* were the other day assigned to new amateur stations in the 3rd call area. The same practice holds true for each call area. Thus a suffix early in the alphabet has been used in all 9 areas and may be common to the calls of 9 stations, e.g. *W1ABC*, *W2ABC*, *W3ABC*, etc. However, the same suffix is not simultaneously used after *W6* and *K6*. If an amateur moves from Hawaii to California, say, only the prefix is changed in his modified license, as *K6MTH* to *W6MTH*.

In general, an amateur is assigned and reassigned the same call as often as consistent with his location and the adopted system. Accordingly, so-called 2-letter calls (2-letter suffixes) are renewed or revived for former holders, but for years all new assignments have been of the 3-letter variety. The capacity of the alphabet in 2-letter calls was exhausted long ago. Even when one amateur license lapses due to death or other cause it is not reassigned because thousands of amateurs would want it and there is no basis for favoring one of many.

(\*) Broadcast-station call letters were analyzed in "F. C. C.—Radio Call Letters," in the Oct. 1940 issue of Radio-Craft, pg. 230.



**"STRATOLINER" CRYSTAL MIKE**

Shure Brothers  
225 W. Huron St., Chicago, Ill.



THE model 708A "Stratoliner" is a crystal mike with a high output level (49.7 db. below 1 volt per bar at end of 7 ft. cable). It uses a moisture-sealed Bimorph crystal, mechanically isolated. Semi-directional or non-directional operation may be obtained.—Radio-Craft

**NEW OSCILLOSCOPE**

Mickok Elec. Instrument Co.  
419 Erie Bldg., Cleveland, Ohio



DESIGNED for servicing F.M. and television receivers. The instrument offers single or consecutive stage-by-stage trouble-shooting from antenna post to speaker. Has self-contained, wide-band F.M. oscillator and narrow-band F.M. oscillator. Also contains demodulator, video amplifiers, signal tracer circuit and visual A.C. vacuum-tube voltmeter with a range of from 0.2- to 1,000 volts. The wide-band F.M. oscillator can be modulated from external sources.—Radio-Craft

row-band F.M. oscillator. Also contains demodulator, video amplifiers, signal tracer circuit and visual A.C. vacuum-tube voltmeter with a range of from 0.2- to 1,000 volts. The wide-band F.M. oscillator can be modulated from external sources.—Radio-Craft

**POLY-DIRECTIONAL MICROPHONE**

Electro-Voice Mfg. Co., Inc.  
1239 South Bend Ave., South Bend, Ind.

KNOWN as Cardak model 725, this microphone has a constantly-variable sound pick-up pattern, enabling the operator to select the correct directivity for each particular installation. A screwdriver control allows the microphone to function as a true cardioid or as a bi-directional instrument, making it an ideal microphone for orchestras, traveling with their own sound systems, which may encounter many acoustical problems. Response is said to be "substantially flat" from 30 to 10,000 cycles. Sensitivity is -52 db. 1 volt/bar (average level).—Radio-Craft

**UNIVERSAL DOUBLE-TUNED I.F. TRANSFORMERS**

Radex Corp.  
1733 Milwaukee Ave., Chicago, Ill.

A SET of the type 5170A, -B, and -C Radex double-tuned I.F. transformers, in ranges covering, respectively, 150-200 kc., 240-300 kc., 430-500 kc., are said to enable Servicemen to replace input, interstage or output I.F. transformers of practically every description.—Radio-Craft

**CARBOTET FIRE EXTINGUISHER**

The Fertilist Corporation  
Westport, Conn.

AN entirely new type of fire extinguisher designed for the low-priced field. Every service shop should carry several of these for the protection of their customers' receivers. Made in hand-gun and automatic types.

The device is a hermetically-sealed unit which does not require periodic attention or refilling. It lasts indefinitely or until used. The liquid chemical, carbon tetrachloride, does not stain; and is effective against oil, gasoline and electrical fires where water or soda-acid is either useless or dangerous. Throws stream 15 to 20 ft.—Radio-Craft

**NOISE FILTERS FOR HOME APPLIANCES AND FLUORESCENT LAMPS**

Cornell-Dubilier Electric Corp.  
South Plainfield, N. J.



THESE "Quietone" units are designed to mount directly on the offending home-appliance (and fluorescent lamps in particular). There are two insulated flexible leads that are connected across the supply line, either inside the appliance or where the line enters. Available for 110-volt A.C. or D.C. or for 220-volt A.C. or D.C. operation. Both units are entirely shielded in metal containers.—Radio-Craft

**PAGING & INTERPHONE SYSTEM**

Webster-Chicago Corporation  
5622-5660 Bloomingdale Ave., Chicago, Ill.



THE model W-300 series instrument is a combined paging and intercommunication system whereby the central master station can contact either one or all remote stations, up to 18, simultaneously or carry on a 2-way conversation with each station. Remote stations are also able to originate calls.—Radio-Craft

**PORTABLE PHONOGRAPH**

Dynavox  
55 E. 11th St., New York, N. Y.



MODEL 501 portable electric phonograph with built-in amplifier. A heavy-duty motor and crystal pickup are employed. Designed for 110-120 volt, 60-cycle A.C. operation.—Radio-Craft

**DYNAMIC PHONO PICKUP**

Sound Apparatus Co.  
150 W. 56th St., New York, N. Y.

FOLLOWING are the features of this new electrodynamic-type phono pickup. Frequency response essentially flat from 30 to 9,000 cycles. Needle pressure only about 1 oz. or less. Output level 5 volts per 1 cm./sec. Needle impedance about 12 gr. for an amplitude of 0.065-mm. Electrical impedance is 200 ohms; other impedances are available.—Radio-Craft

**RADIO NOISE AND FIELD-STRENGTH METER**

Ferris Instrument Corp.  
Boonton, N. J.

THE model 32 radio noise and field-strength meter provides a means for locating, and quickly and accurately measuring, all kinds of radio interference fields. This radio-frequency microvoltmeter is sufficiently accurate for station field surveys.—Radio-Craft

**SHORT-INTERVAL ELECTRONIC TIMER**

Photoswitch, Inc.  
21 Chestnut St., Cambridge, Mass.

A NEW timer is available with intervals from 1/20 sec. to 2 mins. Control is through a snap-action relay with 1,000 W. capacity. Special "timing valves" (grid leaks which gradually discharge a condenser) snap into clips to establish any one of 6 timing ranges.—Radio-Craft

**DISTORTION-MEASURING SET**

The Hewlett-Packard Co.  
481 Page Mill Rd., Palo Alto, Calif.

THE type 320A distortion-measuring set may be used with any signal generator and oscilloscope to give distortion readings at 2 different frequencies. Suitable for radio stations, laboratories, public address operators and maintenance men. Frequency range: standard, 400-5,000 cycles; special, 50-10,000 cycles. The device compares the distortion component with the fundamental voltage.—Radio-Craft

# •LATEST RADIO APPARATUS•

## 1,000 OHMS/VOLT RECORDING VOLTMETER

The Esterline-Angus Co., Inc.  
Indianapolis, Ind.

**T**HIS new supersensitive 1,000 ohms/volt recorder is a compact, portable high-speed graphic meter which finds application in telephone, telegraph, radio, television and carrier current fields. Voltages are recorded by a direct-action pen on a continuously-moving paper strip 6 ins. wide. May be used, with an amplifier, to record sound, vibration, light intensity, radio field-strength, etc. Has a "Formex"-wire coil in an Alnico-magnet field.

## MARINE-GENERATOR RADIO INTERFERENCE FILTER

J. W. Miller Co.  
5917 S. Main St., Los Angeles, Calif.

**T**HE new type 7859 radio interference filter has been designed primarily for use with marine generators to avoid commutator interference. Unit is said to use the largest duolateral-wound chokes ever made; includes a special shunt field section rated at 30 A.; and has four 2-mf. condensers.—*Radio-Craft*

## JUNIOR-TYPE MARINE PHONE

Hallicrafters

2611 S. Indiana, Chicago, Ill.

**T**HE model HT-11 marine radiophone has been introduced to meet demands for a communications device for small boats. It covers broadcast and marine radiophone bands. Measures only 14½ x 8½ x 9¼ ins. Available for 6 V., 12 V., 32 V. or 110 V. operation. Output, 12 W. Has hand-set and standby loudspeaker.—*Radio-Craft*

## NEW VOLUME CONTROL CABINET

International Resistance Co.  
401 North Broad St., Philadelphia, Pa.



**E**IGHTEEN type D all-purpose volume controls together with 6 switches and 5 special tap-in shafts, located in a neat metal cabinet, provide for 60% to 75% of all volume control replacements. Cabinet is decorated to enhance the appearance of service shops, measures 14½ x 7¾ x 4¼ ins. deep.—*Radio-Craft*

## NEW-TYPE SPEAKER

RCA Manufacturing Co., Inc.  
Camden, N. J.

**A** NEW 15¼-in. high-fidelity loudspeaker mechanism, known as model MI-6237, is available either separately or with wall housing or console cabinet. The P.M. dynamic speaker handles 15 watts of power and is recommended for reproducing phonograph recordings or other sound under conditions of high noise level. The voice coil (impedance 8 ohms) is completely dust-proof. The console cabinet stands 32 ins. high, 24 ins. wide and 14 ins. deep, and has

an "acoustic phase-inverter circuit" built into the cabinet to extend low-frequency response.—*Radio-Craft*

## "PADGET" AND "QUADGET"

Norman B. Neely

5334 Hollywood Blvd., Hollywood, Calif.

**T**HESE high-sounding names are supposed to describe 2 new calculating devices, one (the Padget) enabling the user to determine the resistors required for attenuators without resorting to extended calculations; and the other (the Quadget) intended to simplify the design of constant-impedance equalizers, specifically for 500-ohm circuits. However, it is possible with both of these calculators to do engineering calculations for various other circuits.

Each calculator is simply a cardboard sheet sliding in and out of a cardboard sleeve. The outer sleeve has perforated windows at predetermined places where the desired figures appear. Both are handy units indeed.—*Radio-Craft*

## MULTI-USE TABLE-TYPE "RADIOCODER"

Radio Wire Television, Inc.  
100 6th Ave., New York, N. Y.

**K**NOWN as model JS-176, this table instrument combines the functions of radio, phonograph, recorder and public-address system. The phonograph pickup is of the tangent-arm crystal type. A separate crystal recorder head and arm are used in conjunction with a constant-speed heavy-duty motor and 10-in. turntable for recording. A neon dual-glow lamp indicates proper recording level. The receiver is a 9-tube 3-band superheterodyne, with built-in adjustable loop antenna, tuning "eye", push-pull output, crystal microphone and 1-stage preamplifier, as well as other features. Broadcast range to 1,680 kc., short-wave ranges 2.25 to 7 and 7.5 to 24 megacycles.—*Radio-Craft*

## NEW SYNCRO-SOUND SYSTEM FOR MAKING HOME SOUND-FILMS

Presto Recording Corp.  
242 W. 55th St., New York, N. Y.

**T**HIS new system makes it possible to produce 8 mm. or 16 mm. talking pictures at about 1/10th the cost of sound-film productions, according to the manufacturer. It maintains almost perfect "lip synchronization" between sound-on-disc recordings and silent films. Used in conjunction with a Presto recorder and an ordinary silent projector, the equivalent of a talking picture film is obtained.—*Radio-Craft*

## RADIAL CONE SPEAKER PROJECTOR

University Laboratories  
195 Christie St., New York, N. Y.

**B**ECAUSE it resembles a lighthouse when it stands on end, this unit has been termed "Lighthouse" projector. The difference from previous radial cone projectors is the fact that double the usual acoustic length is employed, making for good low-frequency response. Other features include floating rubber cone speaker mounting, radial acoustic breather, non-resistant rubber-tire rims. It is claimed that the design of the bells provides uniform 360° sound projection. Bell diameter 24 ins., overall height 28 ins. Designed for 12-in. cone speakers.—*Radio-Craft*

## NEW F.M. AND TELEVISION CABLE

Belden Manufacturing Co.  
4689 W. Van Buren St., Chicago, Ill.



**A** NEW high-frequency transmission cable, of the 100-ohm twisted-pair type, known as No. 8219. Consists of 18-gauge stranded tinned copper wire, properly insulated and shielded for F.M. and television use. Outside diameter is 0.350-in. The No. 8218, without outer tinned copper shield, is 2.7 in. in dia.—*Radio-Craft*

## ALL-TRIODE AMPLIFIER

General Communication Products Co.  
6245 Lexington Ave., Hollywood, Calif.

**A** HIGH-GAIN, wide-range amplifier, known as model GCP-12A. Nine amplifiers available in this series, differing only in the number of input channels and the gain in the phono channel. Has a rated output of 12 watts and a peak output of 24 watts. To minimize output distortion, triode tubes are used in all stages, including push-pull output.—*Radio-Craft*

## COUNTER-TYPE TUBE MERCHANDISER

Precision Apparatus Co.  
647 Kent Ave., Brooklyn, N. Y.

**A** STREAMLINED tube tester and set analyzer with a swivel-mounted, large 7-in. easy-reading meter. The instrument is known as series 914. It provides a full view of test results from all positions since the meter can be moved in any direction.—*Radio-Craft*

## "WIRELESS" RECORD CHANGER

The Talk-A-Phone Mfg. Co.  
520 North Michigan Ave., Chic go, Ill.

**T**HE instrument incorporates an automatic record changer which plays ten 12-in. or twelve 10-in. records with each loading. A 78 r.p.m. rim-drive motor and crystal pickup are used. The 2-tube "wireless" oscillator housed inside the case will operate with any radio receiver. The cabinet measures 21x16½x12¼ ins. high. Designed for operation from a 110-120 volt, 60-cycle A.C. line.—*Radio-Craft*

## NEWS SHORTS

Regal Amplifier Manufacturing Company recently announced to radio Servicemen and dealers a complete line of their famous "Tok Fone" brand all-purpose sound systems, including standard amplifiers in an exceptionally low price range.

They have a very interesting bulletin covering all types of record players, amplifiers, intercommunication systems and items dealing in the sound field.

Any Serviceman, dealer or sound man may write and receive their catalog upon request to the manufacturers or in care of *Radio-Craft*.

The 1940 Presidential Election, now history, may be credited with having introduced the Public Address Trailer. The one noted by this writer consisted of 2 Roosevelt-Wallace signs in inverted-V formation and surmounted by trumpets pointing in 4 directions, on a trailer being pulled by a private sedan; the location of the amplifier was not evident, but it may have been a self-powered assembly underneath the trailer signs.



Where to Buy It! —

# CLASSIFIED RADIO DIRECTORY

Handy Buying Guide, by Products and Manufacturers' Names and Addresses, for the Entire Radio Industry

This DIRECTORY is published in sections—1 section per month. This method of publication permits the DIRECTORY to be constantly up-to-date since necessary revisions and corrections can be made monthly. All names preceded by an asterisk (\*) indicate that they are trade names.

If you cannot find any item or manufacturer in this section or in previously-published sections, just drop us a line for the information.

Section I of this DIRECTORY was published in the October, 1940 issue. Presented here is Section IV.

While every precaution is taken to insure accuracy, Radio-Craft cannot guarantee against the possibility of occasional errors and omissions in the preparation of this Classified Directory. Manufacturers and readers are urged to report all errors and omissions at the earliest moment to insure corrections in the very next issue.

## RECORDING EQUIPMENT



- Combination public-address-recording amplifiers . . . CPA
- Combination radio-recorders CR
- Cutting heads (lateral & vertical cut) . . . . . CH
- Discs (blank) . . . . . D
- Equalizers . . . . . E
- Lead-screws (recording & playback) . . . . . LS
- Magnetic-tape recorders . . . MT
- Motors . . . . . M
- Needles (recording) . . . . . N
- Recording machines . . . . . RM
- Recording machine assem. (cutter, pickup, motor, turntable) RA
- Recording supplies (record preservers, etc.) . . . . . RS
- Sound-on-film recorders . . . SFR
- Transcription equipment . . . TE
- Turntable flocks . . . . . TTF

- ACOUSTIC EQUIPMENT CO., 323 Walton Bldg., Atlanta, Ga.—TE
- \*ACTONE—H. W. ACTON CO., INC. H. W. ACTON CO., INC., 370 7th Ave., New York, N. Y., \*\*Actone"—N
- AIR KING PRODUCTS CO., INC., 1523 63rd St., Brooklyn, N. Y., \*\*Air King"—RM
- ALLIANCE MFG. CO., Alliance, Ohio—RA
- ALLIED RECORDING PRODUCTS CO., 21-09 43rd Ave., Long Island City, N. Y.—CH, D, M, N, RM, RS, LS, TT
- AMPLIFIER CO. OF AMERICA, 17 W. 20th St., New York, N. Y.—CPA, CR, TE, RA, E
- AMPLITONE PRODUCTS CO., 135 Liberty St., New York, N. Y.—CH, D, M, N, RM, RS, LS, TT
- ANSLEY RADIO CORP., 4377 Bronx Blvd., New York, N. Y.—CR
- ASTATIC MICROPHONE LABORATORY, INC., 830 Market St., Youngstown, O.—CH, E, N
- AUDIO DEVICES, INC., 1600 Broadway, New York, N. Y., \*\*Audioclips", \*\*Audiopoints"—D, N, RS
- AUDIOGRAPH SOUND SYSTEMS, 1313 W. Randolph St., Chicago, Ill.—CR, CPA, CH, TE
- \*AUDIODISCS—Audio Devices, Inc.
- \*AUDIOPOINTS—Audio Devices, Inc.
- \*AUDIOGRAPH—John Meck Industries
- BANK'S MFG. CO., 5019 N. Winthrop Ave., Chicago, Ill.—CR, CPA
- BATEMAN SOUND SYSTEMS, 680 Johnston St., Akron, Ohio—RM, RS, LS, TT
- \*BELFONE—BELL SOUND SYSTEMS, INC. BELL SOUND SYSTEMS, INC., 1183 Essex Ave., Columbus, Ohio, \*\*Belfone"—D, N, RM
- DAVID BOGEN CO., INC., 663 Broadway, New York, N. Y.—RM
- BROWN ELECTRIC CO., 65 Atlantic Ave., Rochester, N. Y.—CH, RM, TT
- THE BRUSH DEVELOPMENT CO., 3311 Perkins Ave., Cleveland, Ohio—CH
- CARRON MFG. CO., 415 S. Aberdeen St., Chicago, Ill.—N, RA, D
- CRUMPACKER DISTRIBUTING CORP., 1801 Fannin St., Houston, Texas—CR, CPA, N, D
- THE DAVEN COMPANY, 158 Summit St., Newark, N. J.—E

- DE VRY CORPORATION, 1111 Armitage Ave., Chicago, Ill.—RM, RS, CPA
- DUPLEX RECORDING DEVICES CO., 514 W. 36th St., New York, N. Y.—M, RM, RS, LS, TT
- \*DURALITE—Musicraft Records, Inc.
- ELECTRONIC APPLICATIONS, Brunswick, Maine—E
- ELECTRICAL INDUSTRIES MFG. CO., Red Bank, N. J.—CH, D, M, N, RM, RS, LS, TT
- ESPEY MFG. CO., INC., 305 E. 63rd St., New York, N. Y.—CR
- FAIRCHILD AERIAL CAMERA CORP., 88-06 Van Wyck Blvd., Jamaica, L. I., N. Y., \*\*Fairchild"—CH, D, N, RM, RS, TT
- FARNSWORTH TELEVISION & RADIO CORP., 2702 E. Pontiac St., Fort Wayne, Ind.—CR
- FEDERAL RECORDER CO., INC., 50 W. 57th St., New York, N. Y.—D, N, RM
- FISCHER DISTRIBUTING CORP., 222 Fulton St., New York, N. Y.—CR, CPA, CH, TE, RA, E, N, RS, D
- FLEX RECORD CO., 9 Rockefeller Plaza, New York, N. Y.—D, N, RM, RS
- FLOCK PROCESS CORP., 17 W. 31st St., New York, N. Y.—TTF
- GENERAL CEMENT MFG. CO., 919 Taylor Ave., Rockford, Ill.—D, N, RS
- GENERAL COMMUNICATIONS PRODUCTS CO., 6245 Lexington Ave., Hollywood, Calif.—CPA, CH
- GENERAL ELECTRIC CO., Schenectady, N. Y., & Bridgeport, Conn.—CR
- GENERAL INDUSTRIES CO., 3537 Taylor St., Elyria, Ohio—M, TT
- M. A. GERETT CORP., 2947 N. 30th St., Milwaukee, Wis.—N
- HAMMOND MANUFACTURING CO., Guelph, Ontario, Canada—E
- HARRISON RADIO CO., 12 W. Broadway, New York, N. Y.—CR, CPA, TE, RA, E, N, D, RS
- HERBERT H. HORN, 1201 S. Olive St., Los Angeles, Calif.—CR, TE, N, D
- HOWARD RADIO CO., 1735 Belmont Ave., Chicago, Ill.—CR, D, N
- INSULINE CORP. OF AMERICA, 30-30 Northern Blvd., Long Island City, N. Y.—D, N
- J. F. D. MFG. CO., 4111 Fort Hamilton Pkwy., Brooklyn, N. Y.—D, N, RS
- LAFAYETTE RADIO CORP., 100 6th Ave., New York, N. Y.—CR, CPA, TE, RA, E, N, CH, D, RS
- LOWELL NEEDLE CO., INC., Putnam, Conn.—M & H SPORTING GOODS CO., 512 Market St., Phila., Pa.—CR, CPA, N, CH, D, RS
- MAJESTIC RADIO & TELEVISION CORP., 2600 W. 50th St., Chicago, Ill.—CR, CPA, D
- JOHN MECK INDUSTRIES, 1313 W. Randolph St., Chicago, Ill., \*\*"Audiograph"—CH, RM
- MEISSNER MANUFACTURING CO., Mt. Carmel, Ill.—CR
- MELLAPHONE CORP., 65 Atlantic Ave., Rochester, N. Y.—CH, RA
- CHARLES MICHELSON ELECTRICAL TRANSCRIPTIONS, 67 W. 44th St., New York, N. Y.—TE
- MILES REPRODUCER CO., INC., 812 Broadway, New York, N. Y.—D, N, CPA, CH, TE, RA, E
- MIRROR RECORD CORP., 58 W. 25th St., New York, N. Y.—N, D, RS
- MONTGOMERY WARD & CO., 619 W. Chicago Ave., Chicago, Ill.—CR, CPA, TE, RA, E, N, CH, D, RS
- MUSICRAFT RECORDS, INC., 10 W. 47th St., New York, N. Y., \*\*"Duralite"—D, N
- MUSIC MASTER MFG. CO., 508 S. Dearborn St., Chicago, Ill.—CR, TE, RA, D, N
- NASH RADIO PRODS. CO., 6267 Gravois Ave., St. Louis, Mo.—M, N, RS
- PACENT ENGINEERING CORP., 79 Madison Ave., New York, N. Y.—CR, CPA, RA

- PEERLESS ALBUM CO., INC., 38 W. 21st St., New York, N. Y.—N, D
- \*PERMO POINT—Permo Products Corp.
- PERMO PRODUCTS CORP., 6415 Ravenswood Ave., Chicago, Ill., \*\*Permo Point"—N, RS
- PHILCO RADIO & TELEVISION CORP., Phila., Pa.—CR, N, CH, D
- PHONOGRAPH NEEDLE MFG. CO., INC., 42-46 Dudley St., Providence, R. I.—N
- PHONOTONE LABORATORIES, INC., S.E. 15th St., Washington, Ind.—CR, CPA, CH, TE, RA, E, D, N, RS
- \*POINSETTIA, INC., Pitman, N. J. — RM, RS, CH
- PRESTO RECORDING CORP., 242 W. 55th St., New York, N. Y., \*\*Presto"—CR, CPA, CH, TE, RA, E, D, N
- RADIO ELECTRIC SERVICE CO., INC., N.W. Cor. 7th & Arch Sts., Phila., Pa.—CPA, CR, CH, TE, RA, E, D, N, RS
- RADIO ENGINEERING LABS., INC., 35-54 36th St., Long Island City, N. Y.—TT
- RADIOTONE, INC., 7356 Melrose Ave., Hollywood, Calif.—CH, D, N, RM, RS, LS, TT, CR, CPA, TE, RA, E
- RANGERTONE, INC., 201 Verona Ave., Newark, N. J.—D, N, RM
- RCA MFG. CO., Frost & Cooper Sts., Camden, N. J., \*\*"RCA"—D, M, N, RM, RS, LS, TT, CR, CPA, TE, E, RA
- RECOTON CORPORATION, 178 Prince St., New York, N. Y.—N
- REGAL AMPLIFIER MFG. CORP., 14 West 17th St., New York, N. Y.—CPA
- REK-O-KUT CORP., 254 Canal St., New York, N. Y.—M, N, RM, LS, TT
- REMLER CO., LTD., 2101 Bryant St., San Francisco, Calif., \*\*Remler"—RM, CR
- ROCK-OLA MANUFACTURING CORP., 800 No. Kedzie Ave., Chicago, Ill.—CR
- ROWE INDUSTRIES, INC., 3120 Monroe St., Toledo, O.—CPA
- MAURICE SCHWARTZ & SON, 710-712 Broadway, Schenectady, N. Y.—CR, CPA, TE, RA, E, N, C, CH, D
- SELECTAR MFG. CORP., 30 W. 15th St., New York, N. Y.—CPA, CH, RA, TE, D, N
- SENTINEL RADIO CORP., 2020 Ridge Ave., Evans-ton, Ill.—CR, CPA, N, D
- SKY CHIEF RADIO CORP., 345 E. 27th St., New York, N. Y.—CR
- S.O.S. CINEMA SUPPLY CORP., 636 11th Ave., New York, N. Y.—SFR
- SOUND APPARATUS CO., 150 W. 46th St., New York, N. Y.—CH, D, M, N, RM, RS, TT, CR, CPA, CH, TE, RA, E
- SOUND DEVICES CO., 160 E. 116th St., New York, N. Y.—D
- SPEAK-O-PHONE RECORDING & EQUIPMENT CO., 23 W. 60th St., New York, N. Y., \*\*Speakophone"—CH, D, M, N, RM, RA, RS, TT, CPA, CR, TE
- SUN RADIO CO., 212 Multon St., New York, N. Y.—CPA, CR, CH, TE, RA, E, D, N, RS
- TALK-A-PHONE MFG. CO., 1219 W. Van Buren St., Chicago, Ill.—CPA, RA
- TALKING DEVICES CO., 4451 Irving Park Blvd., Chicago, Ill.—CH
- THORDARSON ELECTRIC MFG. CO., 500 W. Huron St., Chicago, Ill., \*\*Thordarson"—E
- TRANSFORMER CORP. OF AMERICA, 69 Wooster St., New York, N. Y.—CPA, TE, E
- UNITED TRANSFORMER CORP., 150 Varick St., New York, N. Y.—RPA, E
- UNIVERSAL MICROPHONE CO., Inglewood, Calif.—CH, D, M, N, RM, RS, LS, TT
- VIBRALOC MFG. CO., 1273 Mission St., San Francisco, Calif.—RM
- J. J. WARNER CO., 1244 Larkin St., San Francisco, Calif.—CH, D, RM, RS, LS, TT
- THE WEBSTER-CHICAGO CORP., 5622 W. Bloom-ingdale Ave., Chicago, Ill., \*\*Webster-Chicago"—CPA, RA, D

# CLASSIFIED RADIO DIRECTORY

WEBSTER ELECTRIC CO., Clark & DeKane Ave., Racine, Wis.—N, CH  
 WESTERN SOUND & ELECTRIC LABS., INC., 311 W. Kilbourn Ave., Milwaukee, Wis.—RM, CPA  
 WILCOX ELECTRIC CO., INC., 4014 State Line, Kansas City, Kans.—CH

## RESISTORS & VOLUME CONTROLS (ATTENUATORS & NETWORKS)



Attenuators & networks (precision)	A
Fixed composition	FC
Fixed wirewound	FW
Industrial fixed	I
Plug-in (tubes)	PT
Power rheostats	PR
Precision	PRE
Special purpose	SP
Suppressors	SU
Volume control shields	VCS
Variable	V
Volume controls	VC

AEROVOX CORPORATION, 740 Belleville Ave., New Bedford, Mass.—FC, FW  
 ALLEN-BRADLEY CO., 1326 South 2nd St., Milwaukee, Wis., \*Bradleyunit, \*Bradleyometer—FC, SU, V, VC  
 ALLIED RADIO CORP., 833 W. Jackson Blvd., Chicago, Ill., \*Knight—FC, FW, SU, V, VC, A, I, PT, PR, PRE  
 AMPERITE COMPANY, 561 Broadway, New York, N. Y., \*Amperite—PT  
 ARCO TUBE CO., 227 Central Ave., Newark, N. J.—PT  
 ARCTURUS RADIO TUBE CO., 720 Frelinghuysen Ave., Newark, N. J., \*Arcturus—PT  
 ATLAS RESISTOR CO., 423 Broome St., New York, N. Y., \*Atlas—FW, V  
 BOND PRODUCTS CO., 13139 Hamilton Ave., Detroit, Mich.—SU, V, VC  
 \*BRADLEYOMETER—Allen-Bradley Co.  
 \*BROWN DEVIL—Ohmite Mfg. Co.  
 \*CANDOHMS—Muter Co.  
 CENTRALAB, 900 E. Keefe Ave., Milwaukee, Wis., \*CENTRALAB—A, FC, PR, SU, V, VC  
 CHAMPION RADIO WORKS, Danvers, Mass.—PT  
 CHICAGO TELEPHONE SUPPLY CO., 1142 W. Beardsley Ave., Elkhart, Ind.—V, VC  
 CINEMA ENGINEERING CO., 1508 S. Verdugo Ave., Burbank, Calif., \*Cinema—A, FW, I, PR, PRE, V, VC  
 CLAROSTAT MFG. CO., 285 N. 6th St., Brooklyn, N. Y., \*Clarostat—A, FC, FW, I, PT, PR, PRE, V, VC  
 CONSOLIDATED WIRE & ASSOC. CORP., Peoria & Harrison Sts., Chicago, Ill.—FC, FW, V, VC, SU, I  
 CONTINENTAL CARBON, INC., 13900 Loraine Ave., Cleveland, Ohio, \*Continental—FC, FW, PRE, SU, I  
 \*CORDOHM—Ohmite Mfg. Co.  
 CRUMPACKER DISTRIBUTING CORP., 1801 Fannin St., Houston, Texas—FC, FW, SR, VC  
 DAVEN COMPANY, 158 Summit St., Newark, N. J.—A, FW, PRE, VC, PR  
 \*DEPENDABLE—Radio City Products Co., Inc. DE VRY CORP., 1111 Armitage Ave., Chicago, Ill.—FW, I, PR, VC  
 \*DIVIDOHM—Ohmite Mfg. Co.  
 ELECTRO-MOTIVE MFG. CO., INC., 5 Park & John Sts., Willimantic, Conn., \*Elmenco—FC, SU  
 ELECTRO PRODUCTS LABORATORIES, 549 W. Randolph St., Chicago, Ill.—VC  
 \*ELMENCO—Electro-Motive Mfg. Co., Inc.  
 ERIE CAN CO., 816 Erie St., Chicago, Ill.—VCS  
 ERIE RESISTOR CORP., 644 W. 12th St., Erie, Pa.—FC, SU  
 \*EX-STAT—Tilton Electric Corp.  
 GENERAL CEMENT MFG. CO., 919 Taylor Ave., Rockford, Ill.—SU  
 GENERAL ELECTRIC CO., Schenectady, N. Y., & Bridgeport, Conn.—FW, I, PR, V  
 GENERAL RADIO CO., 30 State St., Cambridge, Mass., \*G-R—PRE, A, FW, V, VC  
 \*G-H—Girard-Hopkins  
 GIRARD-HOPKINS, 1437 23rd Ave., Oakland, Calif., \*G-H—FC  
 GLOBAR DIV., CARBORUNDUM CO., Niagara Falls, N. Y., \*Globar—FC, I  
 \*G-R—General Radio Co.  
 HARDWICK & HINDLE, INC., 40 Herman St., Newark, N. J.—FW, I, PR, PRE, V  
 HARRISON RADIO CO., 12 W. Broadway, New York, N. Y.—A, FC, FW, I, PR, PRE, V, VC  
 HYGRADE-SYLVANIA CORP., Emporium, Pa., \*Sylvania—PT  
 HYTRON CORPORATION, 76 Lafayette St., Salem, Mass., \*Hytron—PT

\*ICA—Insuline Corp. of America  
 INSTRUMENT RESISTORS, INC., 25 Amity St., Little Falls, N. J.—A, FW, I, PRE, V  
 INSULINE CORP. OF AMERICA, 30-30 Northern Blvd., Long Island City, N. Y., \*ICA—FW, PRE, SU, V, VC  
 \*IRC—International Resistance Co.  
 INTERNATIONAL RESISTANCE CO., 401 N. Broad St., Philadelphia, Pa., \*IRC—A, FC, FW, I, PR, PRE, SU, V, VC  
 J. F. D. MFG. CO., 4111 Ft. Hamilton Pkwy., Brooklyn, N. Y., \*JFD—PT, SU  
 \*KNIGHT—Allied Radio Corp.  
 \*KOOLOHMS—Sprague Products Co.  
 LAFAYETTE RADIO CORP., 100 6th Ave., New York, N. Y.—A, FC, FW, I, PT, PR, PRE, SU, V, VC  
 LECTROHM, INC., 5133 W. 25th Place, Cicero, Ill.—FW, I, V  
 LEEDS & NORTHRUP CO., 4970 Stenton Ave., Phila., Pa.—A, PRE  
 M & H SPORTING GOODS CO., 512 Market St., Phila., Pa.—A, FC, FW, I, PT, PR, PRE, SU, V, VC  
 P. R. MALLORY & CO., INC., 3029 E. Washington St., Indianapolis, Ind., \*Yaxley—A, FC, FW, V, VC  
 MICAMOLD RADIO CORP., 1087 Flushing Ave., Brooklyn, N. Y.—FW, PT  
 \*MICROHM—Precision Resistor Co.  
 MONTGOMERY WARD & CO., 619 W. Chicago Ave., Chicago, Ill.—FC, FW, PR, SU, V, VC  
 MORRILL & MORRILL, 30 Church St., New York, N. Y.—PRE  
 \*MULTIVOLT—Ohmite Mfg. Co.  
 NATIONAL ELECTRIC CONTROLLER CO., 5307 Ravenswood Ave., Chicago, Ill.—PR  
 MUTER COMPANY, 1255 S. Michigan Ave., Chicago, Ill., \*Candohms, \*Zipohms—FW, PT  
 OHIO CARBON CO., 12508 Berea Rd., Cleveland, Ohio—FC, FW, SU  
 OHMITE MFG. CO., 4835 W. Flournoy St., Chicago, Ill., \*Ohmite, \*Red Devil, \*Brown Devil, \*Multivolt, \*Riteohm, \*Cordohm, \*Dividohm—FW, I, PT, PR, PRE, V  
 \*OHMSPUN—States Co.  
 PHILCO RADIO & TELEVISION CORP., Tioga & C Sts., Phila., Pa.—SU, V, VC, A  
 PRECISION RESISTOR CO., 334 Badger Ave., Newark, N. J., \*Microhm—FW, I, PRE  
 RADIO CITY PRODUCTS CO., INC., 88 Park Pl., New York, N. Y., \*Dependable—PRE  
 RADIO ELECTRIC SERVICE CO., INC., N.W. Cor. 7th & Arch Sts., Phila., Pa.—A, FC, FW, I, PT, PR, PRE, SU, V, VC  
 RADIO WIRE TELEVISION, INC., 100 Sixth Ave., New York, N. Y., \*Trutest—FC, FW, V, VC  
 RADOLEK COMPANY, 601 W. Randolph St., Chicago, Ill., \*Radolek—A, FC, FW, I, PT, PR, PRE, SU, V, VC  
 RAYTHEON PRODUCTION CORP., 55 Chapel St., Newton, Mass.—PT  
 RCA MFG. CO., INC., Camden, N. J.—A  
 READRITE METERS WORKS, 136 E. College Ave., Bluffton, Ohio, \*Readrite—PRE  
 \*RED DEVIL—Ohmite Mfg. Co.  
 REMLER CO., LTD., 2101 Bryant St., San Francisco, Calif., \*Remler—A  
 REX RHEOSTAT CO., 37 W. 20th St., New York, N. Y.—FW, I, PR, V  
 \*RITEOHM—Ohmite Mfg. Co.  
 MAURICE SCHWARTZ & SON, 710-712 Broadway, Schenectady, N. Y.—A, FC, FW, I, PT, PR, PRE, SU, V, VC  
 SHALLCROSS MFG. CO., 10 Jackson Ave., Collingdale, Pa., \*Shallcross—A, PRE  
 SPEER RESISTOR CORP., St. Marys, Pa.—FC, FW, SU  
 SPRAGUE PRODUCTS CO., N. Adams, Mass., \*Koolohms—FW, I, PRE  
 STACKPOLE CARBON CO., Tannery St., St. Marys, Pa., \*Stackpole—FC, SU, VC  
 STATES COMPANY, 19 New Park Ave., Hartford, Conn., \*Ohmspan—FW  
 SUN RADIO CO., 212 Fulton St., New York, N. Y.—A, FC, FW, I, PT, PR, PRE, SU, V, VC  
 \*SYLVANIA—Hygrade-Sylvania Corp.  
 TECH LABORATORIES, 7 Lincoln St., Jersey City, N. J., \*Tech Lab—A, PRE, VC  
 TILTON ELECTRIC CORP., 15 E. 26th St., New York, N. Y., \*Ex-Stat—FC, FW, SU, V, VC  
 TRIAD MFG. CO., INC., Blackstone & Fountain Sts., Pawtucket, R. I., \*Triad—PT  
 TRIPLETT ELECTRICAL INSTRUMENT CORP., 122 Main St., Bluffton, Ohio, \*Triplet—PRE  
 \*TRUTEST—Radio Wire Television, Inc.  
 UTAH RADIO PRODUCTS CO., 820 Orleans St., Chicago, Ill.—FC, FW  
 WARD LEONARD ELECTRIC CO., 31 South St., Mount Vernon, N. Y.—FW, I, PR, V  
 THE WARD PRODUCTS CORP., 1523 E. 45th St., Cleveland, Ohio—SU

WESTON ELECTRICAL INSTRUMENT CORP., Newark, N. J.—PRE  
 S. S. WHITE DENTAL MFG. CO., 10 E. 40th St., New York, N. Y.—FC  
 WIRT COMPANY, 5221 Greene St., Phila., Pa., \*Wirtco Phenocote—FC, FW, I, SU, V, VC  
 \*WIRTCO PHENOCOTE—Wirt Co.  
 \*YAXLEY—P. R. Mallory & Co., Inc.  
 \*ZIPOHMS—Muter Co.

## SCHOOLS



Residence	RO
Correspondence	C
Tuition fee is charged	TC
Free tuition	FT
<b>SUBJECTS TAUGHT:</b>	
Aviation	A
Broadcasting	B
Communications (Land and Marine)	LMC
Course for B. Sc. in Radio Engineering	BRE
Electronics	E
Facsimile	F
Frequency Modulation	FM
Military radio	MR
Radio engineering	RE
Servicing	S
Sound	SO
Sound motion pictures	SMP
Television	TL
Other radio courses	ORC

AMERICAN RADIO INSTITUTE, 1123 Broadway, New York, N. Y.—R, C, TC, ORC  
 THE AMERICAN SCHOOL, 850 E. 58th St., Chicago, Ill.—C, TC, S, TL, RE  
 BECK SCHOOL FOR RADIO, Keith Bldg., 1722 Hennepin Ave., Minneapolis, Minn.—R, TC, B, ORC  
 THE CANDLER SYSTEM CO., Asheville, N. C.—C, TC, ORC  
 CASE SCHOOL OF APPLIED SCIENCE, Cleveland, Ohio—R, TC, E, RE, OTC  
 CHICAGO TECHNICAL COLLEGE, 118 E. 26th St., Chicago, Ill.—R, TC, S, B, E, TL, RE  
 DE FOREST'S TRAINING, INC., 2533 N. Ashland Ave., Chicago, Ill.—R, C, S, B, A, LMC, E, TL, RE, SMP  
 DODGE'S TELEGRAPH & RADIO INSTITUTE, Valparaiso, Ind.—R, TC, S, B, A, LMC, E, RE  
 ELECTRIC INSTITUTE, INC., Hinsdale, Ill.—C, TC, S, B, E, TL  
 ELECTRONIC RADIO-TELEVISION INSTITUTE, Redick Tower, Omaha, Nebr.—R, C, TC, S, B, A, LMC, E, TL, RE, SMP, F  
 FIRST NATIONAL TELEVISION & RADIO INSTITUTE, INC., 816 Locust St., Kansas City, Mo.—RO, C, TC, S, B, A, LMC, TL  
 GULF RADIO SCHOOL, 1007 Carondelet St., New Orleans, La.—R, TC, S, B, A, LMC, E, TL  
 HOLLYWOOD RADIO & TELEVISION INSTITUTE, 810 W. 6th St., Los Angeles, Calif.—C, TC, S, B, A, LMC, E, TL  
 LINCOLN ENGINEERING SCHOOL, 859 S. 37th St., Lincoln, Nebr.—C, TC, RE, ORC  
 MASSACHUSETTS RADIO SCHOOL, 18 Boylston St., Boston, Mass.—R, TC, S, B, A, LMC, E, TL, ORC  
 MASSACHUSETTS TELEVISION INSTITUTE, INC., 568 Commonwealth Ave., Boston, Mass.—R, C, TC, S, B, E, TL, RE, ORC  
 MIDLAND RADIO & TELEVISION SCHOOLS, INC., Power & Light Bldg., Kansas City, Mo.—R, C, TC, S, B, A, LMC, E, TL, RE  
 MILWAUKEE SCHOOL OF ENGINEERING, 1020 North Broadway, Milwaukee, Wis.—R, TC, S, B, A, RE  
 NATIONAL RADIO INSTITUTE, Washington, D. C.—C, TC, S, B, A, LMC, E, TL, RE, SO, ORC  
 NATIONAL SCHOOLS, 4000 S. Figueroa St., Los Angeles, Calif.—R, C, TC, S, B, A, LMC, TL  
 NEW YORK Y.M.C.A. SCHOOLS, 5 W. 63rd St., New York, N. Y.—R, TC, S, B, E, TL, ORC  
 NILSON RADIO SCHOOL, 51 E. 42nd St., New York, N. Y.—C, TC, B, A, LMC  
 NORTHERN INSTITUTE OF TECHNOLOGY, LTD., (or, RADIO COLLEGE OF CANADA), 54 Bloor St. W., Toronto, Ont., Can.—R, C, TC, S, B, A, LMC, E, TL, RE, MR  
 NORTHWESTERN TELEVISION INSTITUTE, INC., 529 S. 7th St., Minneapolis, Minn.—R, C, TC, S, A, LMC, E, TL, RE  
 PACIFIC RADIO SCHOOL, 735 Larkin St., San Francisco, Calif.—R, C, TC, S, B, A, LMC, TL



# THE FINEST RADIO BOOK WE EVER OFFERED

You receive Valuable subscription to **RADIO-CRAFT**  
PLUS A FREE COPY of 1940 Radio-Television Reference Annual

WITH our compliments, we want to send a copy of the 1940 RADIO-TELEVISION REFERENCE ANNUAL to you FREE, if you will simply take advantage of RADIO-CRAFT magazine's special subscription offer NOW. This offer is being made for a limited time only.

The 1940 RADIO-TELEVISION REFERENCE ANNUAL has 68 pages, large size 8 1/2 x 11 1/2, with over 170 illustrations. The contents of this book has never appeared before in handy book form. Its pages cover practically every branch of radio sound, public address, servicing, television, construction articles for advanced radio men and technicians, time and money-saving kinks, wrinkles, useful circuit information, "ham" transmitters and receivers, and a host of other data.

The Annuals have always been regarded as a standard reference work for every practical branch of radio operation and service. This 1940 edition ably sustains this reputation. Every radio man wants a copy of this valuable book. Just as this book will be of unquestionable value to you, so, too, will every monthly issue of RADIO-CRAFT. This magazine brings you big value every month. It keeps you intelligently informed about new developments in radio and television. You want the news, want it fully but concisely, want it first—that is why you should read RADIO-CRAFT regularly.

This very special offer is made for just one purpose—we want you as a regular subscriber. The Annual, whose contents appears at the right, is not sold, but a copy is FREE to you if you subscribe now.

**SAME SIZE AS  
RADIO-CRAFT**

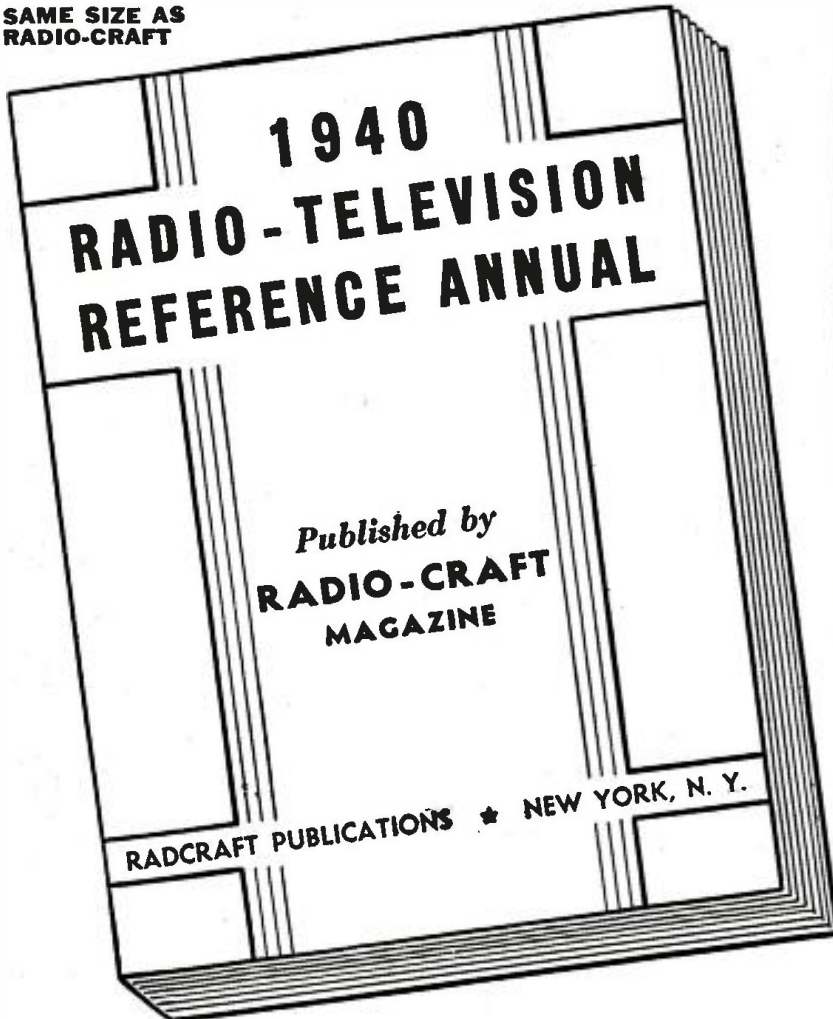

**THIS COUPON BRINGS YOU THE ANNUAL**

RADIO-CRAFT • 20 VESEY STREET • NEW YORK, N. Y.

Gentlemen: Enclosed you will find One Dollar for which enter my subscription to RADIO-CRAFT Magazine for Eight Months. Send me ABSOLUTELY FREE and POSTPAID, my copy of 1940 RADIO-TELEVISION REFERENCE ANNUAL.

This is a new order  Extend My Present Subscription

NAME ..... ADDRESS .....

CITY ..... STATE .....

DON'T DELAY — MAIL TODAY! RC-141

RADIO-CRAFT for JANUARY, 1941

Read the summary of contents  
in this FREE BOOK!

THE 1940 RADIO-TELEVISION REFERENCE ANNUAL contains a collection of the best and most important articles. Covering as they do nearly every branch of radio, they form a handy reference works. In addition, many time and labor-saving kinks, circuits and wrinkles, tried and tested by practicing Servicemen, experimenters and radio fans have been included. This book cannot be bought anywhere at any price. Yet it is yours by merely subscribing. Use the convenient coupon below.

#### BEGINNER'S SIMPLE INEXPENSIVE CONSTRUCTION ARTICLES

Beginner's Breadboard Special - a 1-Tube High-Gain All-Wave Receiver—Wiring Pointers for Radio Beginners—A Watch Charm Size 1-Tube Set—Beginner's Simple Volt-Milliammeter—Making a 1-Tube Broadcast Loop Receiver—A.C.-D.C. Power Supply for Battery Portables—A 1-Tube Short-Waver with Band Coil Switching.

#### MORE ADVANCED SET CONSTRUCTION

The "High-Sea 4" Broadcast Lamp Radio—How to Build a 6-Tube 1.4-Volt Short-Wave Superhet for the "Ham" or Short-Wave Fan—Build the "Launch Box 5" Super Set - a Broadcast Battery Portable—How to Build a Plug-Together 8 Tube Broadcast Set—The "5-In-4" All-Wave Radio for A.C. Operation—An Easily-Built 3-Tube Midset Broadcast Superheterodyne Receiver.

#### THE SERVICEMEN'S SECTION

Bass Tone Control—Simplified Variable Selectivity—Practical Servicing Pointers—Servicing Universal A.C.-D.C. Receivers—Killing the "Intermittent" Bug—A Service Shop A.C. to D.C. Power Supply—Sideline Money for Servicemen—Adding A.V.C. to any Screen-Grid T.R.F. Receiver—Iron Particles in Speaker Air Gap.

#### TEST INSTRUMENTS

A Useful Neon Lamp Tester—An Inexpensive Output Meter—Making Milliammeter Multipliers—Home-Made Frequency Modulator—The Busy Servicemen's V.T. Volt-Meter.

#### PUBLIC ADDRESS AND AMPLIFIERS

Build this Combination A.C.-D.C. Radio and Inter-Communicator—Speaker Placement in P.A. Work—The Design and Construction of an Inexpensive All-Push-Pull 10-Watt Amplifier—Obscure Sources of Hum in High-Gain Amplifiers—How to Build a High-Fidelity 5-Watt Versatile Amplifier.

#### "HAM" SECTION

Ultra-High Frequency Antennas—The Beginner's Low-Cost Xmitter—Modulator Meter—Phone Monitor—The Beginner's "Ham" Receiver—2 1/2 Meter Acorn Transceiver.

#### TELEVISION

How to Build a 441 Line T.R.F. Television Receiver—Useful Notes on Television Antennas.

#### MISCELLANEOUS

Simple Photo-Cell Relay Set Up—Making a Burglar Alarm—How to Build A.C.-D.C. Capacity Relay—How to Make a Modern Radio Treasure Locator.

#### USEFUL KINKS, CIRCUITS AND WRINKLES

Making a Flexible Coupler—Two-Timing Chime—A Simple Portable Aerial—An Improvised Non-Slip Screw-Driver. NOTE: The book contains numerous other useful Kinks, Circuits and Wrinkles, not listed here.

(approximately)

**45 ARTICLES**

(approximately)

**170 ILLUSTRATIONS**

**68 BIG PAGES**

**RADIO-CRAFT**  
20 VESEY STREET  
NEW YORK, N. Y.

# • CLASSIFIED RADIO DIRECTORY •

PORT ARTHUR COLLEGE, Port Arthur, Tex.—R, TC, B, A, LMC, E, TL, RE, ORC  
 RADIO COLLEGE OF CANADA, 54 Bloor St. W., Toronto, Ont., Can.—See NORTHERN INSTITUTE OF TECHNOLOGY, LTD.  
 RADIO INSTITUTE OF CALIFORNIA, Radio Institute Bldg., 1117 Venice Blvd., Los Angeles, Calif.—R, TC, S, B, A, LMC, E, TL, RE, BRE, ORC  
 RADIO-TELEVISION INSTITUTE, INC., 480 Lexington Ave., New York, N. Y.—R, TC, S, B, E, TL  
**RADIO TRAINING ASSOC. OF AMERICA**, 1559-61 Devon Ave., Chicago, Ill.—C, TC, S, A, LMC, E, TL, RE  
**RCA INSTITUTES**, 75 Varick St., New York, N. Y.—R, TC, S, B, A, LMC, E, TL, ORC  
**SPRAYBERRY ACADEMY OF RADIO**, 2548 University Place N.W., Washington, D. C.—C, TC, S, B, A, LMC, E, TL  
**TRI-STATE COLLEGE**, 5116 College Ave., Angola, Ind.—R, TC, E, TL, RE  
**UNIVERSAL RADIO-TELEVISION INSTITUTE**, 2549 Farnam St., Omaha, Nebr.—R, C, TC, S, B, A, LMC, E, TL, RE  
**UNIVERSAL TELEVISION SYSTEM**, 2107 Grand Ave., Kansas City, Mo.—R, C, TC, S, B, A, LMC, E, TL, RE, FM

**HARRISON RADIO CO.**, 12 W. Broadway, New York, N. Y.—BT, TV, T  
**HOWARD RADIO CO.**, 1735 Belmont Ave., Chicago, Ill.—SM  
**HYGRADE SYLVANIA CORP.**, 500 5th Ave., New York, N. Y.—T  
**E. F. JOHNSON CO.**, Waseca, Minn.—AT, BT  
**LAFAYETTE RADIO CORP.**, 100 6th Ave., New York, N. Y.—A, AT, E, F, FM, IE, SM, SS, TV, T  
**MACMILLAN COMPANY**, 60 5th Ave., New York, N. Y.—A, E  
**MCGRAW-HILL BOOK CO.**, 330 W. 42nd St., New York, N. Y.—AT, BT, E, S  
**P. R. MALLORY & CO., INC.**, 3029 E. Washington St., Indianapolis, Ind.—SM  
**MEISSNER MFG. CO.**, 7th & Belmont Sts., Mt. Carmel, Ill.—BT  
**MIDLAND TELEVISION, INC.**, Power & Light Bldg., Kansas City, Mo.—A, AT, BT, E, IE, SM, SS, TT  
**MONTGOMERY WARD & CO.**, 619 W. Chicago Ave., Chicago, Ill.—A, AT, BT, E, IE, S, SS, TV, T  
**\*MOTOROLA—Galvin Mfg. Corp.**  
**NATIONAL CO., INC.**, 61 Sherman St., Malden, Mass.—SM  
**PHILCO RADIO & TELEVISION CORP.**, Phila., Pa.—S, M

Frequency meters . . . FM  
 High-voltage test leads . . . HV  
 Impedance bridges . . . IB  
 Instrument fuses . . . F  
 Inductance-Capacity checkers . . . LCC  
 Meters . . . M  
 Multimeters . . . MM  
 Neon indicators . . . NI  
 Ohmmeters . . . OHM  
 Osc. frequency modulators . . . MOD  
 Output indicators . . . OI  
 Output recorders . . . OR  
 Resistance bridges . . . RB  
 Set analyzers . . . SA  
 Signal analyzers . . . SGA  
 Signal generators . . . SG  
 Signal tracers . . . ST  
 Speaker testers . . . SPK  
 Stage analyzers . . . S  
 Tube testers . . . TT  
 Tuning wands . . . TW  
 Vacuum-tube voltmeters . . . VTV  
 Vibrator testers . . . VT

## SERVICE MANUALS, BOOKS & MAGAZINES



Acoustics . . . . .	A
Advanced theory . . . . .	AT
Beginners' theory . . . . .	BT
Catalog (special) . . . . .	C
Electronics . . . . .	E
Facsimile . . . . .	F
Frequency Modulation . . . . .	FM
Interference elimination . . . . .	IE
Magazines . . . . .	M
Manual on bridges (L-C Checker) . . . . .	MB
Photoelectric cells . . . . .	PEC
Quartz crystal control . . . . .	QCC
Service manuals . . . . .	SM
Servicing . . . . .	S
Sound pictures . . . . .	SP
Sound systems . . . . .	SS
Television . . . . .	TV
Tubes . . . . .	T
Year books . . . . .	YB

**AEROVOX CORPORATION**, 740 Belleville Ave., New Bedford, Mass.—IE, MB  
**AKRAD PRODUCTS CO.**, 362 Wooster Ave., Akron, Ohio—BT, SM  
**ALLIED RADIO CORP.**, 833 W. Jackson Blvd., Chicago, Ill.—A, AT, BT, E, F, FM, IE, SM, SS, TV, T  
**AMERICAN RADIO RELAY LEAGUE**, 38 La Salle Rd., Hartford, Conn.—AT, BT, IE, T, M ("OST")  
**AMERICAN TECHNICAL SOCIETY**, Drexel Ave. at 58th St., Chicago, Ill.—A, BT  
**\*ARRL—American Radio Relay League**  
**THEO. AUDEL & CO.**, 49 W. 23rd St., New York, N. Y.—A, AT, SP, SS, TV, T  
**AUDIOGRAPH SOUND SYSTEMS**, 1313 W. Randolph St., Chicago, Ill.—SS  
**BLAKISTON COMPANY**, 1012 Walnut St., Phila., Pa.—A  
**BLILEY ELECTRIC CO.**, Union Station Bldg., Erie, Pa.—QCC  
**CALDWELL-CLEMENTS, INC.**, 480 Lexington Ave., New York, N. Y.—YB, M ("Radio Today," "Radio Year Book")  
**CAMERON PUBLISHING CO.**, P.O. Box 1386, Little River, Miami, Fla.—A, AT, BT, SM, SP, SS, TV  
**CLAROSTAT MFG. CO., INC.**, 285 N. 6th St., Brooklyn, N. Y.—SM  
**CRUMPACKER DISTRIBUTING CORP.**, 1801 Fannin St., Houston, Texas—IE, SM  
**TOBE DEUTSCHMANN CORP.**, Canton, Mass.—IE  
**FREDERICK J. DRAKE & CO.**, 179 N. Michigan Ave., Chicago, Ill.—E, SM  
**HUGH H. EBY, INC.**, 4700 Stenton Ave., Phila., Pa.—PEC  
**FINCH TELECOMMUNICATIONS, INC.**, 1819 Broadway, New York, N. Y. (Plant—Passaic, N. J.)—F  
**FISCHER DISTRIBUTING CORP.**, 222 Fulton St., New York, N. Y.—AT, E, FM, IE, SM, SS, TV, T  
**GALVIN MFG. CORP.**, 4545 Augusta Blvd., Chicago, Ill.—"Motorola"—SM  
**GENERAL ELECTRIC CO.**, Schenectady, N. Y., & Bridgeport, Conn.—FM, SM, TV

**RADCRAFT PUBLICATIONS, INC.**, 20 Vesey St., New York, N. Y., \*RADIO-CRAFT,—AT, BT, S, SM, M ("RADIO-CRAFT")  
**\*RADIO-CRAFT—Radcraft Publications, Inc.**  
**RADIO ELECTRIC SERVICE CO., INC.**, N.W. Cor. 7th & Arch Sts., Phila., Pa.—A, AT, BT, E, F, FM, IE, SM, SS, TV, T  
**RADIO, LTD.**, 1300 Kenwood Rd., Santa Barbara, Calif.—AT, BT, IE, T, M ("RADIO")  
**RADIO & TECHNICAL PUB. CO.**, 45 Astor Place, New York, N. Y.—A, AT, BT, IE, SM, SS, T, S  
**\*RADIO TODAY—Caldwell-Clements, Inc.**  
**RADIO TRAINING ASSN. OF AMERICA**, 4525 Ravenswood Ave., Chicago, Ill.—AT, B, E, SM, T  
**RADOLEK COMPANY**, 601 W. Randolph St., Chicago, Ill., \*"Radolek"—A, AT, BT, E, F, FM, IE, S, SS, TV, T  
**RCA MFG. CO.**, Front & Cooper St., Camden, N. J., \*"RCA"—A, AT, BT, E, F, FM, SM, SS, TV, T  
**JOHN F. RIDER, PUBLISHER**, 404 4th Ave., New York, N. Y.—AT, E, SM, TV, T, BT, M, FM, S  
**MAURICE SCHWARTZ & SON**, 710-712 Broadway, Schenectady, N. Y.—A, AT, BT, F, FM, IE, SM, SS, TV, T, E  
**SENTINEL RADIO CORP.**, 2020 Ridge Ave., Evanston, Ill.—SM  
**SHERWOOD PRESS**, Box 552, Edgewater Branch, Cleveland, Ohio—A, IE, SM  
**S. O. S. CINEMA SUPPLY CORP.**, 636 11th Ave., New York, N. Y.—A, E, SS  
**SPRAGUE PRODUCTS CO.**, N. Adams, Mass.—IE  
**SUN RADIO CO.**, 212 Fulton St., New York, N. Y.—A, AT, BT, E, FM, IE, SM, SS, TV, T  
**SUPREME PUBLICATIONS**, 3727 W. 13th St., Chicago, Ill.—AT, BT, SM, S  
**THORDARSON ELECTRIC MFG. CO.**, 500 W. Huron St., Chicago, Ill.—BT, S, SS  
**UNITED CATALOG PUBLISHERS, INC.**, 230 5th Ave., New York, N. Y.—C  
**UNIVERSAL TELEVISION SYSTEM**, 2107 Grand Ave., Kansas City, Mo.—AT, BT, E, SS, TV, T  
**D. VAN NOSTRAND CO., INC.**, 250 4th Ave., New York, N. Y.—A, E, S, T  
**JOHN WILEY & SONS, INC.**, 440 4th Ave., New York, N. Y.—A, AT, E, S, SS, TV

**AEROVOX CORPORATION**, 740 Belleville Ave., New Bedford, Mass., \*"L-C Checker"—CT, SA, RB, LCC, VTV  
**AIRPLANE & MARINE DIRECTION FINDER CORP.**, Clearfield, Pa.—FM  
**ALDEN PRODUCTS CO.**, 715 Center St., Brockton, Mass.—AD  
**ALLIED RADIO CORP.**, 833 W. Jackson Blvd., Chicago, Ill.—AO, AD, CRO, CT, CC, DB, FA, FM, IB, F, M, MM, NI, MOD, OHM, OI, RB, SA, SG, SPK, SGA  
**AMERICAN COMMUNICATIONS CORP.**, 123 Liberty St., New York, N. Y.—AO  
**AMERICAN PHENOLIC CORP.**, 1250 Van Buren St., Chicago, Ill.—"Amphenol"—AD  
**AMERICAN RADIO HARDWARE CO.**, 476 Broadway, New York, N. Y., \*"Arhco"—AD, TW  
**\*AMPHENOL—AMERICAN PHENOLIC CORP.**  
**AMPLIFIER CO. OF AMERICA**, 17 W. 20th St., New York, N. Y.—AO, DB, OI  
**\*ANALYST—Meissner Mfg. Co.**  
**VICTOR J. ANDREW**, 6429 S. Laverne Ave., Chicago, Ill.—SG  
**APPROVED TECHNICAL APPARATUS CO.**, 123 Liberty St., New York, N. Y.—CT, MM, OHM, SA, SG, TT, M, OI, SGA, SPK, S  
**\*ARHCO—American Radio Hardware Co.**  
**ASSOCIATED RESEARCH, INC.**, 16 N. May St., Chicago, Ill.—CT, DB, FM, IB, M, MM, NI, OHM, RB, SA, SPK, TT, VTV, VT  
**\*AUDIOGRAPH—John Meck Industries**  
**\*AUDOLYZER—Supreme Instruments Corp.**  
**BARKER & WILLIAMSON**, Ardmore, Pa.—AO, FM  
**BROWNING LABORATORIES, INC.**, 750 Main St., Winchester, Mass.—FM, SG  
**BUD RADIO, INC.**, 5250 Cedar Ave., Cleveland, Ohio, \*"Bud"—AD  
**WM. W. L. BURNETT RADIO LAB.**, 4814 Idaho St., San Diego, Calif.—CC, FM  
**BURTON-ROGERS CO.**, 857 Boylston St., Boston, Mass., \*"Hoyt," "Burton-Rogers"—M  
**CARRON MFG. CO.**, 415 S. Aberdeen St., Chicago, Ill.—AO, AD, SGA, SG, TW, S  
**\*CHANALYST—RCA Mfg. Co.**

**CLAROSTAT MFG. CO., INC.**, 285 N. 6th St., Brooklyn, N. Y.—DB  
**CLOUGH-BRENGLE CO.**, 5501 N. Broadway, Chicago, Ill., \*"Clough-Brengle"—AO, CRO, CT, MM, MOD, OHM, RB, SA, SG, SPK, TT, DB, IB, M, OI  
**CONSOLIDATED WIRE & ASSOC. CORP.**, Peoria & Harrison Sts., Chicago, Ill.—CT, OI, RB, TT  
**CORNELL-DUBILIER ELEC. CORP.**, 1000 Hamilton Blvd., S. Plainfield, N. J.—CT  
**CRUMPACKER DISTRIB. CORP.**, 1801 Fannin St., Houston, Texas—AO, AD, CRO, CT, M, MM, NI, OHM, OI, SA, SGA, SG, SPK, TT, VTV, S  
**DAVEN COMPANY**, 158 Summit St., Newark, N. J.—DB, IB, OI, RB  
**DAYCO RADIO CORP.**, 915 Valley St., Dayton, Ohio—CRO, MM, OHM, SA, TT  
**DAYTON ACME CO.**, 2339 Gilbert Ave., Cincinnati, Ohio—AO, CRO, MOD, SA, SG, ST, TT, VTV, SGA, S  
**\*DEPENDABLE—Radio City Products Co., Inc.**  
**\*DETERMOMM—Ohmite Mfg. Co.**  
**TOBE DEUTSCHMANN CORP.**, Canton, Mass.—CT, IB, RB  
**DOOLITTLE & FALKNER, INC.**, 7421 Loomis Blvd., Chicago, Ill.—FM  
**ALLEN B. DU MONT LABS., INC.**, Passaic, N. J.—CRO  
**\*DYNALYZER—Radio Instrument Mfg. Co.**  
**THE ESTERLINE-ANGUS CO., INC.**, Box 596, Indianapolis, Ind.—OR  
**\*EXAM-ETER—Solar Mfg. Corp.**

## SERVICING EQUIPMENT



Adapters . . . . .	AD
Audio oscillators . . . . .	AO
Cabinet touch-up kit . . . . .	CU
Cathode-ray oscilloscopes . . . . .	CRO
Condenser testers . . . . .	CT
Contact cleaner . . . . .	CF
Crystal calibrators . . . . .	CC
Decade boxes (resistance) . . . . .	DB
Dial oil . . . . .	DO
Dummy antenna . . . . .	DA
Electrostatic voltmeter . . . . .	EV
Frequency analyzers . . . . .	FA



# CLASSIFIED RADIO DIRECTORY

## SOUND SYSTEMS, AMPLIFIERS & ACCESSORIES



Acoustic materials . . . AM  
 Amplified chimes . . . AC  
 Amplifier foundation units AFU  
 Baffles . . . B  
 Carrying cases . . . C  
 Hearing-aids . . . HA  
 Hearing-aid components HAC  
 Kits (amplifier) . . . K  
 Mobile amplifiers . . . M  
 Power amplifiers . . . PA  
 Preamplifiers . . . PRE  
 Recorders and recording equipment (see Recording Equipment)  
 Remote controllers . . . RC  
 School sound systems . . . SSS  
 Sound motion picture amplifiers . . . SPA  
 Sound systems (complete) . . . SS  
 Special . . . S

\*EXCEL—Hickok Electrical Instrument Co.  
 FERRANTI ELECTRIC, INC., 30 Rockefeller Plaza, New York, N. Y., \*Ferranti—EV  
 FERRIS INSTRUMENT CORP., Boonton Ave., Boonton, N. J., \*Ferris—CC, SG  
 FISCHER DISTRIBUTING CORP., 222 Fulton St., New York, N. Y.—AD, AO, CRO, CT, CC, DB, FM, IB, F, M, MM, NI, MOD, OHM, OI, RB, SA, SG, SPK, TT, TW, VTV, S, FA, SGA  
 GENERAL CEMENT MFG. CO., 1041 Kilburn Ave., Rockford, Ill.—CU, DO  
 GENERAL ELECTRIC CO., Schenectady, N. Y. & Bridgeport, Conn.—CRO, DB, FA, FM, IB, M, MM, MOD, RB, SA, SGA, SPK, TT, VTV  
 THOMAS B. GIBBS & CO., 900 W. Lake St., Chicago, Ill.—AO, CC  
 HARRISON RADIO CO., 12 W. Broadway, New York, N. Y.—AD, AO, CRO, CT, CC, DB, FM, FA, IB, F, M, MM, NI, MOD, OHM, OI, RB, SA, SGA, SG, ST, TT, TW, VTV, S  
 HEWLETT-PACKARD CO., 367 Madison Ave., Palo Alto, Calif.—AO, FA, FM, RB, VTV  
 HICKOK ELECTRICAL INSTRUMENT CO., 10514 Dupont Ave., Cleveland, Ohio, \*Excel—Hickok—CRO, CT, CC, DB, FA, FM, IB, M, MM, MOD, OHM, OI, RB, SA, SGA, SPK, TT, VTV, ST  
 HERBERT H. HORN, 1201 S. Olive St., Los Angeles, Calif.—TT, TW, VTV, S  
 \*HOYT—Burton-Rogers Co.  
 \*ICA—Insuline Corp. of America  
 INDUSTRIAL INSTRUMENTS, INC., 156 Culver Ave., Jersey City, N. J.—AO, CT, IB, RB, VTV  
 INSULINE CORP. OF AMERICA, 30-30 Northern Blvd., Long Island City, N. Y., \*ICA—AD, AO, M, TW, VTV, VT  
 JACKSON ELECTRICAL INSTRUMENT CO., 129 Wayne Ave., Dayton, Ohio, \*Jackson—CRO, CT, MM, MOD, OHM, SA, SG, TT, VTV, AO  
 JONES-ORME CO., 2233 University Ave., St. Paul, Minn.—AO, CRO, SG  
**LAFAYETTE RADIO CORP.**, 100 6th Ave., New York, N. Y.—AO, AD, CRO, CT, CC, DB, FA, FM, IB, M, MM, NI, MOD, OHM, OI, RB, SA, SG, SGA, SPK, TT, TW, VTV, S, F  
 LAMPKIN LABORATORIES, Bradenton, Fla.—FM  
 LAUREHK RADIO MFG. CO., 3918 Monroe Ave., Wayne, Mich.—AO  
 \*L-C-CHECKER—Aerovox Corp.  
 LEOTONE RADIO CO., 63 Dey St., New York, N. Y.—APK  
 LITTELFUSE, INC., 4757 Ravenswood Ave., Chicago, Ill.—F, NI  
 M & H SPORTING GOODS CO., 512 Market St., Phila., Pa.—TT, TW, VTV, S  
 MARINE RADIO CORP., 117-19—168th St., Jamaica, N. Y.—CRO  
 MARION ELECTRICAL INSTRUMENT CO., Manchester, N. H., \*Marion—M  
**JOHN MECK INDUSTRIES**, 1313 W. Randolph St., Chicago, Ill., \*Meck, \*Audio-graph—AO, OHM, OI, RB, SA, SG, SPK, VT  
**MEISSNER MFG. CO.**, 7th & Belmont, Mt. Carmel, Ill.—CC, C, SGA  
 MILLION RADIO & TELEVISION LABS., 685 W. Ohio St., Chicago, Ill., \*Million—AD, AO, MM, OHM, OI, SA, SG, ST, TT, VTV  
 MONARCH MFG. CO., 3341 Belmont Ave., Chicago, Ill., \*Monarch—SG  
**MONTGOMERY WARD & CO.**, 619 W. Chicago Ave., Chicago, Ill.—AO, AD, CRO, CT, CC, FM, IB, F, M, MM, OHM, OI, RB, SA, SGA, SG, TT, VTV, C  
 J. L. D. MORRISON CO., 1816 Wisconsin Ave., Washington, D. C.—SGA, C  
 MUTER COMPANY, 1255 S. Michigan Ave., Chicago, Ill., \*Muter—RB  
 TED NAGLE EQUIPMENT CORP., General Motors Bldg., Detroit, Mich.—CRO  
**OHMITE MFG. CO.**, 4825 W. Fluorony St., Chicago, Ill., \*Determohm—DB, DA  
 PHILCO RADIO & TELEVISION CORP., Tioga & C Sts., Phila., Pa.—AO, SG, TT, AD, CRO, CT, OHM, SA, VTV  
 PIERSON-DeLANE, INC., 2345-47 W. Washington Blvd., Los Angeles, Calif.—FM  
 POTTER COMPANY, 1950 Sheridan Rd., North Chicago, Ill.—CT  
 PRECEPTOR ELECTRICAL EQUIPMENT, 301 Hubbard Bldg., Pontiac, Mich., \*Preceptor—TT  
 PRECISION APPARATUS CO., 647 Kent Ave., Brooklyn, N. Y., \*Precision—MM, OHM, SA, SG, TT, SGA, SPK  
 RADER CORPORATION, 1733 Milwaukee Ave., Chicago, Ill.—SGA  
 THE RADIART CORPORATION, 13229 Shaw Ave., E. Cleveland, Ohio—VT  
**RADIO CITY PRODUCTS CO., INC.**, 88 Park Pl., New York, N. Y., \*Dependable—AD, AO, CRO, CT, MM, OHM, OI, RB, SA, SG, ST, TT, VTV  
 RADIO DESIGN CO., 1353 Sterling Pl., Brooklyn, N. Y., \*Radio Design—MM, OHM, OI, SA, TT  
 RADIO ELECTRIC SERVICE CO., INC., N. W. Cor. 7th & Arch Sts., Phila., Pa.—AO, A, CRO, CT, CC, DB, FA, FM, IB, F, M, MM, NI, MOD, OHM, OI, RB, SA, SGA, SG, SPK, TT, TW, VTV, C

RADIO ENGINEERING LABS., INC., 35-54 36th St., Long Island City, N. Y.—FM, SG  
 RADIO INSTRUMENTS MFG. CO., 1131 Terry Rd., Jackson, Miss., \*Rimco—FM, MM, OHM, SP, VTV  
 RADIOTECHNIC LABORATORY, 1328 Sherman Ave., Evanston, Ill., \*R-T-L—OHM, TT, VTV  
 \*R-T-L—Radiotechnic Laboratory  
**RADOLEK COMPANY**, 601 W. Randolph St., Chicago, Ill.—AO, AD, CRO, CT, CC, DB, FA, FM, IB, F, M, MM, NI, MOD, OHM, OI, RB, SA, SGA, SG, SPK, TT, TW, VTV, C  
**\*RANGER EXAMINER**—Readrite Meter Works  
**RCA MFG. CO., INC.**, Front & Cooper Sts., Camden, N. J., \*RCA—AO, AD, CRO, CT, CC, FA, FM, IB, MOD, OHM, OI, SA, SGA, SG, SPK, TT, TW, VTV, C  
**READRITE METER WORKS**, 136 E. College Ave., Bluffton, Ohio, \*Ranger-Examiner, \*Readrite—AD, M, MM, OHM, SA, SG, TT  
**\*RIMCO**—Radio Instrument Mfg. Co.  
 ROTO-RANGER—Simpson Electric Co.  
 WALTER L. SCHOTT CO., 5264 W. Pico Blvd., Los Angeles, Calif., \*Walsco—CU, DO, CF  
 MAURICE SCHWARTZ & SON, 710-712 Broadway, Schenectady, N. Y.—AD, AO, CRO, CT, CC, DB, FA, FM, IB, F, M, MM, NI, MOD, OHM, OI, RB, SA, SG, SGA, SPK, TT, TW, VTV, C  
 SHALLCROSS MFG. CO., 10 Jackson Ave., Collingdale, Pa., \*Shallcross—DB, RB  
 \*SIGNALIZER—Million Radio & Telev. Labs.  
**\*SIGNALYST**—RCA Mfg. Co.  
 SIMPSON ELECTRIC CO., 5216 W. Kinzie St., Chicago, Ill., \*Simpson, \*Roto-Ranger—M, MM, OHM, SA, SG, TT  
**SOLAR MFG. CORP.**, Bayonne, N. J., \*Solar—CT  
 S.O.S. CINEMA SUPPLY CORP., 636 11th Ave., New York, N. Y.—FM  
 SPRAGUE PRODUCTS CO., N. Adams, Mass., \*Tel-Ohmike—CT  
 STANDARD ELECTRICAL PRODUCTS CO., 317 Sibley St., St. Paul, Minn.—AO  
 STANDARD TECHNICAL DEVICES, INC., 3008 Ave. M, Brooklyn, N. Y.—HV  
 STARK ELECTRICAL INSTRUMENT CO., 161A King St. W., Toronto, Ont., Can.—AD, CT, FA, MM, NI, OHM, RB, SA, TT, VTV  
 SUN RADIO CO., 212 Fulton St., New York, N. Y.—AO, AD, CRO, CT, DB, FA, FM, IB, F, M, MM, NI, MOD, OHM, OI, RB, SA, SG, SGA, SPK, TT, VTV, C  
 SUNDT ENGINEERING CO., 4757 Ravenswood Ave., Chicago, Ill.—NI  
**SUPERIOR INSTRUMENTS CO.**, 136 Liberty St., New York, N. Y.—CT, M, MM, OHM, SA, SG, TT, SGA, VTV, C  
**SUPREME INSTRUMENTS CORP.**, 414 Howard St., Greenwood, Miss., \*Supreme—AD, AO, CRO, CT, M, MM, MOD, OHM, SA, SG, TT, VTV, SGA  
 \*TACO—Technical Appliance Corp.  
 TECHNICAL APPLIANCE CORP., 17 E. 16th St., New York, N. Y., \*Taco—OI  
 TECHNICAL PRODUCTS INTERNATIONAL, 135 Liberty St., New York, N. Y.—M  
 TEFFT RADIO CO., Plymouth, Mich.—AO, CT, FM, LA, MOD, SA, SG, TT  
 TELEVICO COMPANY, 341 N. Pulaski Rd., Chicago, Ill.—AO, CC, DB, SG, VTV  
 TELEVISIO PRODUCTS, INC., 1135 N. Cicero Ave., Chicago, Ill.—AO, CC, FM, SG, VTV  
 TELEX PRODUCTS CO., Minneapolis, Minn.—AO, CRO  
 \*TELO-MIKE—Sprague Products Co.  
 THORDARSON ELECTRIC MFG. CO., 500 W. Huron St., Chicago, Ill.—CRO  
 \*TRACEOMETER—Hickok Electrical Instrument Co.  
 TRANSFORMER CORP. OF AMERICA, 69 Wooster St., New York, N. Y.—AO  
**TRIPLETT ELECTRICAL INSTRUMENT CORP.**, 122 Main St., Bluffton, Ohio, \*Triplet—AD, CT, FA, M, MM, OHM, OI, SA, SG, TT, VTV, VT  
 TRIUMPH MFG. CO., 4017 W. Lake St., Chicago, Ill., \*Triumph—AD, AO, CRO, CT, IB, MM, MOC, OHM, OL, RB, SA, SG, TT, VTV, VT  
**\*VEDOLYZER**—Supreme Instrument Corp.  
 \*WALSCO—Walter L. Schott Co.  
 EARL WEBBER CO., 1313 W. Randolph St., Chicago, Ill., \*Webber—CRO, MM, OHM, SA, SG, SPK, TT, NI, SGA  
 WESTERN ELECTRIC CO., 300 Central Ave., Kearny, N. J.—CRO  
 WESTINGHOUSE ELECTRIC & MFG. CO., Orange St., Newark, N. J.—M, MM  
 WESTON ELECTRICAL INSTRUMENT CORP., 614 Frelinghuysen Ave., Newark, N. J., \*Weston—CT, M, MM, OHM, OI, SA, SG, TT, VTV, FM  
 WHEELCO INSTRUMENTS CO., 1933 S. Halsted St., Chicago, Ill.—M  
 WILCOX ELECTRIC CO., INC., 4014 State Line, Kansas City, Kans.—FM

\*ACA—Amplifier Co. of America  
 ACOUSTIC EQUIPMENT CO., 323 Walton Bldg., Atlanta, Ga.—SS (sell and rent)  
**\*AIRLINE**—Montgomery Ward & Co.  
 AIRPLANE & MARINE DIRECTION FINDER CORP., Clearfield, Pa.—PA, PRE, SS  
 ALLIED BURNS CO., 1008 Madison Ave., Toledo, Ohio—SS  
**ALLIED RADIO CORP.**, 833 W. Jackson Blvd., Chicago, Ill., \*Knight—C, K, PA, PRE, SS  
 AMERICAN COMMUNICATIONS CORP., 123 Liberty St., New York, N. Y.—AM, SS  
 AMERICAN TELEVISION CORP., 130 W. 56th St., New York, N. Y.—SS  
**AMPERITE COMPANY**, 561 Broadway, New York, N. Y., \*Amperite—PRE  
**AMPLIFIER CO. OF AMERICA**, 17 W. 20th St., New York, N. Y., \*ACA—K, PA, PRE, RC, SS  
 AMPLITONE PRODUCTS CO., 135 Liberty St., New York, N. Y.—C, K, M, PA, PRE, RC, SS  
 ATLAS SOUND CORP., 1451 39th St., Brooklyn, N. Y., \*Atlas—AM  
 AUDIO DEVELOPMENT CO., 123 Bryant Ave., N., Minneapolis, Minn.—PA, PRE, SS, SSS  
**AUDIOGRAPH SOUND SYSTEMS**, 1313 W. Randolph St., Chicago, Ill.—C, PA, PRE, SS  
 BANK'S MANUFACTURING CO., 5019 N. Winthrop Ave., Chicago, Ill.—PA, PRE, SS  
 BARKER & WILLIAMSON, Ardmore, Pa.—PA, PRE  
 \*BELFONE—Bell Sound System, Inc.  
 BELL SOUND SYSTEMS, INC., 1183 Essex Ave., Columbus, Ohio, \*Belfone—C, PA, PRE, SS  
 DAVID BOGEN CO., INC., 663 Broadway, New York, N. Y., \*Bogen—PA, PRE, SS  
 W. C. BRAUN, INC., 601 W. Randolph St., Chicago, Ill.—C, K, M, PA, PRE, RC, SS  
 BUD RADIO, INC., 5205 Cedar Ave., Cleveland, Ohio—C, K  
 CANTON TRADING CO., 135 Liberty St., New York, N. Y., \*Kantola—PA, PRE  
 CASTLEWOOD MFG. CO., 12th & Burnett Sts., Louisville, Ky.—B  
**CHICAGO SOUND SYSTEMS CO.**, 200 E. Illinois St., Chicago, Ill., \*Chicago Sound Amplifiers—AM, C, K, PA, PRE, SS  
 CINEMA ENGINEERING CO., 1508 S. Verdugo Ave., Burbank, Calif., \*Cinema—K, M, PA, PRE, SS  
 \*CLARION—Transformer Corp. of America  
 COLLINS RADIO CO., 2920 1st Ave., Cedar Rapids, Iowa—PA, PRE  
 CRACRAFT, INC., 28 Grove St., New York, N. Y.—SS  
 CRUMPACKER DISTRIB. CORP., 1801 Fannin St., Houston, Texas—PA, PRE, SS  
 DE VRY CORPORATION, 1111 Armitage Ave., Chicago, Ill.—AM, C, M, PA, PRE, SS  
 ELECTRONIC APPLICATIONS, Brunswick, Me.—PA, PRE  
 ELECTRONIC SOUND & MUSIC CO., 10 Stuyvesant St., New York, N. Y.—PA, PRE, SS  
 EMPIRE RADIO MFG., 114 E. 47th St., New York, N. Y.—SS  
 ERIE RESISTOR CORP., 644 W. 12th St., Erie, Pa.—AM  
 ERWOOD SOUND EQUIPMENT CO., 224 W. Huron St., Chicago, Ill.—C, M, PA, PRE, RC, SS  
 FERRANTI ELECTRIC, INC., 30 Rockefeller Plaza, New York, N. Y., \*Ferranti—PA, PRE

# • CLASSIFIED RADIO DIRECTORY •

FINCH TELECOMMUNICATIONS, INC., 1819 Broadway, New York, N. Y.—PA, PRE  
 FISCHER DISTRIBUTING CORP., 222 Fulton St., New York, N. Y.—AM, C, K, PA, PRE, SS  
 FOX SOUND EQUIPMENT CO., 3120 Monroe St., Toledo, Ohio—SS  
 FULTON RADIO CORP., 100 6th Ave., New York, N. Y.—"Fulton"—PA, PRE, SS  
 THE JOHN CABLE MFG. CO., 1200 W. Lake St., Chicago, Ill.—PA  
 GENERAL COMMUNICATION PRODUCTS CO., Lexington Ave. at Vine, Hollywood, Calif.—PA, PRE, SS  
 GENERAL RADIO CO., 30 State St., Cambridge, Mass.—"G-R"—S  
 THOMAS B. GIBBS & CO., 900 W. Lake St., Chicago, Ill.—"Gibbs"—PA, PRE, RC, SS  
 GLOBE PHONE MFG. CORP., Reading, Mass.—SS  
 \*G-R—General Radio Co.  
 GUARDIAN ELECTRIC MFG. CO., 1621 W. Walnut St., Chicago, Ill.—RC  
 GUIDED RADIO CORP., 118 E. 25th St., New York, N. Y.—PA, PRE, SS  
 ROBERT M. HADLEY CO., 709 E. 61st St., Los Angeles, Calif. & P. O. Box 456, Newark, Del.—"Hadley"—K  
 THE HALLDORSON COMPANY, 4500 Ravenswood Ave., Chicago, Ill.—K  
 HAMMOND MANUFACTURING CO., Guelph, Ontario, Can.—C, K  
 HARRISON RADIO CO., 12 W. Broadway, New York, N. Y.—C, K, PA, PRE, SS  
 A. G. HINTZE, 300 W. Adams St., Chicago, Ill.—AM  
 HERBERT H. HORN, 1201 S. Olive St., Los Angeles, Calif.—AM, PA, SS  
 INSULINE CORP. OF AMERICA, 30-30 Northern Blvd., L. I. City, N. Y.—C, K  
 CHARLES JACK MFG. CORP., 27 E. Philadelphia St., York, Pa.—PA, PRE, SS  
 JEFFERSON ELECTRIC CO., Bellwood, Ill.—"Jefferson"—K  
 JOHNS-MANVILLE, 22 E. 40th St., New York, N. Y.—AM  
 \*KANTOLA—CANTON TRADING CO.  
 KENYON TRANSFORMER CO., INC., 840 Barry St., New York, N. Y.—"Kenyon"—K  
 \*KNIGHT—Allied Radio Corp.  
 LAFAYETTE RADIO CORP., 100 6th Ave., New York, N. Y.—AM, C, PA, PRE, SS  
 \*LAFAYETTE—Radio Wire Television, Inc.

LAUREHK RADIO MFG. CO., 3918 Monroe Ave., Wayne, Mich.—"Laurehk"—C, PA  
 LE FEBURE CORPORATION, 716 Oakland Blvd., Cedar Rapids, Iowa—C  
 LEOTONE RADIO CO., 63 Day St., New York, N. Y.—PA, PRE, SS  
 LINCROPHONE COMPANY, 1661 Howard Ave., Utica, N. Y.—C, M, PA, SS, PRE  
 M. & H. SPORTING GOODS CO., 512 Market St., Phila., Pa.—C, K, PA, SS  
 MARINE RADIO CORP., 117-19 168th St., Jamaica, N. Y.—"Marine"—PA, PRE, SS  
 MILES REPRODUCER CO., INC., 812 Broadway, New York, N. Y.—"Miles"—AM, C, PA, PRE, K, SS  
 MILLION RADIO & TELEVISION LABS., 685 W. Ohio St., Chicago, Ill.—"Million"—C, M, PA, PRE  
 MONTGOMERY WARD & CO., 619 W. Chicago Ave., Chicago, Ill.—"Airline"—C, PA, PRE, SS, AM  
 MORLEN ELECTRIC CO., 60 W. 15th St., New York, N. Y.—"Morlen, Inc."—PA, PRE, SS  
 MUSIC MASTER MFG. CO., 508 S. Dearborn St., Chicago, Ill.—K, PA, SS  
 NASH RADIO PRODUCTS CO., 6267 Gravois Ave., St. Louis, Mo.—C  
 NATIONAL COMPANY, INC., 61 Sherman St., Maiden, Mass.—PRE  
 NATIONAL DOBRO CORP., 400 S. Peoria St., Chicago, Ill.—SS  
 NATIONAL UNION RADIO CORP., 57 State St., Newark, N. J.—M, PA, PRE, SSS, SS  
 NORWALK TRANSFORMER CORP., South Norwalk, Conn.—"Norwalk"—K, M, PA, PRE, RC, SS  
 IRVING J. OLSON, 362 Wooster Ave., Akron, Ohio—PRE, RC  
 OPERADIO MFG. CO., 13th & Indiana Sts., St. Charles, Ill.—"Operadio"—PA, PRE, SS  
 PACENT ENGINEERING CORP., 79 Madison Ave., New York, N. Y.—"Pacent"—PA, PRE, SS  
 PAR-METAL PRODUCTS CORP., 32-62 49th St., Long Island City, N. Y.—AFU  
 PHILCO RADIO & TELEVISION CORP., Tioga & C Sts., Phila., Pa.—SS, PA  
 PHONOTONE LABORATORIES, INC., S. E. 15th St., Washington, Ind.—AM, C, PA, SS  
 \*POWERIZER—Radio Receptor Co., Inc.  
 PRESTO RECORDING CORP., 242 W. 55th St., New York, N. Y.—"Presto"—PA, PRE

RACON ELECTRIC CO., INC., 52 E. 19th St., New York, N. Y.—AM  
 THE RADIOTECHNIC LABORATORY, 1328 Sherman Ave., Evanston, Ill.—PA  
 RADIO ELECTRIC SERVICE CO., INC., N. W. Cor. 7th & Arch Sts., Phila., Pa.—A, C, K, PA, PRE, SS  
 RADIO RECEPTOR CO., INC., 251 W. 19th St., New York, N. Y.—"Powerizer"—PA, PRE, SS  
 RADIO WIRE TELEVISION, INC., 100 6th Ave., New York, N. Y.—"Lafayette"—C, M, PA, RC, SS  
 RAOLEK COMPANY, 601 W. Randolph St., Chicago, Ill.—"Radolek"—PA, PRE, SS, AM, C, K  
 RANGERTONE, INC., 201 Verona Ave., Newark, N. J.—AC  
 RAULAND CORPORATION, 3333 Belmont Ave., Chicago, Ill.—"Rauland"—PA, PRE, SS  
 RAY-LAB, INC., 211 Railroad Ave., Elmira, N. Y.—"Ray-Lab"—C, M, PA, PRE, SS  
 RCA MFG. CO., Front & Cooper Sts., Camden, N. J.—"RCA"—M, PA, PRE, RC, SS, K  
 REGAL AMPLIFIER MFG. CORP., 14 W. 17th St., New York, N. Y.—PA, SS, PRE  
 REMLER CO., LTD., 2101 Bryant St., San Francisco, Calif.—"Remler"—PA, PRE, SS  
 ROTOPHONE CORPORATION, 26 Journal Sq., Jersey City, N. J.—HAC  
 ROWE INDUSTRIES, INC., 3120 Monroe St., Toledo, Ohio—PRE, SS  
 MAURICE SCHWARTZ & SON, 710-712 Broadway, Schenectady, N. Y.—AM, C, K, PA, PRE, SS  
 SEICHELL CARLSON, INC., 2233 University Ave., St. Paul, Minn.—"Seichell Carlson"—PA, SS  
 SILCCO RADIO & TELEVISION CORP., 60 Wall Tower, New York, N. Y.—M, PA, SS  
 MARK SIMPSON DIST. CO., INC., 16 Hudson St., New York, N. Y.—C, K, PA, SS  
 SKAGGS TRANSFORMER CO., 5894 Broadway, Los Angeles, Calif.—C, K, M, PA, PRE, SS  
 S. O. S. CINEMA SUPPLY CORP., 636 11th Ave., New York, N. Y.—AM, PA, PRE, SPA  
 SOUND APPARATUS CO., 150 W. 46th St., New York, N. Y.—C, PA, PRE, SS  
 SPEAK-O-PHONE RECORDING & EQUIPMENT CO., 23 W. 60th St., New York, N. Y.—C, SS  
 \*STANCOR—Standard Transformer Corp.  
 STANDARD TRANSFORMER CORP., 1500 N. Halsted St., Chicago, Ill.—"Stancor"—K  
 STROMBERG-CARLSON TELEPHONE MFG. CO., 100 Carlisle Rd., Rochester, N. Y.—"Stromberg-Carlson"—PA, PRE, SS  
 SUN RADIO CO., 212 Fulton St., New York, N. Y.—AM, C, K, PA, PRE, SS  
 SUNDT ENGINEERING CO., 4757 Ravenswood Ave., Chicago, Ill.—SS  
 TALK-A-PHONE MFG. CO., 1847 S. Millard Ave., Chicago, Ill.—PA  
 TALKING DEVICES CO., 4451 Irving Park Blvd., Chicago, Ill.—PA, PRE  
 TECHNICAL PRODUCTS INTERNATIONAL, 135 Liberty St., New York, N. Y.—"Tinamite"—PA, PRE, SS  
 TELESCO COMPANY, 341 N. Pulaski Rd., Chicago, Ill.—PA, PRE  
 THORDARSON ELECTRIC MFG. CO., 500 W. Huron St., Chicago, Ill.—"Thordarson"—C, K, PA, PRE  
 \*TINAMITE—Technical Products International  
 TRANSFORMER CORP. OF AMERICA, 69 Wooster St., New York, N. Y.—"Clarion"—C, PA, PRE, SS  
 TRIUMPH MFG. CO., 4017 W. Lake St., Chicago, Ill.—PA, PRE, SS  
 UNITED CINEPHONE CORP., United Electronic Industries Div., 43-37 33rd St., Long Island City, N. Y.—PRE, RC, SS  
 UNITED TELEPHONE CORP., 150 Varick St., New York, N. Y.—"UTC"—K  
 UNITED TRANSFORMER CORP., 150 Varick St., New York, N. Y.—K, PA, PRE  
 UNIVERSAL MICROPHONE CO., Inglewood, Calif.—C, PA, PRE, SS  
 \*UTC—United Telephone Corp.  
 VIBRALOC MFG. CO., 1273 Mission St., San Francisco, Calif.—C, PA, SS  
 WEBER MACHINE CORP., 59 Rutter St., Rochester, N. Y.—SPA  
 THE WEBSTER-CHICAGO CORP., 5622 W. Bloomington Ave., Chicago, Ill.—"Webster-Chicago"—C, PA, PRE, SS  
 WEBSTER ELECTRIC CO., Racine, Wis.—"Webster-Electric"—PA, PRE, SS  
 WESTERN ELECTRIC CO., 300 Central Ave., Kearny, N. J.—M, PA, PRE, SS  
 WESTERN SOUND & ELEC. LABS., INC., 311 W. Kilbourn Ave., Milwaukee, Wis.—PA, PRE, SS



Get This Electric Dry Shaver

**ABSOLUTELY FREE!**

JUST THINK OF IT—you can get absolutely FREE, the useful DRY ELECTRIC SHAVER which is shown at the left. This ELECTRIC DRY SHAVER is sent to you by the publishers with a one-year subscription to RADIO-CRAFT.

Here Are the Features of The ELECTRIC DRY SHAVER

Constructed of metal with attractive red bronze finish. Scientifically constructed to give a perfectly clean shave. 5-foot rubber insulated cord and plug. Constructed to last for many years.

Operates from 110-volt, 60-cycle A.C. electric line. Carries a two-year manufacturer's guarantee. A fine quality, self-sharpening toilet necessity.

Send your subscription to RADIO-CRAFT for One Year (12 issues) and receive absolutely FREE one of these remarkable Electric Dry Shavers. New subscribers are accepted or you may extend your present subscription another twelve months. Mail your remittance of \$2.00 (plus 25c for shipping charges on Shaver) to the publishers. (Canada and foreign \$2.75.) You will receive your DRY ELECTRIC SHAVER immediately by return mail. Use coupon below to enter your subscription.

**RADIO-CRAFT**

20 Vesey Street, New York, N. Y.

RADIO-CRAFT, 20 Vesey Street, New York, N. Y.

Gentlemen: Enclosed find my remittance of \$2.00 for which enter my subscription to RADIO-CRAFT for one year (12 issues). Send me immediately FREE ELECTRIC DRY SHAVER (Canada and foreign \$2.75). In U. S. add only 25c additional to cover shipping charges on Shaver.

New Subscriber  Extend Present Subscription

Name .....

Address .....

City ..... State .....

(Send remittance by check, money order or unused U.S. Postage Stamps. Register letter if you send cash or stamps.) RC-141

OPERATES ON 110-VOLT, 60-CYCLE A.C. LINE

WE SHIP ELECTRIC DRY SHAVER THE SAME DAY YOUR SUBSCRIPTION ORDER IS RECEIVED.

CLIP COUPON— AND MAIL!

**ADDENDA**

AMERICAN PHENOLIC CORP., 1250 Van Buren St., Chicago, Ill.—"Amphenol"—C, GC, G, P, SKT, T, WF, CD

Add SKT (sockets), as above, to listing in Section II, November Radio-Craft, under Hardware—Connectors and Misc. Parts.

NATIONAL UNION RADIO CORP., 57 State St., Newark, N. J.—C, CC, ED, EW, I, MR, MP, PR, T, TC, PFC

Add all listings as above in Section I, October RADIO-CRAFT, under Condensers, Fixed.



**BURGLAR ALARM**

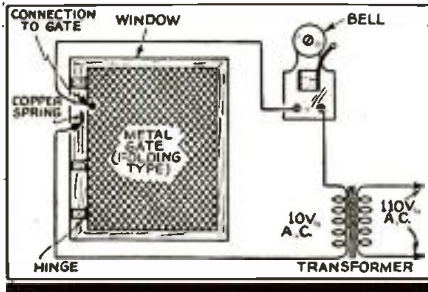

● RECENTLY I devised a burglar alarm that worked as perfectly as one costing 10 to 15 times as much. The diagram of this alarm is reproduced here.

All the materials required for the alarm: an old bell-ringing transformer, an ordinary door-bell, a piece of spring steel or spring copper, preferably copper, some rubber covered wire for connecting up the circuit, a few wood-screws.

The transformer and bell are mounted near the window or door as the case may be. I mounted both near the window, the window in this case being one of the metal swinging types, the piece of spring copper was mounted on the side of the window right behind the folding iron gate so that when the gate is pushed back it touches the copper and completes the circuit and the bell rings. The gate is used as one pole of the switch and the copper as the other pole.

I installed two of these so far and I now have an order for another one.

Through installing these I've had 5 "radios" to repair. I'm now seriously thinking of advertising for burglar alarm work as a sideline to my regular radio repair.

It takes but a few minutes to install, and it costs so little that the average customer will be more than pleased with it.

HAROLD R. KUNTZ.

**CLOTHESPINS AT YOUR SERVICE!**

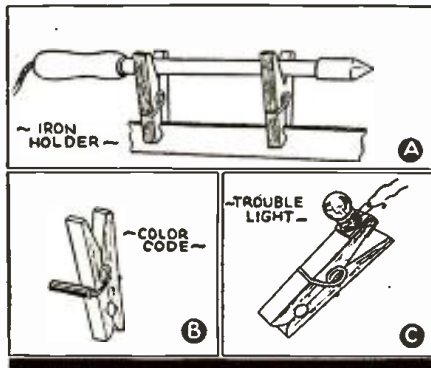

● A VERY useful and inexpensive item in my shop is the ordinary spring-type clothespin. Here are a few of its many uses.

As a soldering iron holder (A).—Clip 2 of them onto the chassis of the set you are repairing. They support the iron firmly with less loss of heat than other stands, and without danger of being knocked off.

They may be color coded (B).—Merely slip 1/2-in. pieces of spaghetti over the ends of the spring which holds them together. Clipped onto the ends of wires, etc., they serve as identification marks.

Tinning, etc.—Small washers, screws, etc., clipped in one will not get lost, and may be tinned without loss of heat. To prevent scorching or burning insulation on adjacent wiring when soldering hard to get

at places, clip one over the wires it is desired to protect.

Trouble light (C).—A standard dial lamp socket (C) fits nicely over one end to form a convenient trouble light as leads can be taken from filament or pilot terminals.

If you smoke, one will hold a cigarette; two a pipe. This is a general idea of the many uses to which these may be put. In use many more will suggest themselves.

VINCENT J. LEWIS, JR.,  
Yonkers, N. Y.

**SIMPLE RESONANCE INDICATOR**

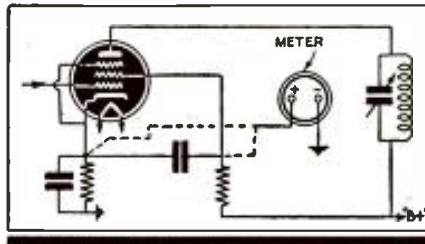

● HERE is an idea I have often used in aligning the trimming condensers of a radio set.

When it is necessary to adjust the trimmer condensers of a radio receiver that has automatic volume-control, a voltmeter can be used as a resonance indicator by simply connecting it to register the grid bias or screen-grid voltage of the tubes, upon which the automatic volume control operates, in the usual manner of testing these voltages.

When a signal is coming through, and the A.V.C. begins to function, the negative grid voltage on the R.F. tubes is increased which causes a variation in both the grid bias and the screen-grid voltages.

The grid bias voltage will decrease and the screen-grid voltage will increase. The stronger the signal strength is the greater this change will be.

The tuning dial should be tuned to the signal so that the meter reading goes through its maximum change. Then the trimmer condensers should be adjusted to give the highest possible reading on the meter if it is connected to the screen-grid; or the lowest reading if the meter is connected to the cathode.

Due to the fact that the operating voltages vary in different receivers, and also the resistance and load of the voltage dividers may vary widely, this system will not give the same results on different radio sets, but it is accurate and fast, and in the majority of cases it has been quite handy. The positive meter lead will be connected either to cathode or screen-grid terminal of the "A.V.C.-ed" tube.

R. V. CARPENTER,  
Carpenter Radio Service,  
Rewey, Wis.

**EMERGENCY FLUX**

● BOYS, when you are sorely in need of a soldering flux—no resin core, nor Korrode, just visit your wife's or your mother's medicine closet and borrow a bottle of Amos & Andy's famous "gargle", in other words Pepsodent. I have used this dope on stainless steel and done a good job too.

H. C. HARRIS,  
Delta, Colo.

**IF UNCLE SAM WANTS YOU . . .**

. . . How will you know what branch of the Service is best adapted to your radio abilities? Read "Military Radio," in February *Radio-Craft*. for all the answers.



Complete Selections . . . Guaranteed Quality

**Replacement Parts**

Everything you need in exact duplicate or universal replacement or repair parts. Tubes, condensers, resistors, transformers, hardware, tools, etc. Leading brands.

**Latest Radio Sets**

A model for every purse and purpose. Auto Sets, Midgets, Battery Portables, Table Models, Consoles, Photo-Radio and recorder combinations—for operation on AC or DC.

**Public Address Equipment**

A complete line of amplifiers, microphones, baffles, recording equipment and accessories for every type of installation—permanent, portable and mobile, from 5 to 100 watts.

**Newest Electric Appliances**

Extra profits for you! Standard Brand Electric Irons, Grills, Toasters, Percolators, Waffle Irons, Vacuum Cleaners, Perches, Mixers and many others, all at lowest prices.

**YOU SAVE MONEY AT RADOLEK**

**MAIL THIS COUPON TODAY**

The RADOLEK CO.  
601 W. Randolph St., Chicago, Dept. C-49  
Send the New 1941 Radio Profit Guide FREE.

Name..... Dealer?  
Address.....  
Experimenter?..... Serviceman?..... Amateur?.....

**300 WAYS TO MAKE MONEY NOW 10c Per Copy**

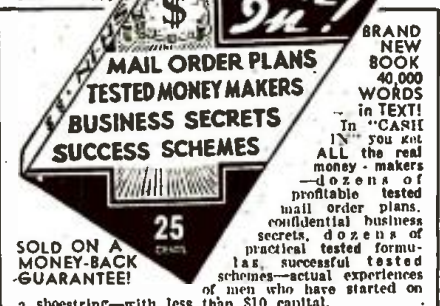

BRAND NEW BOOK 40,000 WORDS in TEXT! In "CASH IN" you not only get ALL the real money-makers—dozens of profitable tested mail order plans, confidential business secrets, dozens of practical tested formulas, successful tested schemes—actual experiences of men who have started on a shoestring—with less than \$10 capital.

Buyers of This Book Tell Us—  
"Biggest value I've yet to see. Book is worth at least a dollar." N. Bush, Elms, N. Y.  
"Your book is as good if not better than others selling at \$1.00." George Brunet, Montreal, Can.  
"CASH IN is the best value I have yet to see in the mail order field." Lawrence Fox, Brooklyn, N. Y.  
"CASH IN" contains only tested ideas covering every type of full- or spare-time enterprise—it's a "masterpiece" in business ventures.

10c a copy postpaid. Send U.S. stamps or coin.

**NATIONAL PLANS INSTITUTE**  
246-R Fifth Ave., N.Y.C.

**WILL BUY FOR CASH**

**OLD POSTAGE STAMPS AND COMPLETE COLLECTIONS**

Thousands of dollars lying idle in old postage stamps and collections! Dip yours out and sell at today's top prices. Especially interested in old United States stamps (used or unused) and later issues up to 1930. Write for references, or send stamps for prompt appraisal and offer.

**HARRY P. BRIDGE**  
1324 Walnut St. Philadelphia, Pa.

**GEOPHYSICAL PROSPECTING OUTFITS**



**BLUE PRINTS and INSTRUCTIONS**

For Building the Following Treasure Finders and Prospecting Outfits

- Folder No. 1. The "Radioflector Pilot"—consists of a 2-tube transmitter and 3-tube receiver. Principle: radiated Wave from transmitter loop is reflected back to receiver loop. Emits visual and aural signals. Tubes used: two 1A5G—two 1N5G—one 1H5G.
- Folder No. 2. The "Harmonic Frequency Locator"—Transmitter radiates low frequency wave to receiver, tuned to one of Harmonics of transmitter. Using regenerative circuit. Emits aural signals. Tubes used: one 1G6G—one 1N5G.
- Folder No. 3. The "Beat-Note Indicator"—Two oscillators so adjusted as to produce beat-note. Emits visual and aural signals. Tubes used: Three type '30.
- Folder No. 4. The "Radio-Balance Surveyor"—a modulated transmitter and very sensitive loop receiver. Principle: Balanced loop. Emits visual and aural signals. By triangulation depth of objects in ground can be established. Tubes used: Seven type '30.
- Folder No. 5. The "Variable Inductance Monitor"—a single tube oscillator generating fixed modulated signals and receiver employing two stages R.F. amplification. Works on the inductance principle. Emits aural signals. Tubes used: six type '30.
- Folder No. 6. The "Hughes Inductance-Balance Explorer"—a single tube Hartley oscillator transmitter and sensitive 3-tube receiver. Principle: Wheatstone bridge. Emits aural signals. Tubes used: two type '30—one type '32—one type '33.
- Folder No. 7. The "Radiodyne Prospector"—a completely shielded instrument. Principle: Balanced loop. Transmitter, receiver and batteries enclosed in steel box. Very large field of radiation and depth of penetration. Emits aural signals. Tubes used: two 1N5G—one 1G4G—one 1H5G—one 1Q5—one 1G4.

With any one of the modern geophysical methods described in the Blue-Print patterns. Radio outfits and instruments can be constructed to locate metal and ore deposits (prospecting); finding lost or buried treasures; metal war relics; sea and land mines and "duds"; mineral deposits; subterranean water veins; oil deposits (under certain circumstances); buried gas and water pipes; tools or other metallic objects sunken in water, etc., etc.

Each set of blueprints and instructions enclosed in heavy envelope (9 1/2" x 12 1/2"). Blueprints 22" x 34"; eight-page illustrated 8 1/2" x 11" folder or of instructions and construction data. **50¢** Add 5¢ for postage

The complete set of seven folders..... **\$3.00**  
Shipping weight 2 lbs. (Add 25¢ for shipping anywhere in U.S.A.)

**TECHNIFAX**

RC-141 1917 S. STATE ST. CHICAGO, ILL.

**TECHNIFAX** 1917 So. State, Chicago, Ill.

Enclosed herewith \$..... for which mail to address below:

Treasure Finder No. 1, 2, 3, 4, 5, 6, 7.  
Complete set of seven folders.

NAME .....

ADDRESS .....

CITY ..... STATE .....

RC-141

**BOOK REVIEWS**

**THE FUNDAMENTALS OF ELECTROMAGNETISM**, by E. G. Cullwick (1939). Published by Cambridge University Press. Size, 5 1/2 x 8 3/4 ins., cloth cover, 145 illustrations, 352 pgs. Price, \$3.75.

Here is a restatement for engineering students and others, of the physical and theoretical principles in modern scientific thought, by the professor and head of the Department of Electrical Engineering in the University of Alberta, Canada. The book includes numerous examples based on the recently-adopted M.K.S. system of practical units.

In his prologue the author calls attention to the fact that the fundamental physical phenomena of electricity and magnetism are common to all operations in the field of electrical energy, and hence, a coherent and unified basic system is essential if the engineer is to thoroughly understand the operation of a broadcast program, a cathode-ray-tube waveform, or even the operation of a toy magnet.

The book will be of greatest benefit to technicians and students who are familiar with advanced algebra and trigonometry.

Chapter headings follow: The Electrostatic Field and the Electric Current; The Magnetic Field and Electromagnetic Induction; The Magnetic Field of the Electric Current; Ferromagnetism; Electromagnetic Waves; The Vector Potential of the Electric Current, and Its Uses.

**THE ART OF MODERN WARFARE**, by Herman Foertsch, (Col. of the German General Staff) with introduction by Major Geo. S. Elliott. Size 6"x8 3/4", 274 pages, published by Veritas Press, New York.

This book, written as it is by an outstanding expert on military matters, should be "must" reading for every student of the science of war. Those interested in radio and wire communication as applied to modern military maneuvers, will find some very interesting reading in this excellent work. In several places Col. Foertsch discusses the values of radio and also wire connection, the methods of catching and interpreting enemy messages, the rôle of the engineer in war, the importance of radio propaganda, etc.

**RADIO OPERATORS' LICENSE GUIDE**, by Wayne Miller (1940), 2nd Edition. Published by Wayne Miller, Consulting Communications Engineer. Size 6x9 ins., paper cover, 158 pgs. Price \$3.00.

It is frequently possible to obtain an insight into the worth of a publication by noting its author. In this instance, we learn that Mr. Miller has been "through the mill," and therefore, in "License Guide" presents the results of his practical experience as Chief Engineer of broadcast stations, Chief Instructor of radio schools, Radio Operator at broadcast and communications stations, Television Research Engineer, Test Technician with one of the largest radio manufacturers, and Design Engineer for another large radio corporation.

"License Guide" contains over 1,250 acceptable answers to the new "6-Element" radio operator license examination questions as embodied in the Federal Communications Commission Study Guide.

The contents of this book is divided as follows: Element 1: Questions and Answers on Basic Law; Element 2: Questions and Answers on Basic Theory and Practice; Element 3: Questions and Answers on Radiotelephony; Element 4: Questions and Answers on Advanced Radiotelephony; Element 5: Questions and Answers on Radiotelegraphy; Element 6: Questions and Answers on Advanced Radiotelegraphy.

The following appendices close the book: United States Radio Inspection Districts, Federal Communication Commission Rules and Regulations governing Commercial Radio Operators, Abbreviations to be used in Radio Communications (Q code), Miscellaneous abbreviations to be used in Radio Communication, International Morse Code with extracts from the list of punctuations and other signs contained in the Telegraph Regulations of the Cairo Conference of 1938.

*Index to advertisers*

**BROADCASTING**

Radio Corporation of America  
Inside Front Cover

**PUBLIC ADDRESS EQUIPMENT**

Amplifier Co. of America.....	429
John Meek Industries.....	427
Miles Reproducer Co.....	429
Music Master Mfg. Co.....	413
The Turner Company.....	429
Regal Amplifier Mfg. Co.....	427
Universal Microphone Co., Ltd.....	429
University Laboratories.....	429
Wright-DeCoster, Inc.....	422

**PUBLISHERS**

Data Print Co.....	429
Funk & Wagnalls Co.....	388
Miller, Wayne.....	389
National Plans Inst.....	447
Radecraft Publications, Inc.....	390, 422
Radio & Technical Pub. Co.....	388, 389
Radio Publications.....	438
Supreme Publications.....	406
Technifax.....	437, 448

**RADIO PARTS**

Amperite Co.....	406
Dumont Electric Co., Inc.....	413
Hammarlund Mfr. Co.....	406
International Resistance Co.....	399
National Union Radio Corp.....	Back Cover
Ohmite Mfg. Company.....	413
Solar Mfg. Corp.....	408

**RADIO SETS**

Goldentone Radio Co.....	437
Henry Radio Shop.....	431
Howard Radio Co.....	417
Meissner Mfg. Company.....	387
Midwest Radio Corp.....	425

**RADIO SUPPLY HOUSES**

Allied Radio Corp.....	433
Burstein-Applebee Co.....	408
Lafayette Radio Corp.....	437
Radolek Co.....	447
Sears, Roebuck & Company.....	401

**SCHOOLS**

Capitol Radio Eng. Inst.....	388
Lincoln Engineering School.....	389
National Radio Institute.....	385
National Schools.....	388
New York Y.M.C.A. Schools.....	389
Radio Training Assoc.....	389
RCA Institutes.....	388
Sprayberry Academy of Radio	

Inside Back Cover

**TEST EQUIPMENT**

Radio City Products Co.....	406
Readrite Meter Works.....	408
Superior Instruments Co.....	413, 419, 421, 423
Supreme Instruments Corp.....	411
Triplett Electrical Instrument Co.....	405

**TUBES**

Hygrade Sylvania Corp.....	404
----------------------------	-----

**MISCELLANEOUS**

Atlas Press Co.....	416
Bridge, Harry P.....	447
Classified Section.....	416
Flight Magazine.....	423
Lancaster, Allwine & Rommel.....	423
Paramount Products Co.....	416
Rosicrucians, The.....	423
Wellworth Trading Co.....	429
Woodstock Typewriter Co.....	408

(While every precaution is taken to insure accuracy, we cannot guarantee against the possibility of an occasional change or omission in the preparation of this index.)



# FULL EQUIPMENT

# *Included* WITH SPRAYBERRY RADIO TRAINING

**Experience Easily  
Acquired at Home!**

**Over 100 Experiments Plus Many Other Special Features  
... ALL DESIGNED TO HELP YOU MAKE FAST PROGRESS!**

SPRAYBERRY Training starts right at the beginning of Radio . . . unfolds each subject in a simplified, logical, understandable style. You easily learn Television, Frequency Modulation, Signal Tracing, Mobile Radio (Auto-Tank), Aviation Radio, Electronics, Facsimile Radio, Radio Set Repair and Installation Work. You learn quickly in your spare hours . . . AT HOME OR AT CAMP.

**Training Prepares You for a Business of Your Own . . .  
Or Good Radio Jobs at Excellent Pay!**

The great, fascinating and progressive field of Radio and Television offers many opportunities to the man who wants to get ahead. There is good money to be made. My Training is designed to give you quick access to these opportunities. SPRAYBERRY Methods are thorough and practical. Your Training will not interfere with your present work.

**You Get Professional Test Equipment  
Plus Experimental Outfits!**

Includes 146 RADIO PARTS for building a complete Receiver, RADIO TOOLS and a modern TESTER-ANALYZER. You also receive 8 BIG SHIPMENTS OF RADIO EQUIPMENT for conducting actual experiments with your own hands. I show you how to create Radio defects . . . how to correct them.

**All Equipm  
Becom  
You  
Perso  
Prope**

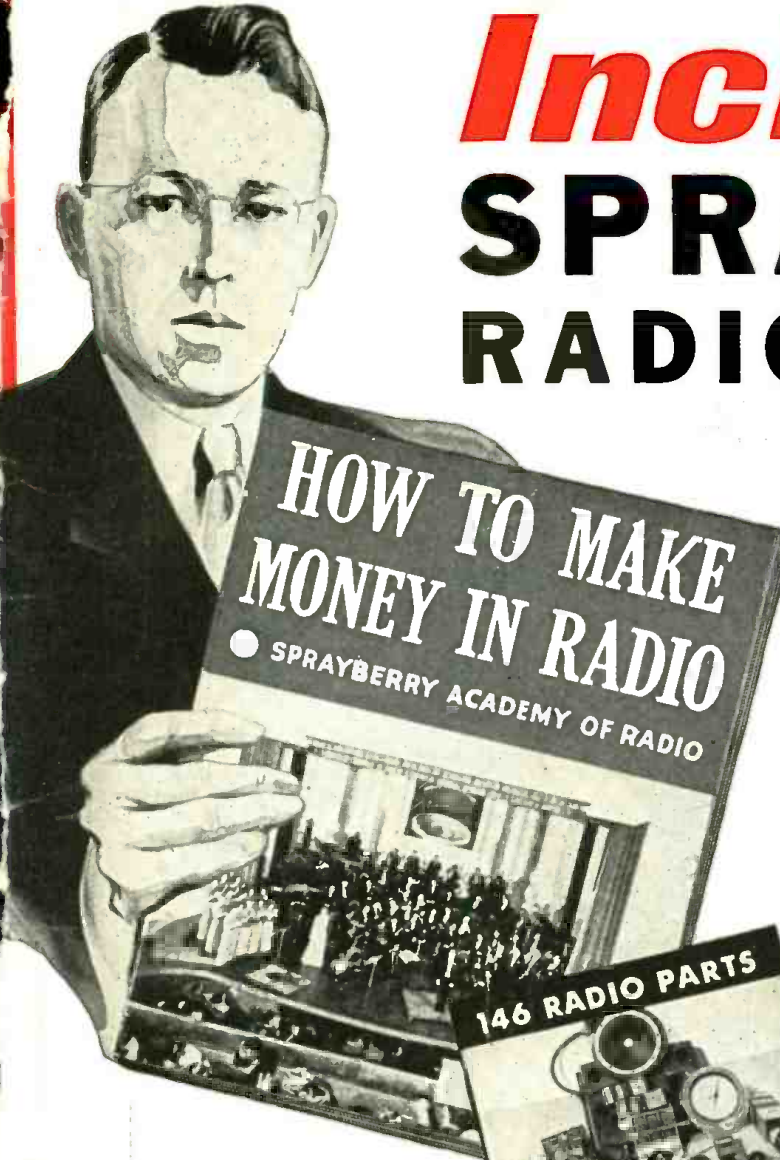

**READ WHAT THESE FELLOWS  
SAY ABOUT THE NEW  
PRACTICAL SPRAYBERRY  
TRAINING**

**EARNED \$250 SINCE STARTING**



"I have only completed one-third of the Sprayberry Course and I find it very interesting, which makes it easy to learn. "By devoting several hours of my spare time daily to studying and servicing, I have made about \$250 gross since starting the Course." Earl W. Hostetter, R. No. 4, Lebanon, Pa.

**"SO MUCH FOR SO LITTLE"**

"Now just a few words about your Course—the more I get from it, the more I wonder how you can give so much for so little.

"I believe it to be the finest of its kind obtainable, and I would urge anyone wishing to study Radio seriously to take your Course." George W. Elliott, 521 Elwyn St., Nelson, B. C., Canada.



**"MADE OVER \$300 NET IN SIX MONTHS"**

"While I have not hung out my 'shingle' yet, I have made over \$300 net in the last six months, doing some full and some part time Radio servicing. "I am completely satisfied in every way with your Course, and I am mighty glad I signed on the 'dotted line,' making me a student of the Sprayberry Academy of Radio." Wendell M. Caldwell, 93 Hickory St., Rochester, N. Y.



**Cash In on Radio's Rich Opportunities**

No matter if you desire to BE YOUR OWN BOSS in your own business or hold down a good job in Radio, my Training will give you the useful information and knowledge to win success. Days of delay mean precious time wasted. Start training for a money-making Radio career—right now.

**REMEMBER —THE SPRAYBERRY COURSE IS SOLD  
UNDER A MONEY-BACK AGREEMENT**



**No Previous  
Experience Needed**

It makes no difference what your education has been. I can fit you quickly for a good-paying Radio job. I make it easy for you to grasp Radio principles and remember them. Your success is my full responsibility.

**EARN WHILE YOU LEARN**

My BUSINESS BUILDERS show you how to put your equipment to actual use in handling money-making Radio Service Jobs shortly after you begin Training.

**Learn More About the  
SPRAYBERRY Method  
And How Easy It Is to Start**

The complete details of my fundamental Course and Advanced Training Course . . . all features are fully described in my new, valuable 32-page FREE book. Send for your copy. No obligation.

**DON'T DELAY! ACT NOW**

**SPRAYBERRY ACADEMY OF RADIO**

**F. L. Sprayberry, Pres.  
420-A. University Place, N. W.  
Washington, D. C.**

Please send my FREE copy of "HOW TO MAKE MONEY IN RADIO"

Name . . . . . Age . . . . .

Address . . . . .

City . . . . . State . . . . .

Tear off this coupon, mail in envelope or paste on penny postcard.

**RUSH THIS COUPON for BIG FREE BOOK**  
... GIVING COMPLETE FACTS



# Be Sure To Get These N.U. Condenser Specials!

**\$7.50**



**PACKED IN ONE CONTAINER**

**TWO DRAWER STEEL CABINET**

Here's a honey of a steel utility cabinet with the drawers partitioned to make it easy for storing small parts. You'll find this cabinet a mighty useful addition to your shop equipment and best of all . . . you get it **FREE** on this limited offer. Don't delay, take advantage of this deal and get your **FREE** steel cabinet. Cabinet size is — length 11½", width, 9½", depth, 5".

**NO DEPOSIT ON CABINET**

You can buy the condenser assortment for \$7.50 plus a 30 N.U. point contract. Points can be added to present N.U. contract. You get the steel cabinet **FREE** now. There is no deposit. (The condenser assortment comes to you packed with the cabinet.)

*Popular*

**CONDENSER ASSORTMENT**

**LIST**

**\$14.35** ★

This fine assortment of popular type N.U. condensers will move fast, give you a good profit and insure the good will of your customers. If you already using N.U. condensers, you'll be sure to snap up this offer in a hurry. If you don't know yet how really good N.U. condensers are, here's a great opportunity to try them! The assortment you get on this limited offer consists of:

- |          |          |
|----------|----------|
| 3—JB8450 | 1—AT2015 |
| 1—JB8845 | 1—AT8250 |
| 1—SC8450 | 1—AT4450 |
| 1—AT815D | 3—AT8450 |
| 1—AT1615 | 1—AT1645 |
| 3—T601   |          |
| 4—T602   |          |
| 3—T605   |          |
| 5—T610   |          |
| 2—T625   |          |



**GET THIS**

**NEW WALSCO STAPLER**

**\$7.00**

\$5.00 For Condensers  
\$2.00 as Deposit

**EVERY RADIO SERVICE MAN NEEDS IT . . .**

New automatic stapler for quick and easy installation of lead-ins—indoor antennae — running leads and power cords, P.A. installations and other shop use. Usual dealer price \$3.30.

**CONTENTS —**

**KIT CONTAINS:**

**1 WALSCO STAPLER**

TYPE	QUANTITY
JB 8450	1
SC 8450	1
AT 8150	1
1615	1
8250	1
4450	1
8450	2
1645	1
AT 1125	1
8845	1
T 601	2
602	2
605	2
610	3
625	1

List Value of N.U. Condensers in Kit, \$10.00. Dealer Price Walsco Stapler, \$3.30 (Packed Together) **YOURS FOR ONLY \$7.00**

**YOURS FREE ON THIS N. U. CONDENSER DEAL**

DEALER PAYS \$5.00 FOR CONDENSERS, THE ADDITIONAL \$2.00 IS REBATED WHEN DEAL REQUIREMENT IS COMPLETED.

**HOW YOU GET IT**

Just order from your N.U. distributor. Your total payment is \$7.00. You sign an agreement for 75 points and deposit is refunded when the 75 purchase points are completed. Points can be used on N.U. Tubes, Sound X/Tra Tubes, N.U. Radio Batteries or N.U. Condensers. The National Union Program on free equipment has helped thousands of dealers to own the "finest radio shop in town".

**POINTS ARE COUNTED AS FOLLOWS:**

1 Tube = 1 Point. 1 Electro Condenser = 1 Point. 10 Paper Condensers = 1 Point. 2 Numite Condensers = 1 Point. 1 Radio Battery = 1 Point.

© 1940 N.U.R. Corp.

*See Your Jobber or Write*

**NATIONAL UNION RADIO**

57 STATE STREET, NEWARK, N. J.

*Corporation*



# ADV Plans, LLC

## Copyright Notice:

The entire contents of this CD/DVD are copyright 2014 by ADV Plans, LLC. All Rights Reserved.

Reproduction or distribution of this disk, either free or for a fee is strictly prohibited. We actively monitor and remove listings on eBay thru Vero.

You are free to copy or use individual images in your own projects, magazines, brochures or other school projects.

Only the sellers listed here are authorized distributors of this collection:  
[www.theclassicarchives.com/authorizedsuppliers](http://www.theclassicarchives.com/authorizedsuppliers)

Please view our other products at  
[www.theclassicarchives.com](http://www.theclassicarchives.com),  
or our ebay stores:

[TheClassicArchives](#)  
[ADVPlans](#)  
[SuperShedPlans](#)

